

**WSR 05-23-029**  
**PROPOSED RULES**  
**DEPARTMENT OF**  
**SOCIAL AND HEALTH SERVICES**  
 (Aging and Disability Services Administration)  
 [Filed November 8, 2005, 1:22 p.m.]

Original Notice.

Preproposal statement of inquiry was filed as WSR 05-16-079.

Title of Rule and Other Identifying Information: The department is adding new and amending sections within chapter 388-106 WAC, Long term care services; amending and repealing sections within chapter 388-71 WAC, Home and community services and programs; and amending sections within chapter 388-110 WAC, Contracted residential care services.

Hearing Location(s): Blake Office Park East, Rose Room, 4500 10th Avenue S.E., Lacey, WA 98503 (one block north of the intersection of Pacific Avenue S.E. and Alhadeff Lane, behind Goodyear Tire. A map or directions are available at <http://www1.dshs.wa.gov/msa/rpau/docket.html> or by calling (360) 664-6097, on January 10, 2006, at 10:00 a.m.

Date of Intended Adoption: Not earlier than January 11, 2006.

Submit Written Comments to: DSHS Rules Coordinator, P.O. Box 45850, Olympia, WA 98504, delivery 4500 10th Avenue S.E., Lacey, WA 98503, e-mail [fernaax@dshs.wa.gov](mailto:fernaax@dshs.wa.gov), fax (360) 664-6185, by 5:00 p.m. January 10, 2006.

Assistance for Persons with Disabilities: Contact Stephanie Schiller, DSHS Rules Consultant, by January 6, 2006, TTY (360) 664-6178 or (360) 664-6097 or by e-mail at [schilse@dshs.wa.gov](mailto:schilse@dshs.wa.gov).

Purpose of the Proposal and Its Anticipated Effects, Including Any Changes in Existing Rules:

**Summary of Significant WAC Changes**

**Chapter 388-106 WAC Changes**

<b>Affected WAC</b>	<b>Change</b>
388-106-0010	Changed the following definitions: <ul style="list-style-type: none"> <li>• Ability to make self understood</li> <li>• Activities of daily living, bed mobility</li> <li>• Assistance available</li> <li>• Assistance with medication management</li> <li>• Categorically needy</li> <li>• Decision making</li> <li>• Estate recovery</li> <li>• Informal support</li> <li>• Institution</li> <li>• Self performance for ADLs</li> <li>• Self performance for IADLs</li> <li>• SSI-related</li> <li>• Support provided</li> </ul>

<b>Affected WAC</b>	<b>Change</b>
388-106-0015	Updated WAC reference.
388-106-0035	Clarified language on whether services are covered when client is out of state.
388-106-0050	Clarified when assessments occur and when an in-person assessment is not required.
388-106-0065	Removed examples of who can be present during an assessment.
388-106-0130	Added information about deduction for meal preparation, ordinary housework, and essential shopping. Included private duty nursing as a service that personal care hours can be used for.
388-106-0213	Updated age guidelines for children receiving MPC.
388-106-0215 (new)	Included WAC on when MPC services start.
388-106-0200, 388-106-0300, 388-106-0305, 388-106-0400, and 388-106-0500	Included criteria for how nursing services are authorized.
388-106-0705 and 388-106-0715	Removed the provisions to deem eligibility. Clarified eligibility language regarding prepaid benefits.
388-106-1303 (new)	Proposed new rules on client responsibilities.
388-71-0540, 388-71-0546, 388-71-0551, 388-71-0556, and 388-71-05695	Included references to managed care entities, who will also be responsible for ensuring that individual providers are qualified and trained.
388-71-0704	Included language on what services the adult day care center must provide onsite.
388-71-0706	Included language on what services the adult day health center must provide onsite.
388-71-0210 through 388-71-0260	Repeal.

**Chapter 388-100 WAC Changes**

388-110-020	Updated definitions to include links to new chapter 388-106 WAC.
388-110-100	Revised the maximum number of days required for approval of social leave to eighteen days per calendar year and clarified language regarding Medicaid resident.

**Affected WAC**      **Change**  
 388-110-220      Updated definitions to include links to new chapter 388-106 WAC. Added dementia training topics. Changed definition of eating.

Reasons Supporting Proposal: See Purpose above.  
 Statutory Authority for Adoption: RCW 74.08.090, 74.09.520, 74.39A.010, and 74.39A.020.  
 Statute Being Implemented: Chapters 74.09, 74.39, and 74.39A RCW.  
 Rule is not necessitated by federal law, federal or state court decision.  
 Name of Proponent: Department of Social and Health Services, governmental.  
 Name of Agency Personnel Responsible for Drafting, Implementation and Enforcement: Brooke Buckingham, P.O. Box 45600, Olympia, WA 98504, (360) 725-3213.  
 No small business economic impact statement has been prepared under chapter 19.85 RCW. The department has analyzed these rules and determined that no new costs will be imposed on small businesses.  
 A cost-benefit analysis is required under RCW 34.05.328. A preliminary cost-benefit analysis may be obtained by contacting Brooke Buckingham, P.O. Box 45600, Olympia, WA 98504, phone (360) 725-3213, fax (360) 438-8633, e-mail buckibe@dshs.wa.gov.  
 November 4, 2005  
 Andy Fernando, Manager  
 Rules and Policies Assistance Unit

AMENDATORY SECTION (Amending WSR 05-11-082, filed 5/17/05, effective 6/17/05)

**WAC 388-71-0540 When will the department ((☞)), AAA, or managed care entity deny payment for services of an individual provider or home care agency provider?** The department ((☞)), AAA, or managed care entity will deny payment for the services of an individual provider or home care agency provider who:

- (1) Is the client's spouse, per 42 C.F.R. 441.360(g), except in the case of an individual provider for a chore services client. Note: For chore spousal providers, the department pays a rate not to exceed the amount of a one-person standard for a continuing general assistance grant, per WAC 388-478-0030;
- (2) Is the natural/step/adoptive parent of a minor client aged seventeen or younger receiving services under Medicaid personal care;
- (3) Has been convicted of a disqualifying crime, under RCW 43.43.830 and 43.43.842 or of a crime relating to drugs as defined in RCW 43.43.830;
- (4) Has abused, neglected, abandoned, or exploited a minor or vulnerable adult, as defined in chapter 74.34 RCW;
- (5) Has had a license, certification, or a contract for the care of children or vulnerable adults denied, suspended, revoked, or terminated for noncompliance with state and/or federal regulations;

(6) Does not successfully complete the training requirements within the time limits required in WAC 388-71-05665 through 388-71-05865;

(7) Is already meeting the client's needs on an informal basis, and the client's assessment or reassessment does not identify any unmet need; and/or

(8) Is terminated by the client (in the case of an individual provider) or by the home care agency (in the case of an agency provider).

(9) In addition, the department ((☞)), AAA, or managed care entity may deny payment to or terminate the contract of an individual provider as provided under WAC 388-71-0546, 388-71-0551, and 388-71-0556.

AMENDATORY SECTION (Amending WSR 01-11-019, filed 5/4/01, effective 6/4/01)

**WAC 388-71-0546 When can the department ((☞)), AAA, or managed care entity reject the client's choice of an individual provider?** The department ((☞)), AAA, or managed care entity may reject a client's request to have a family member or other person serve as his or her individual provider if the case manager has a reasonable, good faith belief that the person will be unable to appropriately meet the client's needs. Examples of circumstances indicating an inability to meet the client's needs could include, without limitation:

- (1) Evidence of alcohol or drug abuse;
- (2) A reported history of domestic violence, no-contact orders, or criminal conduct (whether or not the conduct is disqualifying under RCW 43.43.830 and 43.43.842);
- (3) A report from the client's health care provider or other knowledgeable person that the requested provider lacks the ability or willingness to provide adequate care;
- (4) Other employment or responsibilities that prevent or interfere with the provision of required services;
- (5) Excessive commuting distance that would make it impractical to provide services as they are needed and outlined in the client's service plan.

AMENDATORY SECTION (Amending WSR 01-11-019, filed 5/4/01, effective 6/4/01)

**WAC 388-71-0551 When can the department ((☞)), AAA, or managed care entity terminate or summarily suspend an individual provider's contract?** The department ((☞)), AAA, or managed care entity may take action to terminate an individual provider's contract if the provider's inadequate performance or inability to deliver quality care is jeopardizing the client's health, safety, or well-being. The department ((☞)), AAA, or managed care entity may summarily suspend the contract pending a hearing based on a reasonable, good faith belief that the client's health, safety, or well-being is in imminent jeopardy. Examples of circumstances indicating jeopardy to the client could include, without limitation:

- (1) Domestic violence or abuse, neglect, abandonment, or exploitation of a minor or vulnerable adult;
- (2) Using or being under the influence of alcohol or illegal drugs during working hours;

(3) Other behavior directed toward the client or other persons involved in the client's life that places the client at risk of harm;

(4) A report from the client's health care provider that the client's health is negatively affected by inadequate care;

(5) A complaint from the client or client's representative that the client is not receiving adequate care;

(6) The absence of essential interventions identified in the service plan, such as medications or medical supplies; and/or

(7) Failure to respond appropriately to emergencies.

AMENDATORY SECTION (Amending WSR 01-11-019, filed 5/4/01, effective 6/4/01)

**WAC 388-71-0556 When can the department ((☞)), AAA, or managed care entity otherwise terminate an individual provider's contract?** The department ((☞)), AAA, or managed care entity may otherwise terminate the individual provider's contract for default or convenience in accordance with the terms of the contract and to the extent that those terms are not inconsistent with these rules.

AMENDATORY SECTION (Amending WSR 04-02-001, filed 12/24/03, effective 1/24/04)

**WAC 388-71-05695 Who is required to complete orientation, and when must it be completed?** (1) Home care agency providers must complete orientation before working with the agency's clients. Orientation must be provided by appropriate agency staff.

(2) Individual providers must complete orientation provided by DSHS ((☞)), the area agency on aging (AAA), or managed care entity no later than fourteen calendar days after beginning to work with their first DSHS client. Individual providers who live and are providing care at a great distance from the DSHS or AAA office may be oriented by distance learning, with phone contact by the person overseeing the orientation to answer questions.

(3) Parents who are individual providers for their adult children are exempt from the orientation requirement.

AMENDATORY SECTION (Amending WSR 05-11-082, filed 5/17/05, effective 6/17/05)

**WAC 388-71-0704 Adult day care—Services.** Adult day care is a supervised daytime program providing core services as defined in WAC 388-106-0800. Core services are appropriate for adults with medical or disabling conditions that do not require the intervention or services of a registered nurse or licensed rehabilitative therapist acting under the supervision of the client's physician. The adult day care center must offer and provide on site the following core services. These core services must meet the level of care needed by the client as assessed by the department case manager for waiver funded clients and do not exceed the scope of services that the adult day care center is able to provide.

(1) Assistance with activities of daily living:

(a) Locomotion outside of room, locomotion in room, walk in room;

(b) Body care;

(c) Eating;

(d) Repositioning;

(e) Medication management that does not require a licensed nurse;

(f) Transfer;

(g) Toileting;

(h) Personal hygiene at a level that ensures client safety while in attendance at the program; and

(i) Bathing at a level that ensures client safety and comfort while in attendance at the program.

(2) Social services on a consultation basis, which may include:

(a) Referrals to other providers for services not within the scope of Medicaid reimbursed adult day care services;

(b) Caregiver support and education; or

(c) Assistance with coping skills.

(3) Routine health monitoring with consultation from a registered nurse that a consulting nurse acting within the scope of practice can provide with or without a physician's order. Examples include:

(a) Obtaining baseline and routine monitoring information on client health status, such as vital signs, weight, and dietary needs;

(b) General health education such as providing information about nutrition, illnesses, and preventative care;

(c) Communicating changes in client health status to the client's caregiver;

(d) Annual and as needed updating of the client's medical record; or

(e) Assistance as needed with coordination of health services provided outside of the adult day care program.

(4) General therapeutic activities that an unlicensed person can provide or that a licensed person can provide with or without a physician's order. These services are planned for and provided based on the client's abilities, interests, and goals. Examples include:

(a) Recreational activities;

(b) Diversionary activities;

(c) Relaxation therapy;

(d) Cognitive stimulation; or

(e) Group range of motion or conditioning exercises.

(5) General health education that an unlicensed person can provide or that a licensed person can provide with or without a physician's order, including but not limited to topics such as:

(a) Nutrition;

(b) Stress management;

(c) Disease management skills; or

(d) Preventative care.

(6) A nutritional meal and snacks every four hours, including a modified diet if needed and within the scope of the program, as provided under WAC 388-71-0768;

(7) Supervision and/or protection if needed for client safety;

(8) Assistance with arranging transportation to and from the program; and

(9) First aid and provisions for obtaining or providing care in an emergency. NOTE: If the client requires the intervention or services of a registered nurse or licensed rehabili-

tative therapist acting under the supervision of a physician, consider adult day health services.

AMENDATORY SECTION (Amending WSR 05-11-082, filed 5/17/05, effective 6/17/05)

**WAC 388-71-0706 Adult day health—Services.** Adult day health is a supervised daytime program providing skilled nursing and rehabilitative therapy services in addition to core services. Adult day health services are only appropriate for adults with medical or disabling conditions that require the intervention or services of a registered nurse or licensed rehabilitative therapist acting under the supervision of the client's physician.

The adult day health center must offer and provide on site the following services (~~(listed in WAC 388-106-0810)~~):

- (1) All core services under WAC 388-71-0704;
- (2) Skilled nursing services other than routine health monitoring with nurse consultation;
- (3) At least one of the following skilled therapy services: physical therapy, occupational therapy, or speech-language pathology or audiology, as defined under chapters 18.74, 18.59 and 18.35 RCW; and
- (4) Psychological or counseling services, including assessing for psycho-social therapy need, dementia, abuse or neglect, and alcohol or drug abuse; making appropriate referrals; and providing brief, intermittent supportive counseling.

REPEALER

The following sections of the Washington Administrative Code are repealed:

WAC 388-71-0210	What is the purpose of WAC 388-71-0210 through 388-71-0260?
WAC 388-71-0215	What definitions apply to WAC 388-71-0210 through 388-71-0260?
WAC 388-71-0220	What is an assessment?
WAC 388-71-0225	What is the purpose of a comprehensive assessment?
WAC 388-71-0230	How are my needs for MPC services assessed?
WAC 388-71-0235	What is a service plan?
WAC 388-71-0240	What services may I receive under MPC as a child?
WAC 388-71-0245	What services are not covered under MPC for children?
WAC 388-71-0250	Am I eligible for MPC services?
WAC 388-71-0255	How do children remain eligible for MPC services?

WAC 388-71-0260

Are there limitations to MPC services for children?

AMENDATORY SECTION (Amending WSR 04-16-063 and 04-18-001, filed 7/30/04 and 8/19/04, effective 9/19/04)

**WAC 388-110-020 Definitions. "Adult residential care"** is a package of services provided by a boarding home that is licensed under chapter 18.20 RCW and that has a contract with the department under RCW 74.39A.020 to provide personal care services in accordance with Parts I and IV of this chapter.

**"Applicant"** means the individual, partnership, corporation or other entity which has applied for a contract with the department to provide assisted living services, enhanced adult residential care, enhanced adult residential care-specialized dementia care services, or adult residential care to state funded residents in a licensed boarding home.

**"Assisted living services"** is a package of services provided by a boarding home that has a contract with the department under RCW 74.39A.010 to provide personal care services, intermittent nursing services, and medication administration services in accordance with Parts I and II of this chapter. Assisted living services include housing for the resident in a private apartment-like unit.

**"Boarding home"** means the same as the definition found in RCW 18.20.020, or a boarding home located within the boundaries of a federally recognized Indian reservation and licensed by the tribe.

**"Case manager"** means the department staff person or designee assigned to negotiate, monitor, and facilitate a service plan for residents receiving services fully or partially paid for by the department.

**"Contractor"** means the individual, partnership, corporation, or other entity which is licensed by the department or tribe to operate the boarding home and contracts with the department to provide assisted living services, enhanced adult residential care, enhanced adult residential care-specialized dementia care services, or adult residential care to state funded residents in a licensed boarding home.

**"Department"** means the Washington state department of social and health services (DSHS).

**"Dignity"** means the quality or condition of being esteemed and respected in such a way as to validate the self-worth of the resident.

**"Enhanced adult residential care"** is a package of services provided by a boarding home that is licensed under chapter 18.20 RCW and that has a contract with the department to provide personal care services, intermittent nursing services, and medication administration services in accordance with Parts I and III of this chapter.

**"Enhanced adult residential care-specialized dementia care services"** is a package of service, including specialized dementia care assessment and care planning, personal care services, intermittent nursing services, medication administration services, specialized environmental features and accommodations, and activity programming. Enhanced adult residential care-specialized dementia care services are delivered only within:

(1) Contracted boarding homes that are dedicated solely to the care of individuals with dementia, including Alzheimer's disease, and that meet the requirements of parts I and III of this chapter; or

(2) Designated, separate units located within contracted boarding homes that are dedicated solely to the care of individuals with dementia, including Alzheimer's disease, and that meet the requirements of parts I and III of this chapter.

**"Homelike"** means an environment having the qualities of a home, including privacy, comfortable surroundings, and the opportunity to decorate one's living area and arrange furnishings to suit one's individual preferences. A homelike environment provides residents with an opportunity for self-expression, and encourages interaction with the community, family and friends.

**"Independence"** means free from the control of others and being able to assert one's own will, personality and preferences.

**"Individuality"** means the quality of being unique; the aggregate of qualities and characteristics that distinguishes one from others. Individuality is supported by modifying services to suit the needs or wishes of a specific individual.

**"Medication administration"** means the direct application of a prescribed medication, whether by injection, inhalation, ingestion, or any other means, to the body of a resident by a person legally authorized to do so.

**"Personal care services"** means the same as physical or verbal assistance with activities of daily living included under "personal care services" described in WAC ((388-72A-0035(1))) 388-106-0010. Personal care services do not include assistance with instrumental activities of daily living described in WAC ((388-72A-0035(2))) 388-106-0010, nor assistance with tasks that must be performed by a licensed health professional.

**"Resident"** means a person residing in a boarding home for whom services are paid for, in whole or in part, by the department under a contract for assisted living services, enhanced adult residential care, enhanced adult residential care-specialized dementia care services, or adult residential care. **"Resident"** includes former residents when examining complaints about admissions, readmissions, transfers or discharges. For decision-making purposes, the term **"resident"** includes the resident's surrogate decision maker in accordance with state law or at the resident's request.

AMENDATORY SECTION (Amending WSR 04-16-063, filed 7/30/04, effective 9/1/04)

**WAC 388-110-100 Discharge, social leave, and bed hold.** The contractor is not required to discharge (move out) and readmit a resident for absences of less than twenty-one consecutive days. The contractor must:

(1) Note an absence in a resident's record when a resident is absent from the boarding home for more than seventy-two consecutive hours;

(2) Obtain department approval for payment for social leave in excess of ((fifteen consecutive)) eighteen calendar days per year;

(3) Notify the department within one working day whenever the resident:

(a) Is hospitalized;

(b) Is discharged to another boarding home, nursing home or other health care facility;

(c) Dies; or

(d) Is missing from the boarding home and his or her whereabouts are unknown.

(4) Include the department's case manager in the development of a discharge (move out) plan, and have the case manager approve the plan before any required notice of discharge is issued to the resident, except in an emergency;

(5) Notify the medicaid resident of the boarding home's policies regarding bed-holds, consistent with subsections (6) and (7) of this section and WAC 388-105-0045 as soon as possible before, or as soon as practicable following hospitalization or discharge to a nursing home. The notification must include information concerning:

(a) Options for bed-hold payments, and

(b) Rights to return to the boarding home.

(6) Retain a bed or unit for a medicaid resident who is hospitalized or temporarily placed in a nursing home for up to twenty days when the medicaid resident is likely to return to the boarding home and the department makes payment to the boarding home for holding the bed or unit consistent with WAC 388-105-0045. If, prior to the end of the twenty days, the department determines, or the contractor determines and the department concurs, that the medicaid resident will likely not return to the boarding home:

(a) The department must terminate the bed-hold payment; and (b) The contractor may rent that bed or unit to another resident.

(7) Not seek third-party payment for the first twenty days of retaining the bed for a medicaid resident who is hospitalized or discharged to a nursing home and for whom the department is making a bed hold payment consistent with WAC 388-105-0045.

(a) The contractor may seek third-party payment consistent with RCW 18.20.290 and chapter 388-105 WAC to hold a bed or unit for the time following the first twenty days of a medicaid resident's absence for hospitalization or nursing home care.

(b) If third-party payment is not available, the ((contractor must readmit the)) medicaid resident may return to the first available and appropriate bed or unit if the medicaid resident:

(i) Continues to meet the boarding home's admission criteria; and

(ii) Chooses to return to the boarding home.

AMENDATORY SECTION (Amending WSR 04-16-063 and 04-18-001, filed 7/30/04 and 8/19/04, effective 9/19/04)

**WAC 388-110-220 Enhanced adult residential care service standards.** (1) In a boarding home with an enhanced adult residential care contract, the contractor must meet the requirements of parts I and III of this chapter, and for residents served under the enhanced adult residential care contract:

(a) Develop for each resident a negotiated service agreement that supports the principles of dignity, privacy, choice in decision making, individuality, and independence.

(b) Provide or arrange for, at no additional cost to the resident and consistent with the resident's negotiated service agreement and chapter 388-78A WAC:

- (i) Intermittent nursing services;
- (ii) Medication administration;
- (iii) Personal care services; and
- (iv) Supportive services that promote independence and self-sufficiency; and

(c) Not allow more than two residents per room.

(2) An enhanced adult residential care-specialized dementia care services contract is a distinct contract, separate from an enhanced adult residential care contract. In a boarding home with an enhanced adult residential care-specialized dementia care services contract, the contractor must:

(a) Meet the requirements of parts I and III of this chapter,

(b) Meet the requirements of subsection (1) of this section, and

(c) Maintain an enhanced adult residential care services contract or an assisted living services contract in addition to the enhanced adult residential care-specialized dementia care services contract.

(3) In a boarding home with an enhanced adult residential care-specialized dementia care services contract, for residents served under that contract, the contractor must:

(a) Complete a full assessment of residents as specified in chapter 388-78A WAC, at a minimum, on a semi-annual basis;

(b) Maintain awake staff twenty-four hours per day. The contractor must provide staffing that is adequate to respond to the assessed sleeping and waking patterns and needs of residents;

(c) Develop and implement policies and procedures:

- (i) To manage residents who may wander;
- (ii) To outline actions to be taken in case a resident elopes; and

(iii) To obtain consultative resources to address behavioral issues for residents. The contractor must include a plan that identifies the professional (i.e., clinical psychologist, psychiatrist, psychiatric nurse practitioner, or other behavioral specialist familiar with care of persons with dementia with complex or severe problems) who will provide the consultation, and when and how the consultation will be utilized.

(d) Ensure that each staff who works directly with residents has at least six hours of continuing education per year related to dementia, including Alzheimer's disease. This six hours of continuing education may be part of the ten hours of continuing education required by WAC 388-112-0205. Appropriate topics include, but are not limited to:

- (i) ~~((Aggressive behaviors and catastrophic reactions; (ii)))~~ Agitation: Caregiving strategies;
- (ii) Challenging behaviors: Strategies for managing aggression and sexual behavior;
- (iii) Delusions and hallucinations;
- (iv) ~~((Dementia))~~ Using problem-solving strategies in dementia care;
- (v) Depression and dementia;
- (vi) Fall prevention for people with dementia;
- (vii) Personal care as meaningful activity;
- (viii) Promoting adequate food and fluid consumption;

~~(ix) Promoting pleasant and purposeful activity; ((and))~~  
~~((ix))~~ (x) Resistance to care: Caregiving strategies; and  
(xi) Recognizing and assessing pain in people with dementia.

(e) Provide all necessary physical assistance with bathing and toilet use for residents who require caregivers to perform these activities and subtasks of these activities, and required oversight and supervision, encouragement and ~~((euing))~~ cueing. For the purposes of this subsection:

(i) "Bathing" has the same meaning as described in WAC ~~((388-72A-0035))~~ 388-106-0010; and

(ii) "Toilet use" has the same meaning as described in WAC ~~((388-72A-0035))~~ 388-106-0010.

(f) Routinely provide ~~((extensive))~~ assistance with eating as necessary, including required oversight and supervision, encouragement and ~~((euing))~~ cueing. The contractor must also provide all necessary physical assistance with eating on an occasional basis for residents who require total feeding assistance. However, the contractor is not required to provide ~~((tube feedings or intravenous nutrition nor provide))~~ total feeding assistance for an extended or indefinite period. As used in this section, eating has the same meaning as described in WAC 388-106-0010, except that the contractor is not required to provide tube feedings or intravenous nutrition.

~~((i) "Eating" has the same meaning as described in WAC 388-72A-0035, except that the contractor is not required to provide tube feedings or intravenous nutrition;~~

~~((ii) "Extensive assistance" has the same meaning as described in WAC 388-72A-0040.))~~

(g) Provide daily activities consistent with the functional abilities, interests, habits and preferences of the individual residents. The contractor must support the participation of residents and the resident council, if there is one, in the development of recreational and activity programs that reflect the needs and choices of residents. On a daily basis, the contractor must provide residents access to:

(i) Opportunities for independent, self-directed, activities.

(ii) Individual activities, in which a staff person or volunteer engages the resident in a planned and/or spontaneous activity of interest. Activities may include personal care activities that provide opportunities for purposeful and positive interactions; and

(iii) Group activities.

(h) Offer opportunities for activities that accommodate variations in a resident's mood, energy and preferences. The contractor must make appropriate activities available based upon the resident's individual schedule and interests. For example, individuals up at night must have access to staff support, food and appropriate activities;

(i) Make available multiple common areas, at least one of which is outdoors, that vary by size and arrangement such as: various size furniture groupings that encourage social interaction; areas with environmental cues that may stimulate activity, such as a resident kitchen or workshop; areas with activity supplies and props to stimulate conversation; a garden area; and paths and walkways that encourage exploration and walking. These areas must accommodate and offer opportunities for individual or group activity;

- (j) Ensure that the outdoor area for residents:
  - (i) Is accessible to residents without staff assistance;
  - (ii) Is surrounded by walls or fences at least seventy-two inches high;
  - (iii) Has areas protected from direct sunshine and rain throughout the day;
  - (iv) Has walking surfaces that are firm, stable, slip-resistant and free from abrupt changes, and are suitable for individuals using wheelchairs and walkers;
  - (v) Has suitable outdoor furniture;
  - (vi) Has plants that are not poisonous or toxic to humans; and
  - (vii) Has areas for appropriate outdoor activities of interest to residents, such as walking paths, raised garden or flower beds, bird feeders, etc.
- (k) Ensure that areas used by residents have a residential atmosphere, and residents have opportunities for privacy, socialization, and wandering behaviors;
- (l) Ensure any public address system in the area of specialized dementia care services is used only for emergencies;
- (m) Encourage residents' individualized spaces to be furnished and or decorated with personal items based on resident needs and preferences;
- (n) Ensure residents have access to their own rooms at all times without staff assistance; and
- (o) Make available and offer at no additional cost to the resident generic personal care items needed by the resident such as soap, shampoo, toilet paper, toothbrush, toothpaste, deodorant, sanitary napkins, and disposable razors. This does not include items covered by medical coupons or preclude residents from choosing to purchase their own personal care items.

AMENDATORY SECTION (Amending WSR 05-11-082, filed 5/17/05, effective 6/17/05)

**WAC 388-106-0010 What definitions apply to this chapter? "Ability to make self understood"** means how you make yourself understood to those closest to you; express or communicate requests, needs, opinions, urgent problems and social conversations, whether in speech, writing, sign language, symbols, or a combination of these including use of a communication board or keyboard:

- (a) Understood: You express ideas clearly;
- (b) Usually understood: You have difficulty finding the right words or finishing thoughts, resulting in delayed responses(⊖), or you require(⊕) some prompting to make self understood;
- (c) Sometimes understood: You have limited ability, but are able to express concrete requests regarding at least basic needs (e.g. food, drink, sleep, toilet);
- (d) Rarely/never understood. At best, understanding is limited to caregiver's interpretation of client specific sounds or body language (e.g. indicated presence of pain or need to toilet.)

**"Activities of daily living (ADL)"** means the following:

- (a) Bathing: How you take a full-body bath/shower, sponge bath, and transfer in/out of tub/shower.

(b) Bed mobility: How you move to and from a lying position, turn side to side, and position your body while in bed, in a recliner, or other type of furniture.

(c) Body care: How you perform with passive range of motion, applications of dressings and ointments or lotions to the body and pedicure to trim toenails and apply lotion to feet. In adult family homes, contracted assisted living, enhanced adult residential care, and enhanced adult residential care-specialized dementia care facilities, dressing changes using clean technique and topical ointments must be performed by a licensed nurse or through nurse delegation in accordance with chapter 246-840 WAC. Body care excludes:

- (i) Foot care if you are diabetic or have poor circulation;
- or
- (ii) Changing bandages or dressings when sterile procedures are required.

(d) Dressing: How you put on, fasten, and take off all items of clothing, including donning/removing prosthesis.

(e) Eating: How you eat and drink, regardless of skill. Eating includes any method of receiving nutrition, e.g., by mouth, tube or through a vein.

(f) Locomotion in room and immediate living environment: How you move between locations in your room and immediate living environment. If you are in a wheelchair, locomotion includes how self-sufficient you are once in your wheelchair.

(g) Locomotion outside of immediate living environment including outdoors: How you move to and return from more distant areas. If you are living in a boarding home or nursing facility (NF), this includes areas set aside for dining, activities, etc. If you are living in your own home or in an adult family home, locomotion outside immediate living environment including outdoors, includes how you move to and return from a patio or porch, backyard, to the mailbox, to see the next-door neighbor, etc.

(h) Walk in room, hallway and rest of immediate living environment: How you walk between locations in your room and immediate living environment.

(i) Medication management: Describes the amount of assistance, if any, required to receive medications, over the counter preparations or herbal supplements.

(j) Toilet use: How you use the toilet room, commode, bedpan, or urinal, transfer on/off toilet, cleanse, change pad, manage ostomy or catheter, and adjust clothes.

(k) Transfer: How you move between surfaces, i.e., to/from bed, chair, wheelchair, standing position. Transfer does not include how you move to/from the bath, toilet, or vehicle.

(l) Personal hygiene: How you maintain personal hygiene, including combing hair, brushing teeth, shaving, applying makeup, washing/drying face, hands (including nail care), and perineum (menses care). Personal hygiene does not include hygiene in baths and showers.

**"Aged person"** means a person sixty-five years of age or older.

**"Agency provider"** means a licensed home care agency or a licensed home health agency having a contract to provide long-term care personal care services to you in your own home.

**"Application"** means a written request for medical assistance or long-term care services submitted to the department by the applicant, the applicant's authorized representative, or, if the applicant is incompetent or incapacitated, someone acting responsibly for the applicant. The applicant must submit the request on a form prescribed by the department.

**"Assessment details"** means a summary of information that the department entered into the CARE assessment describing your needs.

**"Assessment or reassessment"** means an inventory and evaluation of abilities and needs based on an in-person interview in your own home or your place of residence, using CARE.

**"Assistance available"** means the amount of informal support available if the need is partially met. The department determines the amount of the assistance available using one of four categories:

- (a) Less than one-fourth of the time;
- (b) One-fourth to one-half of the time;
- (c) Over one-half of the time to three-fourths of the time;

or

(d) Over three-fourths ~~((of the time))~~ but not all of the time.

**"Assistance with body care"** means you need assistance with:

- (a) Application of ointment or lotions;
- (b) Trimming of toenails;
- (c) Dry bandage changes; or
- (d) Passive range of motion treatment.

**"Assistance with medication management"** means you need assistance managing your medications. You are scored as:

(a) Independent if you remember to take medications as prescribed and manage your medications without assistance.

(b) Assistance required if you need assistance from a nonlicensed provider to facilitate your self-administration of a prescribed, over the counter, or herbal medication, as defined in chapter 246-888 WAC. Assistance required includes reminding or coaching you, handing you the medication container, opening the container, using an enabler to assist you in getting the medication into your mouth, alteration of a medication for self-administration, and placing the medication in your hand. This does not include assistance with intravenous or injectable medications. You must be aware that you are taking medications.

(c) Self-directed medication assistance/administration if you are a person with a functional disability who is capable of and who chooses to self-direct your medication assistance/administration.

(d) Must be administered if you must have medications placed in your mouth or applied or instilled to your skin or mucus membrane. Administration must either be performed by a licensed professional or delegated by a registered nurse to a qualified caregiver (per chapter 246-840 WAC). Intravenous or injectable medications may never be delegated. Administration may also be performed by a family member or unpaid caregiver if facility licensing regulations allow.

**"Authorization"** means an official approval of a departmental action, for example, a determination of client eligibil-

ity for service or payment for a client's long-term care services.

**"Blind person"** means a person determined blind as described under WAC 388-511-1105 by the division of disability determination services of the medical assistance administration.

**"Categorically needy"** means the status of a person who is eligible for medical care under Title XIX of the Social Security Act. See WAC 388-475-0100 and chapter 388-513 WAC.

**"Client"** means an applicant for service or a person currently receiving services from the department.

**"Current"** means a behavior occurred within seven days of the CARE assessment date, including the day of the assessment. Behaviors that the department designates as current must include information about:

- (a) Whether the behavior is easily altered or not easily altered; and
- (b) The frequency of the behavior.

**"Decision making"** means your ability and actual performance in making everyday decisions about tasks or activities of daily living. The department determines whether you are:

(a) Independent: Decisions about your daily routine are consistent and organized; reflecting your lifestyle, choices, culture, and values.

(b) Modified independence/difficulty in new situations: You have an organized daily routine, are able to make decisions in familiar situations, but experience some difficulty in decision making when faced with new tasks or situations.

(c) Moderately impaired/poor decisions; unaware of consequences: Your decisions are poor and you require reminders, cues and supervision in planning, organizing and correcting daily routines. You attempt to make decisions, although poorly.

(d) Severely impaired/no or few decisions ~~((or preferences regarding ADLs))~~: Decision making is severely impaired; you never/rarely make decisions.

**"Department"** means the state department of social and health services, aging and disability services administration or its designee.

**"Designee"** means area agency on aging.

**"Difficulty"** means how difficult it is or would be for you to perform an instrumental activity of daily living (IADL). This is assessed as:

- (a) No difficulty in performing the activity;
- (b) Some difficulty in performing the activity (e.g., you need some help, are very slow, or fatigue easily); or
- (c) Great difficulty in performing the activity (e.g., little or no involvement in the activity is possible).

**"Disabling condition"** means you have a medical condition which prevents you from self performance of personal care tasks without assistance.

**"Estate recovery"** means ~~((after the client's death, the department's activity in recouping funds that were expended for long-term care services provided to the client during the client's lifetime, per WAC 388-527-2742))~~ the department's process of recouping the cost of Medicaid and long-term care benefit payments from the estate of the deceased client. See chapter 388-527 WAC.



**"Home health agency"** means a licensed:

(a) Agency or organization certified under Medicare to provide comprehensive health care on a part-time or intermittent basis to a patient in the patient's place of residence and reimbursed through the use of the client's medical identification card; or

(b) Home health agency, certified or not certified under Medicare, contracted and authorized to provide:

(i) Private duty nursing; or

(ii) Skilled nursing services under an approved Medicaid waiver program.

**"Income"** means income as defined under WAC 388-500-0005.

**"Individual provider"** means a person employed by you to provide personal care services in your own home. See WAC 388-71-0500 through 388-71-05909.

**"Disability"** is described under WAC 388-511-1105.

**"Informal support"** means a person or resource that is available to provide assistance without home and community program funding. The person or resource providing the informal support must be age 18 or older.

**"Institution"** means medical facilities, nursing facilities, and institutions for the mentally retarded. It does not include correctional institutions. See medical institutions in WAC 388-500-0005.

**"Instrumental activities of daily living (IADL)"** means routine activities performed around the home or in the community and includes the following:

(a) Meal preparation: How meals are prepared (e.g., planning meals, cooking, assembling ingredients, setting out food, utensils, and cleaning up after meals). NOTE: The department will not authorize this IADL to plan meals or clean up after meals. You must need assistance with actual meal preparation.

(b) Ordinary housework: How ordinary work around the house is performed (e.g., doing dishes, dusting, making bed, tidying up, laundry).

(c) Essential shopping: How shopping is completed to meet your health and nutritional needs (e.g., selecting items). Shopping is limited to brief, occasional trips in the local area to shop for food, medical necessities and household items required specifically for your health, maintenance or well-being. This includes shopping with or for you.

(d) Wood supply: How wood is supplied (e.g., splitting, stacking, or carrying wood) when you use wood as the sole source of fuel for heating and/or cooking.

(e) Travel to medical services: How you travel by vehicle to a physician's office or clinic in the local area to obtain medical diagnosis or treatment-includes driving vehicle yourself, traveling as a passenger in a car, bus, or taxi.

(f) Managing finances: How bills are paid, checkbook is balanced, household expenses are managed. The department cannot pay for any assistance with managing finances.

(g) Telephone use: How telephone calls are made or received (with assistive devices such as large numbers on telephone, amplification as needed).

**"Long-term care services"** means the services administered directly or through contract by the aging and disability services administration and identified in WAC 388-106-0015.

**"Medicaid"** is defined under WAC 388-500-0005.

**"Medically necessary"** is defined under WAC 388-500-0005.

**"Medically needy (MN)"** means the status of a person who is eligible for a federally matched medical program under Title XIX of the Social Security Act, who, but for income above the categorically needy level, would be eligible as categorically needy. Effective January 1, 1996, an AFDC-related adult is not eligible for MN.

**"Own home"** means your present or intended place of residence:

(a) In a building that you rent and the rental is not contingent upon the purchase of personal care services as defined in this section;

(b) In a building that you own;

(c) In a relative's established residence; or

(d) In the home of another where rent is not charged and residence is not contingent upon the purchase of personal care services as defined in this section.

**"Past"** means the behavior occurred from eight days to five years of the assessment date. For behaviors indicated as past, the department determines whether the behavior is addressed with current interventions or whether no interventions are in place.

**"Personal aide"** is defined in RCW 74.39.007.

**"Personal care services"** means physical or verbal assistance with activities of daily living (ADL) and instrumental activities of daily living (IADL) due to your functional limitations. Assistance is evaluated with the use of assistive devices.

**"Physician"** is defined under WAC 388-500-0005.

**"Plan of care"** means assessment details and service summary generated by CARE.

**"Provider or provider of service"** means an institution, agency, or person:

(a) Having a signed department contract to provide long-term care client services; and

(b) Qualified and eligible to receive department payment.

**"Residential facility"** means a licensed adult family home under department contract or licensed boarding home under department contract to provide assisted living, adult residential care or enhanced adult residential care.

**"Self performance for ADLs"** means what you actually did in the last seven days before the assessment, not what you might be capable of doing. Coding is based on the level of performance that occurred three or more times in the seven-day period and does not include support provided as defined in WAC 388-106-0010. Your self performance level is scored as:

(a) Independent if you received no help or oversight, or if you needed help or oversight only once or twice;

(b) Supervision if you received oversight (monitoring or standby), encouragement, or cueing three or more times;

(c) Limited assistance if you were highly involved in the activity and given physical help in guided maneuvering of limbs or other non-weight bearing assistance involving physical contact between you and others on three or more occasions. For bathing, limited assistance means physical help is limited to transfer only;

(d) Extensive assistance if you performed part of the activity, but on three or more occasions, you needed weight bearing support or you received full performance of the activity during part, but not all, of the activity. For bathing, extensive assistance means you needed physical help with part of the activity (other than transfer);

(e) Total dependence if you received full caregiver performance of the activity and all subtasks during the entire seven-day period from others. Total dependence means complete nonparticipation by you in all aspects of the ADL; or

(f) Activity did not occur if you or others did not perform an ADL over the last seven days before your assessment. The activity may not have occurred because:

- (i) You were not able (e.g., walking, if paralyzed);
- (ii) No provider was available to assist; or
- (iii) You declined assistance with the task.

**"Self performance for IADLs"** means what you actually did in the last ~~((seven))~~ thirty days before the assessment, not what you might be capable of doing. Coding is based on the level of performance that occurred three or more times in the ~~((seven))~~ thirty-day period. Your self performance is scored as:

(a) Independent if you received no help, set-up help, or supervision;

(b) ~~((Supervision if you received set-up help or arrangements only;~~

~~(c) Limited assistance if you sometimes performed the activity yourself and other times needed assistance))~~ Set-up help/arrangements only if on some occasions you did your own set-up/arrangement and at other times you received help from another person;

(c) Limited assistance if on some occasions you did not need any assistance but at other times in the last thirty days you required some assistance;

(d) Extensive assistance if you were involved in performing the activity, but required cueing/supervision or partial assistance at all times;

(e) Total dependence if you needed the activity fully performed by others; or

(f) Activity did not occur if you or others did not perform the activity in the last ~~((seven))~~ thirty days before the assessment.

**"Service summary"** is CARE information which includes: Contacts (e.g. emergency contact), services the client is eligible for, number of hours or residential rates, personal care needs, the list of formal and informal providers and what tasks they will provide, a provider schedule, referral needs/information, and dates and agreement to the services.

**"SSI-related"** is defined under WAC ~~((388-500-0005))~~ 388-475-0050.

**"Status"** means the amount of informal support available. The department determines whether the ADL or IADL is:

(a) Met, which means the ADL or IADL will be fully provided by an informal support;

(b) Unmet, which means an informal support will not be available to provide assistance with the identified ADL or IADL;

(c) Partially met, which means an informal support will be available to provide some assistance, but not all, with the identified ADL or IADL; or

(d) Client declines, which means you do not want assistance with the task.

**"Supplemental Security Income (SSI)"** means the federal program as described under WAC 388-500-0005.

**"Support provided"** means the highest level of support provided (to you) by others in the last seven days before the assessment, even if that level of support occurred only once.

(a) No set-up or physical help provided by others;

(b) Set-up help only provided, which is the type of help characterized by providing you with articles, devices, or preparation necessary for greater self performance of the activity ~~((such as)). For example, set-up help includes but is not limited to giving or holding out an item ((that you take from others)) or cutting food);~~

(c) One-person physical assist provided;

(d) Two- or more person physical assist provided; or

(e) Activity did not occur during entire seven-day period.

**"You/your"** means the client.

AMENDATORY SECTION (Amending WSR 05-19-045, filed 9/15/05, effective 10/16/05)

**WAC 388-106-0015 What long-term care services does the department provide?** The department provides long-term care services through programs that are designed to help you remain in the community. These programs offer an alternative to nursing home care (which is described in WAC 388-106-0350 through 388-106-0360). You may receive services from any of the following:

(1) **Medical personal care (MPC)** is a Medicaid state plan program authorized under RCW 74.09.520. Clients eligible for this program may receive personal care in their own home or in a residential facility.

(2) **Community options program entry system (COPEs)** is a Medicaid waiver program authorized under RCW 74.39A.030. Clients eligible for this program may receive personal care in their own home or in a residential facility.

(3) **Medically needy residential waiver (MNRW)** is a Medicaid waiver program authorized under RCW 74.39.041. Clients eligible for this program may receive personal care in a residential facility.

(4) **Medically needy in-home waiver (MNIW)** is a Medicaid waiver program authorized under RCW 74.09.700. Clients eligible for this program may receive personal care in their own home.

(5) **Chore** is a state-only funded program authorized under RCW 74.39A.110. Grandfathered clients may receive assistance with personal care in their own home.

(6) **Volunteer chore** is a state-funded program that provides volunteer assistance with household tasks to eligible clients.

(7) **Program of all-inclusive care for the elderly (PACE)** is a Medicaid/Medicare managed care program authorized under 42 CFR 460.2. Clients eligible for this program may receive personal care and medical services in their

own home, in residential facilities, and in adult day health centers.

(8) **Adult day health** is a supervised daytime program providing skilled nursing and rehabilitative therapy services in addition to core services outlined in WAC 388-106-0800.

(9) **Adult day care** is a supervised daytime program providing core services, as defined under WAC 388-106-0800.

(10) **GAU-funded residential care** is a state-funded program authorized under WAC 388-400-0025. Clients eligible for this program may receive personal care services in an adult family home or an adult residential care facility.

(11) **Residential care discharge allowance** is a service that helps eligible clients to establish or resume living in their own home.

(12) **Private duty nursing** is a Medicaid service that provides an alternative to institutionalization in a hospital or nursing facility setting. Clients eligible for this program may receive at least four continuous hours of skilled nursing care on a day to day basis in their own home.

(13) **Senior Citizens Services Act (SCSA)** is a program authorized under chapter 74.38 RCW. Clients eligible for this program may receive community-based services as defined in RCW 74.38.040.

(14) **Respite program** is a program authorized under RCW 74.41.040 and WAC 388-106-1200. This program provides relief care for unpaid family or other caregivers of adults with a functional disability.

(15) **Programs for persons with developmental disabilities** are discussed in chapter ~~((388-825))~~ 388-823 through 388-853 WAC.

(16) **Nursing facility.**

(17) **Medicare/Medicaid Integration Project (MMIP)** is a DSHS prepaid managed care program, authorized under 42 CFR Part 438, that integrates medical and long-term care services for clients who are sixty-five years of age or older and eligible for Medicare (Parts A and B) and Medicaid.

AMENDATORY SECTION (Amending WSR 05-11-082, filed 5/17/05, effective 6/17/05)

**WAC 388-106-0035 May I receive personal care services through any of the long-term care programs when I am out of the state of Washington?** (1) You may receive personal care assistance through any long-term care programs in WAC 388-106-0015 subsections (1) through (5) when temporarily traveling out of state for less than thirty days, as long as you:

(a) Individual provider is contracted with the state of Washington;

(b) Travel plans are coordinated with ~~((the department))~~ your case manager prior to departure;

(c) Services are authorized on your plan of care prior to departure; and

(d) Services are strictly for your personal care and do not include your provider's travel time, expenses.

(2) You may not receive personal care services outside of the United States.

AMENDATORY SECTION (Amending WSR 05-11-082, filed 5/17/05, effective 6/17/05)

**WAC 388-106-0050 What is an assessment?** ~~(1) An assessment is an ((inventory and evaluation of abilities and needs based on an))~~ (1) An assessment is an in-person interview in your home or your place of residence that is conducted by the department to inventory and evaluate your ability to care for yourself. The department will assess you at least annually or more often when there are significant changes to your ability to care for yourself.

(2) Between assessments, the department may modify your current assessment without an in-person interview in your home or place of residence. The reasons that the department may modify your current assessment without conducting an in-person interview in your home or place of residence include but are not limited to the following:

(a) Errors made by department staff in coding the information from your in-person interview;

(b) New information requested by department staff at the time of your assessment and received after completion of the in-person interview (e.g. medical diagnosis);

(c) Changes in the level of informal support available to you; or

(d) Clarification of the coding selected.

(3) When the department modifies your current assessment, it will notify you using a Planned Action Notice (DSHS 14-405) of the modification regardless of whether the modification results in a change to your benefits. You will also receive a new service summary and assessment details.

AMENDATORY SECTION (Amending WSR 05-11-082, filed 5/17/05, effective 6/17/05)

**WAC 388-106-0065 What is the process for conducting an assessment?** The department:

(1) Will assess you using a department-prescribed assessment tool, titled the comprehensive assessment reporting evaluation (CARE).

(2) May request the assessment be conducted in private. However, you have the right to request that third parties be present ~~((e.g. a friend, a family member, or a legal representative)))~~.

(3) Has the right to end the assessment if behaviors by any party are impeding the assessment process. If an assessment is terminated, the department will reschedule.

AMENDATORY SECTION (Amending WSR 05-11-082, filed 5/17/05, effective 6/17/05)

**WAC 388-106-0130 How does the department determine the number of hours I may receive for in-home care?** (1) The department assigns a base number of hours to each classification group as described in WAC 388-106-0125.

(2) The department will deduct from the base hours to account for your informal supports, as defined in WAC 388-106-0010, as follows:

(a) The CARE tool determines the adjustment for informal supports by determining the amount of assistance available to meet your needs, assigns it a numeric percentage, and

reduces the base hours assigned to the classification group by the numeric percentage. The department has assigned the fol-

lowing numeric values for the amount of assistance available for each ADL and IADL:

<b>Meds</b>	<b>Self Performance</b>	<b>Status</b>	<b>Assistance Available</b>	<b>Value Percentage</b>
Self administration of medications	Rules for all codes apply except independent is not counted	Unmet	N/A	1
		Met	N/A	0
		Decline	N/A	0
		Partially met	<1/4 time	.9
			1/4 to 1/2 time	.7
	1/2 to 3/4 time	.5		
	>3/4 time	.3		
<b>Unscheduled ADLs</b>	<b>Self Performance</b>	<b>Status</b>	<b>Assistance Available</b>	<b>Value Percentage</b>
Bed mobility, transfer, walk in room, eating, toilet use	Rules apply for all codes except: Did not occur/client not able and Did not occur/no provider = 1; Did not occur/client declined and independent are not counted.	Unmet	N/A	1
		Met	N/A	0
		Decline	N/A	0
		Partially met	<1/4 time	.9
			1/4 to 1/2 time	.7
	1/2 to 3/4 time	.5		
	>3/4 time	.3		
<b>Scheduled ADLs</b>	<b>Self Performance</b>	<b>Status</b>	<b>Assistance Available</b>	<b>Value Percentage</b>
Dressing, personal hygiene, bathing	Rules apply for all codes except: Did not occur/client not able and Did not occur/no provider = 1; Did not occur/client declined and independent are not counted.	Unmet	N/A	1
		Met	N/A	0
		Decline	N/A	0
		Partially met	<1/4 time	.75
			1/4 to 1/2 time	.55
	1/2 to 3/4 time	.35		
	>3/4 time	.15		
<b>IADLs</b>	<b>Self Performance</b>	<b>Status</b>	<b>Assistance Available</b>	<b>Value Percentage</b>
Meal preparation, Ordinary housework, Essential shopping*	Rules for all codes apply except independent is not counted.	Unmet	N/A	1
		Met	N/A	0
		Decline	N/A	0
		Partially met	<1/4 time	.3
			1/4 to 1/2 time	.2
	1/2 to 3/4 time	.1		
	>3/4 time	.05		
<b>IADLs</b>	<b>Self Performance</b>	<b>Status</b>	<b>Assistance Available</b>	<b>Value Percentage</b>
Travel to medical	Rules for all codes apply except independent is not counted.	Unmet	N/A	1
		Met	N/A	0
		Decline	N/A	0
		Partially met	<1/4 time	.9
			1/4 to 1/2 time	.7
			1/2 to 3/4 time	.5
			>3/4 time	.3

**Key:**

> means greater than

< means less than

\*Results in 5% deduction for each IADL from the base hours. Remaining hours may be used for completion of household and personal care tasks.

(b) To determine the amount of reduction for informal support, the value percentage is divided by the number of qualifying ADLs and IADLs needs. The result is value A. Value A is then subtracted from one. This is value B. Value B is divided by three. This is value C. Value A and Value C are summed. This is value D. Value D is multiplied by the "base hours" assigned to your classification group and the result is base in-home care hours reduced for informal supports.

(3) Also, the department will adjust in-home base hours for the following shared living circumstances:

(a) If there is more than one client living in the same household, the status under subsection (2)(a) of this section must be met or partially met for the following IADLs:

- (i) Meal preparation,
- (ii) Housekeeping,
- (iii) Shopping, and
- (iv) Wood supply.

(b) If you and your paid provider live in the same household, the status under subsection (2)(a) of this section must be met for the following IADLs:

- (i) Meal preparation,
- (ii) Housekeeping,
- (iii) Shopping, and
- (iv) Wood supply.

(c) When there is more than one client living in the same household and your paid provider lives in your household, the status under subsection (2)(a) of this section must be met for the following IADLs:

- (i) Meal preparation,
- (ii) Housekeeping,
- (iii) Shopping, and
- (iv) Wood supply.

(4) After deductions are made to your base hours, as described in subsections (2) and (3), the department may add on hours based on your living environment:

Condition	Status	Assistance Available	Add On Hours
Offsite laundry facilities, which means the client does not have facilities in own home and the caregiver is not available to perform any other personal or household tasks while laundry is done.	Unmet	N/A	8
Client is >45 minutes from essential services (which means he/she lives more than 45 minutes one-way from a full-service market).	Unmet	N/A	5
	Met	N/A	0
	Partially met	<1/4 time	5
		between 1/4 to 1/2 time	4
		between 1/2 to 3/4 time	2
>3/4 time		2	
Wood supply used as sole source of heat.	Unmet	N/A	8
	Met	N/A	0
	Declines	N/A	0
	Partially met	<1/4 time	8
		between 1/4 to 1/2 time	6
		between 1/2 to 3/4 time	4
>3/4 time		2	

(5) The result of actions under subsections (2), (3), and (4) is the maximum number of hours that can be used to develop your plan of care. The department must take into account cost effectiveness, client health and safety, and program limits in determining how hours can be used to meet your identified needs.

(6) You and your case manager will work to determine what services you choose to receive if you are eligible. The hours may be used to authorize:

(a) Personal care services from a home care agency provider and/or an individual provider.

(b) Home delivered meals (i.e. a half hour from the available hours for each meal authorized).

(c) Adult day care (i.e. a half hour from the available hours for each hour of day care authorized).

(d) A home health aide if you are eligible per WAC 388-106-0300 or WAC 388-106-0500.

(e) A private duty nurse (PDN) if you are eligible per WAC 388-71-0910 and WAC 388-71-0915 or WAC 388-551-3000 (i.e. one hour from the available hours for each hour of PDN authorized.).

**Reviser's note:** The typographical error in the above section occurred in the copy filed by the agency and appears in the Register pursuant to the requirements of RCW 34.08.040.

AMENDATORY SECTION (Amending WSR 05-11-082, filed 5/17/05, effective 6/17/05)

**WAC 388-106-0200 What services may I receive under Medicaid personal care (MPC)?** You may be eligible to receive only the following services under Medicaid personal care (MPC):

(1) Personal care services, as defined in WAC 388-106-0010, in your own home and, as applicable, assistance with personal care tasks while you are out of the home accessing community resources or working.

(2) Personal care services in one of the following residential care facilities:

(a) Adult family homes; or

(b) A licensed boarding home that has contracted with the department to provide adult residential care services.

(3) Nursing services, if you are not already receiving this type of service from another resource. A registered nurse may visit you and perform any of the following activities. The frequency and scope of the nursing services is based on your individual need as determined by your CARE assessment and any additional collateral contact information obtained by your case manager:

(a) Nursing assessment/reassessment;

(b) Instruction to you and your providers;

(c) Care coordination and referral to other health care providers;

(d) Skilled treatment, only in the event of an emergency. A skilled treatment is care that would require authorization, prescription, and supervision by an authorized practitioner prior to its provision by a nurse, for example, medication administration or wound care such as debridement. In non-emergency situations, the nurse will refer the need for any skilled medical or nursing treatments to a health care provider, a home health agency or other appropriate resource;

(e) File review; and/or

(f) Evaluation of health-related care needs affecting service planning and delivery.

AMENDATORY SECTION (Amending WSR 05-11-082, filed 5/17/05, effective 6/17/05)

**WAC 388-106-0213 How are my needs assessed if I am a child applying for MPC services?** If you are a child applying for MPC services, the department will complete a CARE assessment and:

(1) Consider and document the role of your legally responsible natural/step/adoptive parent(s).

(2) Code your needs as met based on the guidelines outlined in the following table:

Activities of Daily Living (ADLs)

Ages	0	1	2	3	4	5	6	7	8	9	10	11	12	13	14	15	16	17
■ = Code status as Met																		
<b>Medication Management</b>																		
Independent, supervision, limited, extensive, or total	■	■	■	■	■	■	■	■	■	■	■	■	■	■	■	■	■	■
<b>Locomotion in Room</b> <sup>Note</sup>																		
Independent, supervision, limited or extensive	■	■	■	■														
Total	■	■																
<b>Locomotion Outside Room</b> <sup>Note</sup>																		
Independent or supervision	■	■	■	■	■	■												
Limited or extensive	■	■	■	■														
Total	■	■																
<b>Walk in Room</b> <sup>Note</sup>																		
Independent, supervision, limited or extensive	■	■	■	■														
Total	■	■																
<b>Bed Mobility</b>																		
Independent, supervision, limited or extensive	■	■	■															
Total	■	■																
<b>Transfers</b>																		
Independent, supervision, limited, extensive or total & under 30 pounds (Total & over 30 pounds = no age limit)	■	■	■															
<b>Toilet Use</b>																		
Support provided for nighttime wetting only (Independent, supervision, limited, extensive( <del>-or total</del> )))	■	■	■	■	■	■	■	■										

Activities of Daily Living (ADLs)

**Ages**

■ = Code status as Met

Independent, supervision, limited, extensive

Total

**Eating**

Independent, supervision, limited, extensive, or total

**Bathing**

Independent or supervision

Physical assistance all/part

Total

**Dressing**

Independent or supervision

Limited or extensive

Total

**Personal Hygiene**

Independent or supervision

Limited or extensive

Total

	0	1	2	3	4	5	6	7	8	9	10	11	12	13	14	15	16	17
Independent, supervision, limited, extensive	■	■	■	■	■	■												
Total	■	■	■	■														
Independent, supervision, limited, extensive, or total	■	■	■															
Independent or supervision	■	■	■	■	■	■	■	■	■	■	■	■						
Physical assistance all/part	■	■	■	■	■	■	■	■										
Total	■	■	■	■	■													
Independent or supervision	■	■	■	■	■	■	■	■	■	■	■	■						
Limited or extensive	■	■	■	■	■	■	■	■										
Total	■	■	■	■	■													
Independent or supervision	■	■	■	■	■	■	■	■	■	■	■	■						
Limited or extensive	■	■	■	■	■	■	■	■										
Total	■	■	■	■	■													

Instrumental Activities of Daily Living

**Ages**

■ = Code status as Met

**Telephone**

Independent, supervision, limited, extensive, or total

**Transportation**

Independent, supervision, limited, extensive, or total

**Shopping**

Independent, supervision, limited, extensive, or total

**Wood Supply**

Independent, supervision, limited, extensive, or total

**Housework**

Independent, supervision, limited, extensive, or total

**Finances**

Independent, supervision, limited, extensive, or total

**Meal Preparation**

Independent, supervision, limited, extensive, or total

	0	1	2	3	4	5	6	7	8	9	10	11	12	13	14	15	16	17
Independent, supervision, limited, extensive, or total	■	■	■	■	■	■	■	■	■	■	■	■	■	■	■	■	■	■
Independent, supervision, limited, extensive, or total	■	■	■	■	■	■	■	■	■	■	■	■	■	■	■	■	■	■
Independent, supervision, limited, extensive, or total	■	■	■	■	■	■	■	■	■	■	■	■	■	■	■	■	■	■
Independent, supervision, limited, extensive, or total	■	■	■	■	■	■	■	■	■	■	■	■	■	■	■	■	■	■
Independent, supervision, limited, extensive, or total	■	■	■	■	■	■	■	■	■	■	■	■	■	■	■	■	■	■
Independent, supervision, limited, extensive, or total	■	■	■	■	■	■	■	■	■	■	■	■	■	■	■	■	■	■
Independent, supervision, limited, extensive, or total	■	■	■	■	■	■	■	■	■	■	■	■	■	■	■	■	■	■

NOTE: If the activity did not occur, the department codes self performance as total and status as met.

	Ages																	
	0	1	2	3	4	5	6	7	8	9	10	11	12	13	14	15	16	17
<b>Additional guidelines based on age</b>																		
<b>Any foot care needs</b>																		
Status Need met	■	■	■	■	■	■	■	■	■	■	■	■	■	■	■	■	■	■
<b>Any skin care (other than feet)</b>																		
Status Need met	■	■	■	■	■	■	■	■	■	■	■	■	■	■	■	■	■	■
<b>Speech/Hearing</b>																		
Score comprehension as understood	■	■	■															

	Ages																	
	0	1	2	3	4	5	6	7	8	9	10	11	12	13	14	15	16	17
<u>MMSE</u>	■	■	■	■	■	■	■	■	■	■	■	■	■	■	■	■	■	■
can be administered = no																		
<b>Memory</b>																		
Short term memory ok	■	■	■	■	■	■	■	■	■	■	■	■	■	■	■	■	■	■
Long term memory ok	■	■	■	■	■	■	■	■	■	■	■	■	■	■	■	■	■	■
<b>Depression</b>																		
Select interview = unable to obtain	■	■	■	■	■	■	■	■	■	■	■	■	■	■	■	■	■	■
<b>Decision making</b>																		
Rate how client makes decisions = independent	■	■	■	■	■	■	■	■	■	■	■	■	■	■	■	■	■	■
<b>Bladder/Bowel</b>																		
Support provided for nighttime wetting only - Individual management = Does not need/use	■	■	■	■	■	■	■	■	■	■	■	■	■	■	■	■	■	■
Support provided for daytime wetting - Individual Management = Does not need/use	■	■	■	■	■	■	■	■	■	■	■	■	■	■	■	■	■	■
<b>Treatment</b>																		
Range of motion	■	■	■	■														

(3) In addition, determine that the status and assistance available are met or partially met over three-fourths of the time, when you are living with your legally responsible natural/step/adoptive parent(s).

(4) Will not code mental health therapy, behaviors, or depression if you are in foster care.

**NEW SECTION**

**WAC 388-106-0215 When do MPC services start?**

Your eligibility for MPC begins the date the department authorizes services.

**AMENDATORY SECTION** (Amending WSR 05-11-082, filed 5/17/05, effective 6/17/05)

**WAC 388-106-0300 What services may I receive under community options program entry system (COPEs) when I live in my own home?** When you live in your own home, you may be eligible to receive only the following services under COPEs:

(1) Personal care services as defined in WAC 388-106-0010 in your own home and, as applicable, while you are out of the home accessing community resources or working.

(2) Adult day care if you meet the eligibility requirements under WAC 388-106-0805.

(3) Environmental modifications, if the minor physical adaptations to your home:

- (a) Are necessary to ensure your health, welfare and safety;
- (b) Enable you to function with greater independence in the home;
- (c) Directly benefit you medically or remedially;
- (d) Meet applicable state or local codes; and
- (e) Are not adaptations or improvements, which are of general utility or add to the total square footage.

(4) Home delivered meals, providing nutritional balanced meals, limited to one meal per day, if:

- (a) You are homebound and live in your own home;
  - (b) You are unable to prepare the meal;
  - (c) You don't have a caregiver (paid or unpaid) available to prepare this meal; and
  - (d) Receiving this meal is more cost-effective than having a paid caregiver.
- (5) Home health aide service tasks in your own home, if the service tasks:

- (a) Include assistance with ambulation, exercise, self-administered medications and hands-on personal care;
- (b) Are beyond the amount, duration or scope of Medicaid reimbursed home health services as described in WAC 388-551-2120 and are in addition to those available services;
- (c) Are health-related. Note: Incidental services such as meal preparation may be performed in conjunction with a health-related task as long as it is not the sole purpose of the aide's visit; and
- (d) Do not replace Medicare home health services.
- (6) Personal emergency response system (PERS), if the service is necessary to enable you to secure help in the event of an emergency and if you:
  - (a) Live alone in your own home; or
  - (b) Are alone, in your own home, for significant parts of the day and have no regular provider for extended periods of time.
- (7) Skilled nursing, if the service is:
  - (a) Provided by a registered nurse or licensed practical nurse under the supervision of a registered nurse; and
  - (b) Beyond the amount, duration or scope of Medicaid-reimbursed home health services as provided under WAC 388-551-2100.
- (8) Specialized durable and nondurable medical equipment and supplies under WAC 388-543-1000, if the items are:



- (a) Medically necessary under WAC 388-500-0005;
  - (b) Necessary for: Life support; to increase your ability to perform activities of daily living; or to perceive, control, or communicate with the environment in which you live;
  - (c) Directly medically or remedially beneficial to you; and
  - (d) In addition to and do not replace any medical equipment and/or supplies otherwise provided under Medicaid and/or Medicare.
- (9) Training needs identified in CARE or in a professional evaluation, which meet a therapeutic goal such as:
- (a) Adjusting to a serious impairment;
  - (b) Managing personal care needs; or
  - (c) Developing necessary skills to deal with care providers.
- (10) Transportation services, ~~((#))~~ when the service:
- (a) Provides ~~((you))~~ access to community services and resources to meet your therapeutic goal;
  - (b) Is not ~~((diversional))~~ diverting in nature; and
  - (c) Is in addition to and does not replace the Medicaid-brokered transportation or transportation services available in the community.
- (11) Nurse delegation services, when:
- (a) You are receiving personal care from a registered or certified nursing assistant who has completed nurse delegation core training;
  - (b) Your medical condition is considered stable and predictable by the delegating nurse; and
  - (c) Services are provided in compliance with WAC 246-840-930.
- (12) Nursing services, when you are not already receiving this type of service from another resource. A registered nurse may visit you and perform any of the following activities~~((:))~~. The frequency and scope of the nursing services is based on your individual need as determined by your CARE assessment and any additional collateral contact information obtained by your case manager.
- (a) Nursing assessment/reassessment;
  - (b) Instruction to you and your providers;
  - (c) Care coordination and referral to other health care providers;
  - (d) Skilled treatment, only in the event of an emergency. A skilled treatment is care that would require authorization, prescription, and supervision by an authorized practitioner prior to its provision by a nurse, for example, medication administration or wound care such as debridement. In none-emergency situations, the nurse will refer the need for any skilled medical or nursing treatments to a health care provider, a home health agency or other appropriate resource.
  - (e) File review; and/or
  - (f) Evaluation of health-related care needs affecting service plan and delivery.
- (13) Community transition services, if you are being discharged from the nursing facility or hospital and if services are necessary for you to set up your own home. Services:
- (a) May include: Safety deposits, utility set-up fees or deposits, health and safety assurances such as pest eradication, allergen control or one-time cleaning prior to occupancy, moving fees, furniture, essential furnishings, and

basic items essential for basic living outside the institution; and

(b) Do not include rent, recreational or ~~((diversional))~~ diverting items such as TV, cable or VCR's.

AMENDATORY SECTION (Amending WSR 05-11-082, filed 5/17/05, effective 6/17/05)

**WAC 388-106-0305 What services may I receive under COPES if I live in a residential facility?** If you live in one of the following residential facilities: A licensed boarding home contracted with the department to provide assisted living, enhanced adult residential care, enhanced adult residential care-specialized dementia care or an adult family home, you may be eligible to receive only the following services under COPES:

- (1) Personal care services as defined under WAC 388-106-0010.
- (2) Specialized durable and nondurable medical equipment and supplies under WAC 388-543-1000, when the items are:
  - (a) Medically necessary under WAC 388-500-0005; and
  - (b) Necessary: For life support; to increase your ability to perform activities of daily living; or to perceive, control, or communicate with the environment in which you live; and
  - (c) Directly medically or remedially beneficial to you; and
  - (d) In addition to and do not replace any medical equipment and/or supplies otherwise provided under Medicaid and/or Medicare; and
  - (e) In addition to and do not replace the services required by the department's contract with a residential facility.
- (3) Training needs identified in CARE or in a professional evaluation, that are in addition to and do not replace the services required by the department's contract with the residential facility and that meet a therapeutic goal such as:
  - (a) Adjusting to a serious impairment;
  - (b) Managing personal care needs; or
  - (c) Developing necessary skills to deal with care providers.
- (4) Transportation services, when the service:
  - (a) Provides ~~((you))~~ access to community services and resources to meet a therapeutic goal;
  - (b) Is not ~~((diversional))~~ diverting in nature;
  - (c) Is in addition to and does not replace the Medicaid-brokered transportation or transportation services available in the community; and
  - (d) Does not replace the services required by DSHS contract in residential facilities.
- (5) Skilled nursing, when the service is:
  - (a) Provided by a registered nurse or licensed practical nurse under the supervision of a registered nurse;
  - (b) Beyond the amount, duration or scope of Medicaid-reimbursed home health services as provided under WAC 388-551-2100; and
  - (c) In addition to and does not replace the services required by the department's contract with the residential facility (e.g. intermittent nursing services as described in WAC 388-78A-2310).

(6) Nursing services, when you are not already receiving this type of service from another resource. A registered nurse may visit you and perform any of the following activities(=). The frequency and scope of the nursing services is based on your individual need as determined by your CARE assessment and any additional collateral contact information obtained by your case manager.

- (a) Nursing assessment/reassessment;
- (b) Instruction to you and your providers;
- (c) Care coordination and referral to other health care providers;
- (d) Skilled treatment, only in the event of an emergency. A skilled treatment is care that would require authorization, prescription, and supervision by an authorized practitioner prior to its provision by a nurse, for example, medication administration or wound care such as debridement. In none-emergency situations, the nurse will refer the need for any skilled medical or nursing treatments to a health care provider, a home health agency or other appropriate resource.
- (e) File review; and/or
- (f) Evaluation of health-related care needs affecting service plan and delivery.

(7) Community transition services, if you are being discharged from the nursing facility or hospital and if services are necessary for you to live in a residential facility. Services:

- (a) May include: Safety deposits, utility set up fees or deposits, health and safety assurances such as pest eradication, allergen control or one time cleaning prior to occupancy, moving fees, furniture, essential furnishings, and basic items essential for basic living outside the institution.
- (b) Do not include rent, recreational or (~~diversional~~) diverting items such as TV, cable or VCR's.

AMENDATORY SECTION (Amending WSR 05-11-082, filed 5/17/05, effective 6/17/05)

**WAC 388-106-0400 What services may I receive under medically needy residential waiver (MNRW)?** You may be eligible to receive only the following MNRW services in one of the following residential facilities: A licensed boarding home contracted with the department to provide assisted living, enhanced residential care, enhanced adult residential care-specialized dementia care or an adult family home:

- (1) Personal care services as defined in WAC 388-106-0010.
- (2) Specialized durable and nondurable medical equipment and supplies under WAC 388-543-1000, when the items are:
  - (a) Medically necessary under WAC 388-500-0005; and
  - (b) Necessary: For life support; to increase your ability to perform activities of daily living; or to perceive, control, or communicate with the environment in which you live;
  - (c) Directly medically or remedially beneficial to you;
  - (d) In addition to and do not replace any medical equipment and/or supplies otherwise provided under Medicaid and/or Medicare; and
  - (e) In addition to and do not replace the services required by the department's contract with the residential facility.

(3) Training needs identified in CARE or in a professional evaluation that are in addition to and do not replace services required by the department's contract with the residential facility and that meet a therapeutic goal such as:

- (a) Adjusting to a serious impairment;
- (b) Managing personal care needs; or
- (c) Developing necessary skills to deal with care providers.
- (4) Transportation services, when the service:
  - (a) Provides (~~you~~) access to community services and resources provided to meet a therapeutic goal;
  - (b) Is not (~~diversional~~) diverting in nature;
  - (c) Is in addition to and does not replace the Medicaid-brokered transportation or transportation services available in the community; and
  - (d) Does not replace the services required by the department's contract with a residential facility.
- (5) Skilled nursing, when the service is:
  - (a) Provided by a registered nurse or licensed practical nurse under the supervision of a registered nurse;
  - (b) Beyond the amount, duration or scope of Medicaid-reimbursed home health services as provided under WAC 388-551-2120; and
  - (c) In addition to and does not replace the services required by the department's contract with the residential facility (e.g. intermittent nursing services as described in WAC 388-78A-2310).

(6) Nursing services, when you are not already receiving this type of service from another resource. A registered nurse may visit you and perform any of the following activities(=). The frequency and scope of the nursing services is based on your individual need as determined by your CARE assessment and any additional collateral contact information obtained by your case manager.

- (a) Nursing assessment/reassessment;
- (b) Instruction to care providers and clients;
- (c) Care coordination and referral to other health care providers;
- (d) Skilled treatment, only in the event of an emergency. A skilled treatment is care that would require authorization, prescription, and supervision by an authorized practitioner prior to its provision by a nurse, for example, medication administration or wound care such as debridement. In none-emergency situations, the nurse will refer the need for any skilled medical or nursing treatments to a health care provider, a home health agency or other appropriate resource.
- (e) File review; and/or
- (f) Evaluation of health-related care needs affecting service plan and delivery.
- (7) Community transition services, if you are being discharged from the nursing facility or hospital and if services are necessary for you to live in a residential facility. Services:
  - (a) May include: Safety deposits, utility set up fees or deposits, health and safety assurances such as pest eradication, allergen control or one time cleaning prior to occupancy, moving fees, furniture, essential furnishings, and basic items essential for basic living outside the institution.
  - (b) Do not include rent, recreational or (~~diversional~~) diverting items such as TV, cable or VCR's.

AMENDATORY SECTION (Amending WSR 05-11-082, filed 5/17/05, effective 6/17/05)

**WAC 388-106-0500 What services may I receive under medically needy in-home waiver (MNIW)?** You may be eligible to receive only the following medically needy in-home waiver (MNIW) services in your own home:

(1) Personal care services as defined in WAC 388-106-0010 in your own home and, as applicable, while you are out of the home accessing community resources or working.

(2) Adult day care if you meet the eligibility requirements under WAC 388-106-0805.

(3) Environmental modifications, if the minor physical adaptations to your home:

(a) Are necessary to ensure your health, welfare and safety;

(b) Enable you to function with greater independence in the home;

(c) Directly benefit you medically or remedially;

(d) Meet applicable state or local codes; and

(e) Are not adaptations or improvements, which are of general utility or add to the total square footage.

(4) Home delivered meals, providing nutritional balanced meals, limited to one meal per day, if:

(a) You are homebound and live in your own home;

(b) You are unable to prepare the meal;

(c) You don't have a caregiver (paid or unpaid) available to prepare this meal; and

(d) Receiving this meal is more cost-effective than having a paid caregiver.

(5) Home health aide service, if the service tasks:

(a) Include assistance with ambulation, exercise, self-administered medications and hands on personal care;

(b) Are beyond the amount, duration or scope of Medicaid reimbursed home health services (WAC 388-551-2120) and are in addition to those available services;

(c) Are health-related. Note: Incidental services such as meal preparation may be performed in conjunction with a health-related task as long as it is not the sole purpose of the aide's visit; and

(d) Do not replace Medicare home health services.

(6) Personal emergency response system (PERS), if the service is necessary to enable you to secure help in the event of an emergency and if you:

(a) Live alone in your own home; or

(b) Are alone, in your own home, for significant parts of the day and have no regular provider for extended periods of time.

(7) Skilled nursing, if the service is:

(a) Provided by a registered nurse or licensed practical nurse under the supervision of a registered nurse; and

(b) Beyond the amount, duration or scope of Medicaid-reimbursed home health services as provided under WAC 388-551-2120.

(8) Specialized durable and nondurable medical equipment and supplies under WAC 388-543-1000, if the items are:

(a) Medically necessary under WAC 388-500-0005;

(b) Necessary: For life support; to increase your ability to perform activities of daily living; or to perceive, control, or communicate with the environment in which you live;

(c) Directly medically or remedially beneficial to you; and

(d) In addition to and do not replace any medical equipment and/or supplies otherwise provided under Medicaid and/or Medicare.

(9) Training needs identified in CARE or in a professional evaluation, which meet a therapeutic goal such as:

(a) Adjusting to a serious impairment;

(b) Managing personal care needs; or

(c) Developing necessary skills to deal with care providers.

(10) Transportation services if you live in your own home, ~~((#))~~ when the service:

(a) Provides ~~((you))~~ access to community services and resources to meet a therapeutic goal;

(b) Is not ~~((diversional))~~ diverting in nature;

(c) Is in addition to and does not replace the Medicaid-brokered transportation or transportation services available in the community.

(11) Nurse delegation services when:

(a) You are receiving personal care from a registered or certified nursing assistant who has completed nurse delegation core training;

(b) Your medical condition is considered stable and predictable by the delegating nurse; and

(c) Services are provided in compliance with WAC 246-840-930.

(12) Nursing services, when you are not already receiving this type of service from another resource. A registered nurse may visit you and perform any of the following activities~~((:))~~. The frequency and scope of the nursing services is based on your individual need as determined by your CARE assessment and any collateral contact information obtained by your case manager.

(a) Nursing assessment/reassessment;

(b) Instruction to you and your providers;

(c) Care coordination and referral to other health care providers;

(d) Skilled treatment, only in the event of an emergency. A skilled treatment is care that would require authorization, prescription, and supervision by an authorized practitioner prior to its provision by a nurse, for example, medication administration or wound care such as debridement. In non-emergency situations, the nurse will refer the need for any skilled medical or nursing treatments to a health care provider, a home health agency or other appropriate resource;

(e) File review; and/or

(f) Evaluation of health-related care needs affecting service planning and delivery.

(13) Community transition services, if you are being discharged from the nursing facility or hospital and if services are necessary for you to set up your own home. Services:

(a) May include: Safety deposits, utility set up fees or deposits, health and safety assurances such as pest eradication, allergen control or one time cleaning prior to occupancy, moving fees, furniture, essential furnishings, and basic items essential for basic living outside the institution.

(b) Do not include rent, recreational or ~~((diversional))~~ diverting items such as TV, cable or VCR's.

AMENDATORY SECTION (Amending WSR 05-11-082, filed 5/17/05, effective 6/17/05)

**WAC 388-106-0705 Am I eligible for PACE services?**

To qualify for Medicaid-funded PACE services, you must apply for an assessment by contacting your local home and community services office. The department will assess and determine whether you:

- (1) Are age:
  - (a) Fifty-five or older, and blind or have a disability, as defined in WAC 388-511-1105, SSI-related eligibility requirements; or
  - (b) Sixty-five or older.
- (2) Need nursing facility level of care as defined in WAC 388-106-0355 (~~(- Note: If you are already enrolled, but no longer need nursing facility care, you may still be eligible for PACE services if the department reasonably expects you to need nursing facility care within the next six months in the absence of continued PACE coverage);~~);
- (3) Live within the designated service area of the PACE provider;
- (4) Meet financial eligibility requirements. This means the department will assess your finances (~~(and)~~), determine if your income and resources fall within the limits (~~(set in WAC 388-515-1505)~~), and determine the amount you may be required to contribute, if any, toward the cost of your care as described in WAC 388-515-1505;
- (5) Not be enrolled in any other (~~(medical coverage plan that purchases services on a prepaid basis (e.g., prepaid health plan))~~) Medicare or Medicaid prepayment plan or optional benefit; and
- (6) Agree to receive services exclusively through the PACE provider and the PACE provider's network of contracted providers.

AMENDATORY SECTION (Amending WSR 05-11-082, filed 5/17/05, effective 6/17/05)

**WAC 388-106-0715 How do I (~~(disenroll from)~~) end my enrollment in the PACE program?** (1) You may choose to voluntarily (~~(disenroll from)~~) end your enrollment in the PACE program without cause at any time. To do so, you must give the PACE provider written notice. If you give notice:

- (a) Before the fifteenth of the month, (~~(disenrollment is)~~) the department will end your enrollment effective at the end of the month; or
  - (b) After the fifteenth, (~~(disenrollment is not)~~) the department will end your enrollment effective until the end of the following month.
- (2) (~~(You may also be involuntarily disenrolled from the program by the PACE provider.)~~) Your enrollment may also end involuntarily if you:
- (a) Move out of the designated service area or are out of the service area for more than thirty consecutive days, unless the PACE provider agrees to a longer absence due to extenuating circumstances;
  - (b) Engage in disruptive or threatening behavior such that the behavior jeopardizes your health or safety, or the safety of others;

- (c) Fail to comply with your plan of care or the terms of the PACE enrollment agreement;
  - (d) Fail to pay or make arrangements to pay your part of the costs after the thirty-day grace period;
  - (e) Become financially ineligible for Medicaid services, unless you choose to pay privately;
  - (f) Are enrolled with a provider that loses its license and/or contract; or
  - (g) No longer meet the nursing facility level of care requirement as defined in WAC 388-106-0205 (~~(and are not deemed PACE eligible)~~).
- (3) For any of the above reasons, the PACE provider must give you written notice, explaining that they are terminating benefits. If the provider gives you notice:
- (a) Before the fifteenth of the month, then (~~(you may be disenrolled)~~) the department will end your enrollment at the end of the month; or
  - (b) After the fifteenth, then (~~(you may be disenrolled)~~) the department will end your enrollment at the end of the following month.
- (4) Before the PACE provider can involuntarily (~~(disenroll you from)~~) end your enrollment in the PACE program, the department must review and approve (~~(all proposed involuntary disenrollments)~~) it.

NEW SECTION

**WAC 388-106-1303 What responsibilities do I have as a client of the department?** As a client of the department, you have a responsibility to:

- (1) Give us enough information to assess your needs;
- (2) Let the social services worker into your home so that your needs can be assessed;
- (3) Follow your care plan;
- (4) Not act in a way that puts anyone in danger;
- (5) Provide a safe work place;
- (6) Tell your social services worker if there is a change in:
  - (a) Your medical condition;
  - (b) The help you get from family or other agencies;
  - (c) Where you live; or
  - (d) Your financial situation.
- (7) Tell your social services worker if someone else makes medical or financial decision for you;
- (8) Choose a qualified provider;
- (9) Keep provider background checks private;
- (10) Tell your social services worker if you are having problems with your provider; and
- (11) Choose your own health care. Tell your social services worker when you do not do what your doctor says.

**WSR 05-24-011**  
**WITHDRAWAL OF PROPOSED RULES**  
**DEPARTMENT OF**  
**NATURAL RESOURCES**  
 (By the Code Reviser's Office)  
 [Filed November 29, 2005, 9:55 a.m.]

WAC 332-30-151, proposed by the Department of Natural Resources in WSR 05-11-067 appearing in issue 05-11 of the State Register, which was distributed on June 1, 2005, is withdrawn by the code reviser's office under RCW 34.05.335 (3), since the proposal was not adopted within the one hundred eighty day period allowed by the statute.

Kerry S. Radcliff, Editor  
 Washington State Register

**WSR 05-24-031**  
**PROPOSED RULES**  
**DEPARTMENT OF LICENSING**  
 (Geologist Licensing Board)  
 [Filed November 30, 2005, 1:25 p.m.]

Original Notice.

Preproposal statement of inquiry was filed as WSR 05-17-063 and 05-17-064.

Title of Rule and Other Identifying Information: Amending WAC 308-15-030 How do I apply for a geologist license?, to clarify language; 308-15-050 What is the examination process to be licensed as a geologist?, to allow examination applicants to pay exam costs directly to the National Association of State Boards of Geology (ASBOG) for the examinations that we contract with ASBOG to administer; and 308-15-150 Fees, to allow for a suspension in renewal fees until July 1, 2008, but still allow the board to be self-reporting.

Hearing Location(s): Department of Licensing, 405 Black Lake Boulevard, Room 209, Olympia, WA 98502, on January 11, 1006 [2006], at 1:00 p.m.

Date of Intended Adoption: January 16, 2006.

Submit Written Comments to: Joseph Vincent Jr., P.O. Box 9045, Olympia, WA, e-mail jvincent@dol.wa.gov, fax (360) 664-4195, by December 21, 2005.

Assistance for Persons with Disabilities: Contact Joan Robinson by December 21, 2005, TTY (360) 664-8885 or (360) 664-1387.

Purpose of the Proposal and Its Anticipated Effects, Including Any Changes in Existing Rules: Delete language no longer applicable; clarify existing language.

Anticipated effects will be to make the language consistent with the way we do business and to clarify the rule language for the applicant, registrants and the public.

Reflect suspension of renewal fees.

Reasons Supporting Proposal: The cost of the examinations are charged directly to the candidates for registration and allow for a suspension in renewal fees.

Statutory Authority for Adoption: RCW 18.220.040 Directors authority.

Statute Being Implemented: Chapter 18.220 RCW.

Rule is not necessitated by federal law, federal or state court decision.

Name of Proponent: Geologist Licensing Board, Department of Licensing, governmental.

Name of Agency Personnel Responsible for Drafting and Implementation: Joan Robinson, Olympia, Washington, (360) 664-1387; and Enforcement: Joseph Vincent Jr., Olympia, Washington, (360) 664-1386.

No small business economic impact statement has been prepared under chapter 19.85 RCW. The Geologist Licensing Board does regulate businesses only individuals.

A cost-benefit analysis is not required under RCW 34.05.328. This statute does not apply to Department of Licensing.

November 30, 2005  
 Joseph Vincent Jr.  
 Administrator

AMENDATORY SECTION (Amending WSR 05-01-174, filed 12/21/04, effective 1/21/05)

**WAC 308-15-030 How do I apply for a geologist license?** (1) Review the available options for licensure:

- (a) Examination in WAC 308-15-050; and
- (b) Reciprocity in WAC 308-15-060.

(2) Complete and submit your application according to the directions in the geologist application packet, which is available on the geologist web site and upon request from the board office.

(3) Verify you meet minimum educational requirements by having your official sealed transcripts sent directly to the board office from your college or university. Transcripts from schools outside the United States or Canada must be evaluated by a board-approved evaluation service. The evaluation service must send the original evaluation and a copy of the transcripts directly to the board office.

(4) Solicit personal references and verifications of experience in the format and on the forms specified in the application instructions. Verifications must be sent to the board directly from the originating source.

(5) If applying for a license by reciprocity, solicit verification of your current license or certification and your examination scores on the form provided in the application packet. Verification must be sent directly to the board from the issuing jurisdiction.

(6) If applying for a specialty license, submit a project list on the forms provided in the application packet to show you meet the minimum requirements of professional specialty practice of a character satisfactory to the board.

(7) If requested by the board, submit one or more reports you contributed to or solely prepared.

(8) If applying for a license by examination, your complete application, as described in subsection (9) of this section, must be received by the board at least ~~((sixty))~~ ninety calendar days before the date of the examination.

(9) An application is not complete and will not be considered until all of the following are received by the board:

- (a) Application, signed and dated, and without omissions;

- (b) Application fee and, if applying for a specialty by examination, the examination fee specified in WAC 308-15-150;
- (c) Transcripts sent directly from the colleges or universities;
- (d) Personal references sent directly from the originators;
- (e) Verification of experience sent directly from the verifiers;
- (f) If applying by reciprocity, verification of exam scores and license or certification in another jurisdiction;
- (g) If applying for a specialty license, project list; and
- (h) Other documentation requested by the board.

AMENDATORY SECTION (Amending WSR 05-01-174, filed 12/21/04, effective 1/21/05)

**WAC 308-15-050 What is the examination process to be licensed as a geologist?** You must take and pass the ASBOG examination. The examination currently consists of two parts: Fundamentals of Geology and Practice of Geology. Each part of the examination is four hours long. Information on the examination is available on the ASBOG web site.

(1) **Applying for the examination:** You may either:

(a) Apply to take the Fundamentals of Geology exam after you meet the minimum educational requirements for licensure, and the Practice of Geology exam after you meet the experience requirements outlined in WAC 308-15-040.

(i) To apply to take the Fundamentals of Geology exam, you must provide the board with an application; a certified copy of your transcripts, sent directly from your college or university; and the application ~~((and examination))~~ fee((s)) listed in WAC 308-15-150. You do not need to submit employment and experience verification forms or personal references.

(ii) After you meet the minimum experience requirements, you may apply for the Practice of Geology examination by submitting the remaining application documents and ~~((applicable examination))~~ application fee; or

(b) Apply to take both parts of the ASBOG examination after you meet all other licensure requirements outlined in WAC 308-15-040 by submitting a completed license application packet and ~~((applicable examination and license))~~ application fee((s)).

(2) **Fees:** You must submit the ~~((applicable))~~ application fee((s)) with your application prior to the application deadline. ~~((If you do not qualify to take the examination, only your examination fee will be refunded.))~~ Fees are listed in WAC 308-15-150. Following approval of your application you must submit your examination fees directly to ASBOG prior to the deadline specified by ASBOG.

(3) **Special accommodations:** If you have a disability, the board will provide accommodations consistent with the Americans with Disabilities Act. You must request special accommodations at least ninety days before the examination date.

(4) **Notification of scoring:** The board will notify you by mail of your examination score within ninety days of taking the examination.

(5) **Failing the examination:**

~~((a) You may request that your examination be manually graded by submitting a written request and the fee specified in WAC 308-15-150.~~

~~(b))~~ You may apply to retake the examination by submitting a written request and the administrative fee((s)) for reexamination specified in WAC 308-15-150. You must submit the examination fee directly to ASBOG by the deadline specified by ASBOG.

AMENDATORY SECTION (Amending WSR 05-01-174, filed 12/21/04, effective 1/21/05)

**WAC 308-15-150 Fees. (1) Suspension of fees.** Effective March 1, 2006, the listed fees shown in subsection (2) of this section are suspended and replaced with the following:

**Renewal Fees**

<u>Annual renewal fee for geologist</u>	<u>\$20.00</u>
<u>Annual renewal for each specialty</u>	<u>\$25.00</u>
<u>Annual renewal for geologist, with late fee (if paid ninety days or more after due date)</u>	<u>\$40.00</u>
<u>Annual renewal fee for each specialty, with late fee (if paid ninety days or more after due date)</u>	<u>\$50.00</u>

The fees set forth in this section shall revert back to the fee amounts shown in WAC 308-15-150 on July 1, 2008.

**(2) Fees.**

<b>Type of Fee</b>	<b>Amount</b>
<b>Application fees - includes initial license</b>	
Application fee for geologist <del>((--))</del> <u>(applying by examination)</u>	\$100.00
Application fee for each specialty <del>((--))</del> <u>(applying by examination)</u>	\$100.00
Application fee for geologist <del>((--))</del> <u>(applying by reciprocity)</u>	\$200.00
Application fee for each specialty <del>((--))</del> <u>(applying by reciprocity)</u>	\$150.00
<b>Examination fees</b>	
<del>((Fundamentals of Geology (vendor charge)</del>	<del>\$125.00</del>
<del>Practice of Geology (vendor charge)</del>	<del>\$150.00</del>
<u>Fees for the fundamentals of geology and practice of geology examinations are submitted directly to ASBOG</u>	
Administration fee for reexamination	\$65.00
<del>((Late fee (if scheduled less than thirty days before examination date -- vendor charge)</del>	<del>\$25.00</del>
Manual regrade (vendor charge)	\$50.00
Specialty examination (hydrogeologist or engineering geologist exam)	\$300.00

<b>Type of Fee</b>	<b>Amount</b>
( <del>Administrative fee for regrade</del> )	\$15.00)
<b>Renewal fees</b>	
Annual renewal fee for geologist	\$100.00
Annual renewal fee for each specialty	\$85.00
Annual renewal for geologist, with late fee ( <i>if paid ninety days or more after due date</i> )	\$200.00
Annual renewal for each specialty, with late fee ( <i>if paid ninety days or more after due date</i> )	\$170.00
<b>Miscellaneous fees</b>	
Duplicate license or wall certificate . . .	\$25.00
Certification of license records to other jurisdictions . . . . .	\$45.00
Proctor examination for another jurisdiction . . . . .	\$100.00

2930; Implementation: Ron McQueen, 1111 Washington Street, Olympia, (360) 902-2204; and Enforcement: Bruce Bjork, 1111 Washington Street, Olympia, (360) 902-2373.

A small business economic impact statement has been prepared under chapter 19.85 RCW.

Small Business Economic Impact Statement

See WSR 05-21-140.

A cost-benefit analysis is not required under RCW 34.05.328. These rule proposals do not affect hydraulics.

November 30, 2005

Evan Jacoby

Rules Coordinator

**WSR 05-24-043**  
**PROPOSED RULES**  
**DEPARTMENT OF**  
**FISH AND WILDLIFE**

[Filed November 30, 2005, 4:10 p.m.]

Continuance of WSR 05-21-140.

Preproposal statement of inquiry was filed as WSR 05-10-006.

Title of Rule and Other Identifying Information: Scientific collection permit rules. This filing is for purposes of continuing the hearing from December 2005 to February 2006.

Hearing Location(s): Natural Resource Building, 1111 Washington Street, Olympia, WA, on February 10-11, 2006, begins 8:00 a.m. February 10, 2006.

Date of Intended Adoption: February 10, 2006.

Submit Written Comments to: Evan Jacoby, Rules Coordinator, 600 Capitol Way, Olympia, WA 98501-1091, e-mail [jacobesj@dfw.wa.gov](mailto:jacobesj@dfw.wa.gov), fax (360) 902-2155, by February 3, 2006.

Assistance for Persons with Disabilities: Contact Susan Yeager by January 27, 2006, TTY (360) 902-2207 or (360) 902-2267.

Purpose of the Proposal and Its Anticipated Effects, Including Any Changes in Existing Rules: Consolidate the current two rules into one, and provide definitions for clarity.

Reasons Supporting Proposal: Bring organization and clarity to current system and assist in implementing an automated license issuance system.

Statutory Authority for Adoption: RCW 77.12.047.

Statute Being Implemented: RCW 77.12.047.

Rule is not necessitated by federal law, federal or state court decision.

Name of Proponent: Department of Fish and Wildlife, governmental.

Name of Agency Personnel Responsible for Drafting: Evan Jacoby, 1111 Washington Street, Olympia, (360) 902-

**WSR 05-24-046**  
**PROPOSED RULES**  
**DEPARTMENT OF AGRICULTURE**

[Filed November 30, 2005, 4:48 p.m.]

Continuance of WSR 05-18-060.

Preproposal statement of inquiry was filed as WSR 05-11-034.

Title of Rule and Other Identifying Information: The department is proposing the following amendments to chapter 16-228 WAC, General pesticide rules, that affect the application of pesticides near schools, hospitals, nursing homes, adult and child day care centers:

- Adding the definition of "responsible person" to WAC 16-228-1010;
- Modifying the definition of "fumigant" in WAC 16-228-1010; and
- Adding a new section WAC 16-228-1221 Must an applicator notify schools, hospitals, nursing homes and day care centers prior to an application of certain pesticides? Requires an applicator to provide notification of application for certain applications of specified pesticides near schools, hospitals, nursing homes and adult and child day care centers.

The department held public hearings on the rules on the following dates: The public hearing dates, times and locations for the proposed amendments to chapter 16-228 WAC, General pesticide rules, are listed in the following table:

DATE	TIME	LOCATION
Wednesday, November 2, 2005	3:00 p.m.	Wenatchee Valley Community College Room: Anderson 2047 1300 5th Street Wenatchee, WA 98801
Wednesday, November 2, 2005	7:00 p.m.	Wenatchee Valley Community College Room: Anderson 2047 1300 5th Street Wenatchee, WA 98801
Monday, November 7, 2005	7:00 p.m.	Washington State Department of Agriculture 21 North 1st Avenue Suite 236 Yakima, WA 98902

DATE	TIME	LOCATION
Monday, November 14, 2005	3:00 p.m.	Washington State Department of Agriculture Second Floor, Room 259 1111 Washington Street S.W. Olympia, WA 98504-2560

In addition, the department received written comments on the rules through November 15, 2005. In accordance with RCW 34.05.335(2), the department is continuing to review and consider the testimony and submissions at the public hearings and other written comments.

The department intends to continue its consideration of all these submissions and has continued the intended date of adoption to December 30, 2005.

Date of Intended Adoption: December 30, 2005.

Purpose of the Proposal and Its Anticipated Effects, Including Any Changes in Existing Rules: The proposed amendments result from pesticide stakeholders expressing concerns to the department that those parts of chapter 16-228 WAC regulating airblast applications need to be more restrictive. The proposed amendments:

Add notification requirements for specified applications of "Danger/Poison" pesticides near schools, hospitals, nursing homes and adult and child day care centers;

Add a definition of "responsible person" to WAC 16-228-1010;

Modify the definition of "fumigant" to be consistent with RCW 17.21.020(20); and

Establish a mechanism to reduce the possibility that sensitive human populations will accidentally be exposed to pesticides as a result of pesticide drift.

Reasons Supporting Proposal: The department obtained stakeholder comments regarding the need to modify WAC 16-228-1220(4) so it would be more restrictive. A committee of interested parties worked with the department to develop proposed rule amendments. Although it does not represent a consensus opinion of the committee, the new section 16-228-1221 is the final result of the committee's effort.

Statutory Authority for Adoption: RCW 17.21.030 (1)(a) and chapter 34.05 RCW.

Statute Being Implemented: RCW 17.21.030 (1)(a).

Rule is not necessitated by federal law, federal or state court decision.

Agency Comments or Recommendations, if any, as to Statutory Language, Implementation, Enforcement, and Fiscal Matters: The proposed rule language was a compromise based upon the work of a representative stakeholder committee. The department is prevented from proposing some additional airblast restrictions requested by some committee members because those restrictions exceed the department's statutory authority. Only the legislature has the authority to amend chapter 17.21 RCW.

Name of Proponent: Washington State Department of Agriculture, governmental.

Name of Agency Personnel Responsible for Drafting: Ann Wick, 1111 Washington Street, Olympia, WA, (360) 902-2051; Implementation and Enforcement: Cliff Weed, 1111 Washington Street, Olympia, WA, (360) 902-2036.

No small business economic impact statement has been prepared under chapter 19.85 RCW. RCW 19.85.030 (1)(a)

requires the department to prepare a small business economic impact statement (SBEIS) for proposed rules that impose a more than minor cost on businesses in an industry. The department has analyzed the economic impact of the proposed amendments and concluded that the cost imposed by the notification requirements in WAC 16-228-1221 are "not more than minor" and do not have a disproportionate impact on small businesses, therefore, a formal SBEIS is not required. Affected sites (schools, hospitals, nursing homes and adult and child day care centers) are not required to take any action if they choose not to. However, by following the notification requirements in WAC 16-228-1221, affected sites could benefit from substantial cost savings by avoiding possible pesticide exposure incidents.

A cost-benefit analysis is not required under RCW 34.05.328. The Washington State Department of Agriculture is not a listed agency under RCW 34.05.328 (5)(a)(i).

November 30, 2005

Bob Arrington

Assistant Director

**WSR 05-24-047**  
**PROPOSED RULES**  
**DEPARTMENT OF**  
**RETIREMENT SYSTEMS**  
[Filed December 1, 2005, 8:10 a.m.]

Original Notice.

Preproposal statement of inquiry was filed as WSR 05-20-060.

Title of Rule and Other Identifying Information: WAC 415-111-220 How do I choose a defined contribution rate?

Hearing Location(s): Department of Retirement Systems, 6835 Capitol Boulevard, Conference Room 115, Tumwater, WA, on January 10, 2006, at 1:30 p.m.

Date of Intended Adoption: January 11, 2006.

Submit Written Comments to: Leslie L. Saeger, Rules Coordinator, Department of Retirement Systems, P.O. Box 48380, Olympia, WA 98504-8380, e-mail [leslies@drs.wa.gov](mailto:leslies@drs.wa.gov), fax (360) 753-3166, by 5:00 p.m., on January 10, 2006.

Assistance for Persons with Disabilities: Contact Leslie Saeger, Rules Coordinator, by December 30, 2005, TDD (360) 664-7291, TTY (360) 586-5450, phone (360) 664-7291.

Purpose of the Proposal and Its Anticipated Effects, Including Any Changes in Existing Rules: This amendment clarifies that once a PERS or SERS Plan 3 member chooses a contribution rate, or is assigned the base rate of 5%, the member may not change that contribution rate unless he/she changes employers. This amendment is required by an IRS decision on the tax-qualified status of PERS Plan 2 and 3 and SERS Plan 2 and 3. (RCW 41.34.090).

Statutory Authority for Adoption: RCW 41.50.050(5).

Statute Being Implemented: RCW 41.34.040 and 41.34.090.

Rule is not necessitated by federal law, federal or state court decision.



Name of Proponent: Department of Retirement Systems, governmental.

Name of Agency Personnel Responsible for Drafting: Leslie Saeger, P.O. Box 48380, Olympia, WA 98504-8380, (360) 664-7291; Implementation and Enforcement: Dave Nelsen, P.O. Box 48380, Olympia, WA 98504-8380, (360) 664-7291.

No small business economic impact statement has been prepared under chapter 19.85 RCW. These rules have no effect on businesses.

A cost-benefit analysis is not required under RCW 34.05.328. The Department of Retirement Systems is not one of the named departments in RCW 34.05.328.

November 29, 2005

Leslie Saeger  
Rules Coordinator

**AMENDATORY SECTION** (Amending WSR 04-02-004, filed 12/24/03, effective 1/1/04)

**WAC 415-111-220 How do I choose a defined contribution rate?** (1) **Contribution rates:** If you are a member of the Teachers' Retirement System (TRS) Plan 3, the School Employees' Retirement System (SERS) Plan 3, or the Public Employees' Retirement System (PERS) Plan 3, you are required to contribute from your compensation according to one of the following rate structures:

	Base Rate	Additional Rate	Total Contribution Rate
<b>Option A</b>			
All ages	5.0%	0.0%	5.0%
<b>Option B</b>			
Up to age 35	5.0%	0.0%	5.0%
Age 35 to 44	5.0%	1.0%	6.0%
Age 45 and above	5.0%	2.5%	7.5%
<b>Option C</b>			
Up to age 35	5.0%	1.0%	6.0%
Age 35 to 44	5.0%	2.5%	7.5%
Age 45 and above	5.0%	3.5%	8.5%
<b>Option D</b>			
All ages	5.0%	2.0%	7.0%
<b>Option E</b>			
All ages	5.0%	5.0%	10.0%
<b>Option F</b>			
All ages	5.0%	10.0%	15.0%

(2) **How do I make the choice?** Under WAC 415-111-110, it is your responsibility to complete the correct form for choosing a contribution rate and submitting the form in a timely manner to your employer as directed on the form.

(3) **Where do I get the form to make my choice?** Your employer must provide the appropriate form to choose a con-

tribution rate if you are enrolling in Plan 3 or transferring from Plan 2 to Plan 3.

(4) **When do I have to choose?** You must choose a contribution rate within ninety calendar days from your date of hire in an eligible position. However, if you are transferring from Plan 2 to Plan 3, you must choose a contribution rate at the same time you transfer. The ninety-day period does not apply to a member transferring from Plan 2 to Plan 3.

(5) **When do contributions begin?**

(a) Once you choose a contribution rate, contributions will begin the first day of the pay cycle in which you make the choice.

(b) If the employer advises the department that you should be reported into Plan 3 membership retroactively, the ninety-day period starts from the date it is discovered that you should have been reported. The department will decide which date to use.

(6) **What if I work for more than one employer?** If you are a Plan 3 member working in eligible positions for more than one employer, you may select a different contribution rate with each employer.

(7) **What happens if I do not make a choice?** Under RCW 41.34.040, you will be assigned a base rate of 5% (Option A) if:

(a) You are a new employee or changing your employer, and do not choose a contribution rate within the ninety-day election period described in subsection (4) of this section; or

(b) You are transferring from Plan 2 to Plan 3 and do not choose a contribution rate at the time of transfer. Contributions required under subsection (a) or (b) will begin the first day of the pay cycle in which you are assigned to Option A.

(8) **Can I change my contribution rate?**

(a) ~~((Except as provided in (e) of this subsection, once you choose a contribution rate or are assigned the base rate of 5% (Option A), you cannot change your contribution rate unless you change employers.))~~ If you are a PERS 3 or SERS 3 member, once you choose a contribution rate or are assigned the base rate of 5% (Option A), you cannot change that contribution rate unless you change employers. This rule is required by an IRS decision on the tax qualified status of PERS 2 and 3 and SERS 2 and 3.

(b) Each time you change employers, you must choose a new contribution rate within ninety days or you will be assigned a base rate of 5% (Option A). No contributions will be taken until you choose a rate or until the ninety-day period has elapsed, whichever occurs first.

(c) Each January, TRS Plan 3 members may change their contribution rate option by providing written notification to their employer as described in WAC 415-111-110(1).

**WSR 05-24-048**  
**PROPOSED RULES**  
**DEPARTMENT OF**  
**RETIREMENT SYSTEMS**

[Filed December 1, 2005, 8:11 a.m.]

Original Notice.

Preproposal statement of inquiry was filed as WSR 05-20-059.

Title of Rule and Other Identifying Information: WAC 415-111-230 Self-directed investment program allocation.

Hearing Location(s): Department of Retirement Systems, 6835 Capitol Boulevard, Conference Room 115, Tumwater, WA, on January 10, 2006, at 1:30 p.m.

Date of Intended Adoption: January 11, 2006.

Submit Written Comments to: Leslie L. Saeger, Rules Coordinator, Department of Retirement Systems, P.O. Box 48380, Olympia, WA 98504-8380, e-mail [leslies@drs.wa.gov](mailto:leslies@drs.wa.gov), fax (360) 753-3166, by 5:00 p.m., on January 10, 2006.

Assistance for Persons with Disabilities: Contact Leslie Saeger, Rules Coordinator, by December 30, 2005, TDD (360) 664-7291, TTY (360) 586-5450, phone (360) 664-7291.

Purpose of the Proposal and Its Anticipated Effects, Including Any Changes in Existing Rules: This amendment clarifies that the department has the right to limit the number of times a Plan 3 member changes investment options, and to impose other restrictions if necessary to protect the performance results of the funds.

Statutory Authority for Adoption: RCW 41.50.050(5).

Statute Being Implemented: Chapter 41.34 RCW.

Rule is not necessitated by federal law, federal or state court decision.

Name of Proponent: Department of Retirement Systems, governmental.

Name of Agency Personnel Responsible for Drafting: Leslie Saeger, P.O. Box 48380, Olympia, WA 98504-8380, (360) 664-7291; Implementation and Enforcement: Dave Nelsen, P.O. Box 48380, Olympia, WA 98504-8380, (360) 664-7291.

No small business economic impact statement has been prepared under chapter 19.85 RCW. These rules have no effect on businesses.

A cost-benefit analysis is not required under RCW 34.05.328. The Department of Retirement Systems is not one of the named departments in RCW 34.05.328.

November 29, 2005

Leslie Saeger

Rules Coordinator

AMENDATORY SECTION (Amending WSR 01-01-059, filed 12/12/00, effective 1/12/01)

**WAC 415-111-230 Self-directed investment program allocation.** This section applies only to members who elect the self-directed investment program pursuant to WAC 415-111-210.

(1) **What is an allocation?** An allocation is a set of instructions ~~((defining which self-directed))~~ identifying your choice of investment program funds ((you wish your money to be invested in)) and the percentage of your money you want to invest in each fund. The amount you allocate to each fund must be designated as a whole percentage ~~((The sum of the percentages that you allocate))~~, and the total must equal one-hundred percent.

Example: Martha has elected the self-directed program as her investment manager and is contributing \$150 per month. Martha decides to invest ~~((into))~~ in three different funds with the following amounts: \$30 invested in fund #1, \$45 invested in fund #2 and \$75 invested in fund #3. To accomplish this she must establish the following allocation:

Allocation to fund #1	20%
Allocation to fund #2	30%
Allocation to fund #3	50%
Total Allocation	100%

(2) **How do I establish an allocation?** You must establish your allocation by contacting the department's designated recordkeeper. Once established, you may change your allocation ~~((at any time by contacting the department's designated recordkeeper))~~ according to the provisions in subsection (5) of this section.

(3) **What happens if I do not ~~((designate))~~ establish an allocation?** If you do not provide an allocation ~~((prior to any of your investment money being received by))~~ before the department's designated recordkeeper begins receiving your investment money, or if you provide an allocation ~~((where))~~ but the sum of the allocated portions does not equal one-hundred percent, your investment money will be ~~((directed into the default fund such that))~~ invested as follows:

(a) If ~~((your))~~ the total ((allocations do not equal)) of the percentages you have allocated is less than one-hundred percent, ~~((+))~~ the department will determine the percentage that is unallocated, and ((+)) ~~((direct))~~ invest the unallocated percentage ~~((into))~~ in the default fund.

Example: Ralph designates the following allocation: 33% fund #1, 33% fund #2, and 33% fund #3. Since the total allocation equals 99%, the unallocated 1% will be ~~((directed into))~~ invested in the default fund.

(b) If the total ~~((allocations exceed))~~ of the percentages you have allocated is greater than one-hundred percent, ~~((the entire allocation))~~ all of your investment money will be ~~((directed into))~~ invested in the default fund.

Example: Chris designates the following allocations: 38% into fund #1, 40% into fund #2, ~~((and))~~ 10% into fund #3, and 15% into fund #4. Since the total allocation equals 103%, all of Chris' investment money will be ~~((directed into))~~ invested in the default fund.

(c) ~~((If no allocation is provided, the entire allocation will be directed into the default fund. Provided, That if the member))~~ If you do not provide an allocation, your money will be invested as follows:

(i) If you previously participated in the self-directed investment program, ~~((the member's))~~ your most recent allocation will be used. However, if ((that)) your allocation includes a fund or funds that are no longer available, the portion of your investment money allocated to the unavailable fund(s) will be ~~((directed into))~~ invested in the default fund.

(ii) If you do not meet the conditions in (c)(i) of this subsection, all of your investment money will be invested in the default fund.

Example: Lew is a new member and elects the self-directed investment program, but does not establish an allocation. All of Lew's investment money will be ~~((directed into))~~ invested in the default fund.

Example: Linda becomes reemployed in an eligible position and elects to participate in the self-directed investment program again, but does not provide an allocation.

Linda previously participated in the self-directed investment program and had the following allocation:

10% in Fund #1

10% in Fund #2

30% in Fund #3

25% in Fund #4

25% in Fund #5

~~((Since))~~ Because she did not establish a new allocation, her previous allocation will be used. However, fund #2 is no longer available, so that ~~((part of her allocation will be directed into))~~ portion of her money will be invested in the default fund. A new allocation will be established for Linda as follows:

10% in Fund #1

10% in Default Fund

30% in Fund #3

25% in Fund #4

25% in Fund #5

(4) **What is the default fund?** The default fund for the self-directed investment program is the Money Market Fund.

(5) ~~((Can))~~ May I change my allocation? Once you have established an allocation or been directed into the default fund, you may change your allocation ~~((at any time))~~ by contacting the department's designated recordkeeper. However, changes must be consistent with any restrictions on trading imposed by the funds involved, and, if necessary to protect the performance results of the investment program funds, the department may:

(a) Limit the number of times you change allocations;

(b) Limit the frequency of the changes;

(c) Limit the manner of making changes; or

(d) Impose other restrictions.

WSR 05-24-049  
PROPOSED RULES  
DEPARTMENT OF  
RETIREMENT SYSTEMS  
[Filed December 1, 2005, 8:13 a.m.]

Original Notice.

Preproposal statement of inquiry was filed as WSR 05-13-046.

Title of Rule and Other Identifying Information: WAC 415-104-111 How is my LEOFF Plan 2 retirement allowance affected if I return to work after retirement?

Hearing Location(s): Department of Retirement Systems, 6835 Capitol Boulevard, Conference Room 115, Tumwater, WA, on January 10, 2006, at 1:30 p.m.

Date of Intended Adoption: January 11, 2006.

Submit Written Comments to: Leslie L. Saeger, Rules Coordinator, Department of Retirement Systems, P.O. Box 48380, Olympia, WA 98504-8380, e-mail [leslies@drs.wa.gov](mailto:leslies@drs.wa.gov), fax (360) 753-3166, by 5:00 p.m., on January 10, 2006.

Assistance for Persons with Disabilities: Contact Leslie Saeger, Rules Coordinator, by December 30, 2005, TDD (360) 664-7291, TTY (360) 586-5450, phone (360) 664-7291.

Purpose of the Proposal and Its Anticipated Effects, Including Any Changes in Existing Rules: This amendment incorporates the provisions of HB 1270. HB 1270 gives law enforcement officers' and fire fighters' retirement system (LEOFF) Plan 2 retirees who return to work in eligible PERS, SERS or TRS positions the option of continuing to receive their LEOFF retirement allowance or joining the other retirement system.

Statutory Authority for Adoption: RCW 41.50.050(5), 41.26.500.

Statute Being Implemented: RCW 41.26.500.

Rule is not necessitated by federal law, federal or state court decision.

Name of Proponent: Department of Retirement Systems, governmental.

Name of Agency Personnel Responsible for Drafting: Leslie Saeger, P.O. Box 48380, Olympia, WA 98504-8380, (360) 664-7291; Implementation and Enforcement: Dave Nelsen, P.O. Box 48380, Olympia, WA 98504-8380, (360) 664-7291.

No small business economic impact statement has been prepared under chapter 19.85 RCW. These rules have no effect on businesses.

A cost-benefit analysis is not required under RCW 34.05.328. The Department of Retirement Systems is not one of the named departments in RCW 34.05.328.

November 29, 2005

Leslie Saeger

Rules Coordinator

AMENDATORY SECTION (Amending WSR 05-12-043, filed 5/25/05, effective 6/25/05)

**WAC 415-104-111 ((How does the department calculate the retirement allowance of a LEOFF Plan 2 member who retires, reenters employment, and then either retires or separates employment again?)) How is my LEOFF Plan 2 retirement allowance affected if I return to work after retirement? ((This rule establishes a method to actuarially recompute your retirement allowance if you are a Plan 2 member who retires, reenters employment causing your retirement allowance to be suspended, and then either retires**

~~or separates employment again.)) This rule applies to you if you are a LEOFF 2 retiree who returns to work in an eligible LEOFF, public employees' retirement system (PERS), school employees' retirement system (SERS), or teachers' retirement system (TRS) position.~~

**(1) If you return to employment in a LEOFF eligible position, you must reenter membership and your retirement allowance will stop.** When you separate from service, the department will calculate your retirement allowance according to this subsection.

(a) If you previously retired before age fifty-three, the department will:

(i) Calculate your retirement allowance pursuant to RCW 41.26.420 using:

(A) Your total years of career service, including service earned prior to your initial retirement and service earned after reentering membership; and

(B) Any increase in your final average salary resulting from your reentry into membership; and

(ii) Actuarially reduce your retirement allowance:

(A) Based on the present value of the retirement allowance payments you received during your initial retirement;

(B) To reflect the difference in the number of years between your current age and the attainment of age fifty-three, if ~~((applicable)) you are not yet fifty-three~~; and

(C) To offset the cost of your benefit option if it includes a survivor feature. See WAC 415-104-215.

(b) If you previously retired at or after age fifty-three, the department will ~~((recompute))~~:

~~(i) Calculate your retirement allowance pursuant to RCW 41.26.420 ((and include any additional service credit you earned)) using:~~

~~(A) Your total years of career service, including service earned prior to your initial retirement and service earned after reentering membership; and~~

~~(B) Any increase in your final average salary resulting from your reentry into membership((-The department will)); and~~

~~(ii) Actuarially reduce your retirement allowance to offset the cost of your benefit option if it includes a survivor feature. See WAC 415-104-215.~~

(c) Under no circumstances will you receive a retirement allowance creditable to a month during which you earned service credit.

**(2) If you enter employment in a PERS, TRS or SERS eligible position, ~~((whether or not you enter PERS, TRS or SERS membership, your LEOFF retirement allowance will be suspended under RCW 41.26.500. Upon separation from such employment, your suspended retirement allowance will be reinstated. In addition, you may choose to have the total monthly retirement payments you would have received had you not reentered employment, plus interest, either:~~**

~~(a) In a lump sum; or~~

~~(b) Actuarially computed in your)) you have two options:~~

~~(a) You may choose not to become a member of the PERS, TRS or SERS retirement system and continue to receive your monthly LEOFF Plan 2 retirement allowance; or~~

~~(b) You may choose to become a member of the PERS, TRS or SERS retirement system. Your LEOFF retirement~~

allowance will be suspended while you earn service credit and make contributions toward another retirement benefit. When you leave the PERS, SERS or TRS eligible position, you will resume receiving your LEOFF retirement allowance, along with retroactive payments for the time you were employed. You may choose to have your retroactive payments in a lump sum or actuarially computed into your LEOFF Plan 2 retirement allowance.

## WSR 05-24-053

### PROPOSED RULES

#### DEPARTMENT OF REVENUE

[Filed December 1, 2005, 1:54 p.m.]

Original Notice.

Preproposal statement of inquiry was filed as WSR 05-20-058.

Title of Rule and Other Identifying Information: Chapter 458-57 WAC, Estate and Transfer Act, amending WAC 458-57-005 Nature of estate tax, definitions, 458-57-015 Valuation of property, property subject to estate tax, how to calculate the tax, 458-57-017 Property subject to generation-skipping transfer tax, how to calculate the tax, allocation of generation-skipping transfer exemption, 458-57-025 Determining the tax liability of nonresidents, 458-57-035 Washington estate tax return to be filed—Penalty for late filing—Interest on late payments—Waiver or cancellation of penalty—Application of payment and 458-57-045 Administration of the tax—Releases, amended returns refunds, heirs of escheat estates; and new sections WAC 458-57-105 Nature of estate tax, definitions, 458-57-115 Valuation of property, property subject to estate tax, how to calculate the tax, 458-57-125 Apportionment of tax when there are out-of-state assets, 458-57-135 Washington estate tax return to be filed—Penalty for late filing—Interest on late payments—Waiver or cancellation of penalty—Application of payment, 458-57-145 Administration of the tax—Releases, amended returns refunds, and statute of limitations, 458-57-155 Farm deduction, and 458-57-165 Escheat estates and absentee distributee (missing heir) property.

Hearing Location(s): Capital Plaza Building, 4th Floor, Large Conference Room, 1025 Union Avenue S.E., Olympia, WA 98504, on January 10, 2006, at 9:30 a.m.

Date of Intended Adoption: January 12, 2006.

Submit Written Comments to: Cindy Evans, P.O. Box 47477, Olympia, WA 98504-7477, e-mail cindyev@dor.wa.gov, fax (360) 570-5524, by January 10, 2006.

Assistance for Persons with Disabilities: Contact Sandy Davis at (360) 725-7499 no later than ten days before the hearing date. Deaf and hard of hearing individuals may call 1-800-451-7985 (TTY users).

Purpose of the Proposal and Its Anticipated Effects, Including Any Changes in Existing Rules: In February 2005, the Washington State Supreme Court ruled in *Hemphill v. State of Washington, Dept. of Rev.*, 153 WA.2d 544, 105 P.3rd 391 (2005) that Washington's estate tax is a pickup tax based on current federal law. The department is proposing to amend the current estate tax rules to reflect the *Hemphill* ruling. The rules will clarify that for deaths occurring on or

before May 16, 2005, the estate tax due to Washington is the amount of state death tax credit available under the current Internal Revenue Code.

New estate tax rules are needed to implement the new Washington estate tax that became effective May 17, 2005, chapters 516 and 514, Laws of 2005. The new rules clarify the nature of the new tax, property subject to the tax, the Washington qualified terminable interest property election, the new method of estate tax apportionment, filing dates, refunds, the new farm deduction, and escheat estates and absentee distributee property.

The proposed changes will improve the ability of department personnel and taxpayers to understand how estate tax applies to individual estates.

Statutory Authority for Adoption: RCW 83.100.047 and 83.100.200.

Statute Being Implemented: Chapter 83.100 RCW.

Rule is necessary because of state court decision, *Hemphill v. State of Washington, Dept. of Rev.*, 153 WA.2d 544, 105 P.3rd 391 (2005).

Name of Proponent: Department of Revenue, governmental.

Name of Agency Personnel Responsible for Drafting: Cindy Evans, 1025 Union Avenue S.E., Suite #544, Olympia, WA, (360) 570-5524; Implementation and Enforcement: Stuart Thronson, 1025 Union Avenue S.E., Suite #544, Olympia, WA, (360) 570-3230.

No small business economic impact statement has been prepared under chapter 19.85 RCW. A small business economic impact statement is not required because the new rules and proposed amendments do not impose any requirements or burdens upon small businesses that are not already required by statute.

A cost-benefit analysis is not required under RCW 34.05.328. These are not significant legislative rules as defined in RCW 34.05.328.

December 1, 2005

Alan R. Lynn

Rules Coordinator

AMENDATORY SECTION (Amending WSR 02-18-078, filed 8/30/02, effective 9/30/02)

**WAC 458-57-005 Nature of estate tax, definitions. (1)**

**Introduction.** This rule describes the nature of Washington state's estate tax as it is imposed by chapter 83.100 RCW (Estate and Transfer Tax Act) for deaths occurring on or before May 16, 2005. The estate tax rules for deaths occurring on or after May 17, 2005, can be found in WAC 458-57-105 through 458-57-165. It also defines terms that will be used throughout chapter 458-57 WAC (Washington Estate and Transfer Tax Reform Act Rules).

(2) **Nature of Washington's estate tax.** The estate tax is neither a property tax nor an inheritance tax. It is a tax imposed on the transfer of the entire taxable estate and not upon any particular legacy, devise, or distributive share.

(a) The state of Washington operates under RCW 83.100.020, which references the Internal Revenue Code (IRC) as it existed **January 1, ((2001)) 2005.** ~~((Federal estate tax law changes enacted after January 1, 2001, do not~~

~~apply to the reporting requirements of Washington's estate tax. For deaths occurring January 1, 2002, and after, Washington has different estate tax reporting requirements than those of the federal government. There will be estates that must file an estate tax return with the state of Washington, even though they are not required to file with the federal government. Washington will continue to collect 100% of the available state death tax credit under the 2001 IRC for all estates that must file a Washington return.))~~ The Washington State Estate and Transfer Tax Return and the instructions for completing the return can be found on the department's web site at <http://www.dor.wa.gov/> under the heading titled forms. The return and instructions can also be obtained by calling the estate tax section at ~~((360-753-5547 or 360-753-7518 or by writing to the following address:~~

~~State of Washington~~

~~Department of Revenue~~

~~Special Programs Division~~

~~P.O. Box 448~~

~~Olympia, WA 98507-0448))~~ 360-570-3265 (option 2).

(b) The estate tax does not apply to completed absolute lifetime transfers. Section 2035(d) of the ~~((2001))~~ Internal Revenue Code generally exempts such transfers. To the extent permitted by this provision, lifetime transfers are not subject to Washington estate tax. The state of Washington does not have a gift tax.

(3) **Definitions.** The following terms and definitions are applicable throughout chapter 458-57 WAC:

(a) "Decedent" means a deceased individual;

(b) "Department" means the department of revenue, the director of that department, or any employee of the department exercising authority lawfully delegated to him by the director;

(c) "Escheat" of an estate means that whenever any person dies, whether a resident of this state or not, leaving property in an estate subject to the jurisdiction of this state and without being survived by any person entitled to that same property under the laws of this state, such estate property shall be designated escheat property and shall be subject to the provisions of RCW 11.08.140 through ~~((11.08.280-))~~ 11.08.300;

(d) "Federal credit" means the maximum amount of the credit for state taxes allowed by section 2011 of the ~~((2001))~~ Internal Revenue Code. This credit is calculated using an "adjusted taxable estate" figure, which is simply the taxable estate, less sixty thousand dollars. However, when the term "federal credit" is used in reference to a generation-skipping transfer (GST), it means the maximum amount of the credit for state taxes allowed by section 2604 of the ~~((2001))~~ Internal Revenue Code;

(e) "Federal return" means any tax return required by chapter 11 (Estate tax) or chapter 13 (Tax on generation-skipping transfers) of the ~~((2001))~~ Internal Revenue Code;

(f) "Federal tax" means tax under chapter 11 (Estate tax) of the ~~((2001))~~ Internal Revenue Code. However, when used in reference to a GST, "federal tax" means the tax under chapter 13 (Tax on generation skipping transfers) of the ~~((2001))~~ Internal Revenue Code;

(g) "Generation-skipping transfer" or "GST" means a "generation-skipping transfer" as defined and used in section 2611 of the ((2004)) Internal Revenue Code;

(h) "Gross estate" means "gross estate" as defined and used in section 2031 of the ((2004)) Internal Revenue Code;

(i) "Internal Revenue Code" or "IRC" means the United States Internal Revenue Code of 1986, as amended or renumbered on January 1, ((2004)) 2005;

(j) "Nonresident" means a decedent who was domiciled outside Washington at the time of death;

(k) "Person" means any individual, estate, trust, receiver, cooperative association, club, corporation, company, firm, partnership, joint venture, syndicate, or other entity and, to the extent permitted by law, any federal, state, or other governmental unit or subdivision or agency, department, or instrumentality thereof;

(l) "Person required to file the federal return" means any person required to file a return required by chapter 11 or 13 of the ((2004)) Internal Revenue Code, such as the personal representative of an estate, a transferor, trustee, or beneficiary of a generation-skipping transfer, or a qualified heir with respect to qualified real property, as defined and used in section 2032A(c) of the ((2004)) Internal Revenue Code;

(m) "Person responsible," means the person responsible for filing the federal and state returns and is the same person described in subsection (l) ((above)) of this section;

(n) "Property," when used in reference to an estate tax transfer, means property included in the gross estate. However, when used in reference to a generation-skipping transfer, "property" means all real and personal property subject to the federal tax;

(o) "Resident" means a decedent who was domiciled in Washington at time of death;

(p) "State return" means the Washington Estate Tax Return required by RCW 83.100.050;

(q) "Transfer" means "transfer" as used in section 2001 of the ((2004)) Internal Revenue Code, or a disposition or cessation of qualified use as defined and used in section 2032A of the ((2004)) Internal Revenue Code; and

(r) "Trust" means "trust" under Washington law and any arrangement described in section 2652 of the ((2004)) Internal Revenue Code.

**AMENDATORY SECTION** (Amending WSR 02-18-078, filed 8/30/02, effective 9/30/02)

**WAC 458-57-015 Valuation of property, property subject to estate tax, how to calculate the tax.** (1) **Introduction.** This rule applies to deaths occurring on or before May 16, 2005, and is intended to help taxpayers determine and pay the correct amount of estate tax with their state return. The estate tax rules for deaths occurring on or after May 17, 2005, can be found in WAC 458-57-105 through 458-57-165. It explains the necessary steps for determining the tax, and provides examples of how the federal estate tax unified credit relates to the amount that must be reported on the state return. (If a nonresident decedent has property located within Washington at the time of death refer to WAC 458-57-025 to determine the amount of tax payable to Washington.)

(2) **Valuation.** The value of every item of property in a decedent's gross estate is its fair market value. However, the personal representative may elect to use the alternate valuation method under section 2032 of the ((2004)) Internal Revenue Code (IRC), and in that case the value is the fair market value at that date, including the adjustments prescribed in that section of the IRC.

The valuation of certain farm property and closely held business property, properly made for federal estate tax purposes pursuant to an election authorized by section 2032A of the ((2004)) IRC, is binding for state estate tax purposes.

(3) **Property subject to estate tax.** The estate tax is imposed on transfers of the taxable estate, as defined in section 2051 of the ((2004)) IRC.

(a) The first step in determining the value of the decedent's taxable estate is to determine the total value of the gross estate. The value of the gross estate includes the value of all the decedent's tangible and intangible property at the time of death. In addition, the gross estate may include property in which the decedent did not have an interest at the time of death. A decedent's gross estate for federal estate tax purposes may therefore be different from the same decedent's estate for local probate purposes. Sections 2031 through 2046 of the ((2004)) IRC provide a detailed explanation of how to determine the value of the gross estate. The following are examples of items that may be included in a decedent's gross estate and not in the probate estate:

(i) Certain property transferred by the decedent during the decedent's lifetime without adequate consideration;

(ii) Property held jointly by the decedent and others;

(iii) Property over which the decedent had a general power of appointment;

(iv) Proceeds of certain policies of insurance on the decedent's life annuities; and

(v) Dower and curtesy of a surviving spouse or a statutory estate in lieu thereof.

(b) The value of the taxable estate is determined by subtracting the authorized exemption and deductions from the value of the gross estate. Under various conditions and limitations, deductions are allowable for expenses, indebtedness, taxes, losses, charitable transfers, and transfers to a surviving spouse. Sections 2051 through 2056A of the ((2004)) IRC provide a detailed explanation of how to determine the value of the taxable estate.

(4) **Imposition of Washington's estate tax.** A tax in an amount equal to the federal credit is imposed by RCW 83.100.030 upon the taxable estate of every decedent. Washington's estate tax is due in every case in which the gross estate tax exceeds the unified credit as specified in section 2010 of the ((2004)) IRC, and there is credit available to be taken, with the exception that all applicable federal estate tax credits are to be applied to the estate's tax liability before the state estate tax liability is computed.

(a) The following tables are taken from the ((2004)) IRC. They show the maximum amount of federal credit available for state death taxes. The amount of federal credit computed multiplied by the appropriate fraction is ((also)) the amount of Washington estate tax due.

Calculate the credit for state death taxes

(i) Step one - calculate the adjusted taxable estate:

Worksheet

Adjusted Taxable Estate

1. Taxable estate (from ~~((Tax Computation, WA Form REV 85-0046))~~ federal form 706, Part 2, Line 3) \$. . . .
2. Adjustment . . . . . \$60,000
3. Adjusted taxable estate. Subtract line 2 from line 1. Use this amount to compute maximum credit for state death taxes in Table ~~((#))~~ (B).

(ii) Step two - apply Table B to the adjusted taxable estate to calculate the credit for state death taxes:

(A)—Taxable estate, equal to or more than...	(B)—and, Taxable estate, less than...	(C)—Base credit on amount in column (A)	(D)—Rate of credit on excess over amount in column (A) (AS A PERCENT)
\$ 0	\$ 40,000	\$ 0	0.0
\$ 40,000	\$ 90,000	\$ 0	0.8
\$ 90,000	\$ 140,000	\$ 400	1.6
\$ 140,000	\$ 240,000	\$ 1,200	2.4
\$ 240,000	\$ 440,000	\$ 3,600	3.2
\$ 440,000	\$ 640,000	\$ 10,000	4.0
\$ 640,000	\$ 840,000	\$ 18,000	4.8
\$ 840,000	\$ 1,040,000	\$ 27,600	5.6
\$ 1,040,000	\$ 1,540,000	\$ 38,800	6.4
\$ 1,540,000	\$ 2,040,000	\$ 70,800	7.2
\$ 2,040,000	\$ 2,540,000	\$ 106,800	8.0
\$ 2,540,000	\$ 3,040,000	\$ 146,800	8.8
\$ 3,040,000	\$ 3,540,000	\$ 190,800	9.6
\$ 3,540,000	\$ 4,040,000	\$ 238,800	10.4
\$ 4,040,000	\$ 5,040,000	\$ 290,800	11.2
\$ 5,040,000	\$ 6,040,000	\$ 402,800	12.0
\$ 6,040,000	\$ 7,040,000	\$ 522,800	12.8
\$ 7,040,000	\$ 8,040,000	\$ 650,800	13.6
\$ 8,040,000	\$ 9,040,000	\$ 786,800	14.4
\$ 9,040,000	\$ 10,040,000	\$ 930,800	15.2
\$ 10,040,000	.....	\$ 1,082,800	16.0

(iii) Step three - multiply the credit for state death taxes by the percentage for the year of the decedent's death:

Year	Percentage
<u>2002</u>	<u>.75</u>
<u>2003</u>	<u>.50</u>
<u>2004</u>	<u>.25</u>
<u>2005</u>	<u>0.00</u>

(b) **Examples.** The following are examples of how the estate tax is applied. These examples should be used only as a general guide. The tax status of other situations must be determined after a review of all of the facts and circumstances.

(i) A married woman dies in the year 2002, leaving her husband and children surviving. Her taxable estate, computed after allowance of the marital deduction, is ~~((\$900,000))~~ \$1,100,000. The adjusted taxable estate is ~~((\$840,000 (\$900,000 - \$60,000)))~~ \$1,040,000 (\$1,100,000 - \$60,000). The Washington state estate tax due is ~~((\$27,600 (the base credit shown in column (C) on the first \$840,000)))~~ \$29,100 (\$38,800 multiplied by .75).

(ii) A married man dies with all of his property passing to his wife, outright under a community property agreement. His marital deduction under section 2056 of the ~~((2001))~~ IRC reduces his federal taxable estate below the applicable exclusion amount. Because his taxable estate is below the applicable exclusion amount, while no Washington estate tax is due a return must be filed.

(iii) The federal taxable estate of a decedent is \$100,000 (before gifts are added, which place the estate into a taxable category). The adjusted taxable estate is \$40,000 for state estate tax purposes (\$100,000 - \$60,000). No Washington estate tax is due because section 2011 of the ~~((2001))~~ IRC provides for no credit unless the adjusted taxable estate exceeds \$40,000. \*Gifts can push an estate into a taxable category.

(iv) A widow dies in 2003, leaving a taxable estate of ~~((\$725,000))~~ \$1,030,000. The amount of tax payable to the state of Washington is computed as follows: Taxable estate of ~~((\$725,000))~~ \$1,030,000 less \$60,000 equals an adjusted taxable estate of ~~((\$665,000))~~ \$970,000. The state death tax credit ~~((2001))~~ IRC section 2011 on the first ~~((\$640,000))~~ \$840,000 is ~~((\$18,000))~~ \$27,600. The state death tax credit for the ~~((\$25,000))~~ \$130,000 increment ~~((\$665,000 - \$640,000))~~ \$970,000 - \$840,000 is ~~((\$1,200))~~ \$7,280 ~~(((4.8% of \$25,000)))~~ 5.6% of \$130,000. The total Washington estate tax liability is ~~((\$19,200 (\$18,000 + \$1,200)))~~ \$17,440 (\$27,600 + \$7,280) x .50 however, the state estate tax cannot exceed the adjusted gross estate tax (line 14) which in this case would be ~~((\$9,250))~~ \$12,300. Therefore, the state estate tax would be ~~((\$9,250))~~ \$12,300 because it is the lower of the two. This occurs in a small window over the applicable exemption threshold amount.

**AMENDATORY SECTION** (Amending WSR 02-18-078, filed 8/30/02, effective 9/30/02)

**WAC 458-57-017 Property subject to generation-skipping transfer tax, how to calculate the tax, allocation of generation-skipping transfer exemption.** (1) **Introduction.** The generation-skipping transfer tax was repealed effective May 17, 2005. If the taxable termination or distribution is the result of a death that occurred on or after May 17, 2005, there is no Washington generation-skipping transfer tax. This repeal does not affect generation-skipping transfer taxable terminations or distributions that result from a death that occurred on or before May 16, 2005. This rule applies only to taxable terminations or distributions that occur as the result of a death that occurred on or before May 16, 2005.

(2) This rule is intended to help taxpayers determine and pay the correct amount of generation-skipping transfer (GST) tax with their state return. It explains what property is subject

to the tax, the calculation of the tax, and the allocation of the generation-skipping transfer exemption.

~~((2))~~ **(3) Property subject to generation-skipping transfer tax.** If real or tangible personal property subject to federal GST tax, as defined and used in section 2611 of the ~~((2001))~~ IRC, is located in this state or if the trust has its principal place of administration in this state at the time of the generation-skipping transfer, a tax in an amount equal to the federal credit provided by section 2604 of the ~~((2001))~~ IRC is imposed on every generation-skipping transfer.

~~((3))~~ **(4) Calculation of the tax.** The allowable Washington credit equals the federal GST tax on the transfer multiplied by 5% (.05). If state GST tax credit was paid to another state(s), the taxpayer must attach evidence of the credit paid to the Washington return. The Washington State Estate and Transfer Tax Return and the instructions for calculating the GST tax can be found on the department's web site at <http://www.dor.wa.gov/> under the heading titled forms. The return and instructions can also be obtained by calling the estate tax section at ~~((360-753-5547 or 360-753-7518 or by writing to the following address:~~

State of Washington  
Department of Revenue  
Special Programs Division  
P.O. Box 448  
Olympia, WA 98507-0448)) 360-570-3265, option 2.

~~((4))~~ **(5) Allocation of generation-skipping transfer exemption.** The allocation(s) of the GST exemption for Washington purposes will be the same as the allocation(s) made for federal GST exemption purposes up to the amount allowed by section 2631 of the ~~((2001))~~ IRC.

AMENDATORY SECTION (Amending WSR 02-18-078, filed 8/30/02, effective 9/30/02)

**WAC 458-57-025 Determining the tax liability of nonresidents.** (1) **Introduction.** This rule applies to deaths occurring on or before May 16, 2005, and discusses how property of nonresident decedents is taxed if that property is located within Washington at the time of death. The estate tax rules for deaths occurring on or after May 17, 2005, can be found in WAC 458-57-105 through 458-57-165.

(2) **Nonresident decedents and Washington's estate tax.** If any decedent has tangible personal property and/or real property located in Washington state at the time of death, that property is subject to Washington's estate tax.

(a) **The reciprocity exemption.** A nonresident decedent's estate is exempt from Washington's estate tax if the nonresident's state of domicile exempts the property of Washington residents from estate, inheritance, or other death taxes normally imposed by the domicile state. The nonresident decedent must have been a citizen and resident of the United States at the time of death. Also, at the time of death the laws of the domicile state must have made specific reference to this state, or must have contained a reciprocal provision under which nonresidents of the domicile state were exempted from applicable death taxes with respect to property or transfers otherwise subject to the jurisdiction of that state.

In those instances where application of this provision results in loss of available federal credit which would otherwise be allowed for federal tax purposes, Washington will absorb that proportional share which is applicable to property within the jurisdiction of this state. Application of this provision will not act to increase the total tax obligation of the estate.

(b) **Property of a nonresident's estate which is located in Washington.** A nonresident decedent's estate may have either real property or tangible personal property located in Washington at the time of death.

(i) All real property physically situated in this state, with the exception of federal trust lands, and all interests in such property, are deemed "located in" Washington. Such interests include, but are not limited to:

- (A) Leasehold interests;
- (B) Mineral interests;

(C) The vendee's (but not the vendor's) interest in an executory contract for the purchase of real property;

(D) Trusts (beneficial interest in trusts of realty); and

(E) Decedent's interest in jointly owned property (e.g., tenants in common, joint with right of survivorship).

(ii) Tangible personal property of a nonresident decedent shall be deemed located in Washington only if:

(A) At the time of death the property is situated in Washington; and

(B) It is present for a purpose other than transiting the state.

(iii) For example, consider a nonresident decedent who was a construction contractor doing business as a sole proprietor. The decedent was constructing a large building in Washington. At the time of death, any of the decedent's equipment that was located at the job site in Washington, such as tools, earthmovers, bulldozers, trucks, etc., would be deemed located in Washington for estate tax purposes. Also, the decedent had negotiated and signed a purchase contract for speculative property in another part of Washington. For estate tax purposes, that real property should also be considered a part of the decedents' estate located in Washington.

(c) **Formula to calculate Washington's estate tax for nonresident decedents.** The amount of tax payable to Washington for a nonresident decedent equals the amount of federal credit multiplied by a fraction, the numerator of which is the value of the property located in Washington, and the denominator of which is the value of the decedent's gross estate. Restated:  $\text{Federal Credit} \times (\text{Gross Value of Property in Washington} / \text{Decedent's Gross Estate}) = \text{Amount of Washington Estate Tax Due}$ . This formula uses the gross value determined for estate tax purposes of any property located in Washington. No reduction will be allowed for any mortgages, liens, or other encumbrances or debts associated with such property except to the extent allowable in computing the gross estate for estate tax purposes.

AMENDATORY SECTION (Amending WSR 02-18-078, filed 8/30/02, effective 9/30/02)

**WAC 458-57-035 Washington estate tax return to be filed—Penalty for late filing—Interest on late payments—Waiver or cancellation of penalty—Application**



**of payment.** (1) **Introduction.** This rule applies to deaths occurring on or before May 16, 2005, and discusses the due date for filing of Washington's estate tax return and payment of the tax due. It explains that a penalty is imposed on the taxes due with the state return when the return is not filed on or before the due date, and that interest is imposed when the tax due is not paid by the due date. The rule also discusses the limited circumstances under which the law allows the department of revenue to cancel or waive the penalty, and the procedure for requesting that cancellation or waiver. The Washington State Estate and Transfer Tax Return and the instructions for completing return can be found on the department's web site at <http://www.dor.wa.gov/> under the heading titled forms. The return and instructions can also be obtained by calling the estate tax section at ((360-753-5547 or 360-753-7518 or by writing to the following address:

State of Washington  
Department of Revenue  
Special Programs Division  
P.O. Box 448

Olympia, WA 98507-0448)) 360-570-3265, option 2.

The estate tax rules for deaths occurring on or after May 17, 2005, can be found in WAC 458-57-105 through 458-57-165.

**(2) Filing the state return—Payment of the tax due.**

The Washington estate tax return (state return) referred to in RCW 83.100.050 and a copy of the federal estate tax return (federal return)~~((, if one must be filed,))~~ and all supporting documentation is due nine months from the date of the decedent's death. The tax due with the state return must be paid on or before the due date.

(a) Section 6075 of the ((2001)) Internal Revenue Code (IRC) requires that the federal return be filed within nine months after the date of the decedent's death. In the case of any estate for which a federal return must be filed under the current IRC, a state return must be filed with the Washington state department of revenue (department) on or before the date on which the federal return is required to be filed. (This may include a federally granted extension of time for filing. See (b) of this subsection ((2)(b)).)

(b) ~~((Extensions to file or extensions for payment of tax for estates that must file a federal estate tax return.~~

~~((i))~~) Section 6081 of the ((2001)) IRC permits the granting of a reasonable extension of time for filing the federal return, generally not to exceed six months from the original due date. If a federal extension of the time to file is granted, the personal representative is required to file a true copy of that extension with the department on or before the original due date, or within thirty days of the issuance of the federal extension, whichever is later. RCW 83.100.050(2). If the personal representative fails to do so, the department may require the personal representative to file the state return on the date that the federal return would have been due had the federal extension not been granted.

~~((ii))~~) (c) When the personal representative obtains an extension of time for payment of the federal tax, or elects to pay that tax in installments, the personal representative may choose to pay the state estate tax over the same time period and in the same manner as the federal tax. The personal representative is required to file a true copy of that extension with the department on or before the original due date, or

within thirty days of the issuance of the federal extension, whichever is later. RCW 83.100.060(2). If the personal representative fails to do so, the department may require the personal representative to pay the state tax on the date that the federal tax would have been due had the federal extension not been granted.

~~((e) Extensions to file for estates that are not required to file a federal estate tax return. For those estates that are not required to file a federal return, the personal representative may request a one-time automatic six-month extension to file. The request must be in writing and acknowledge that interest will begin to accrue from the original due date of the state return. The written request for the extension must be made prior to the date the state return is due.~~

~~(d) Extension to pay tax owed for estates that are not required to file a federal estate tax return. For those estates that are not required to file a federal return, the personal representative may request an extension of time for paying the tax owed when payment of the tax would cause an undue hardship upon the estate or for a payment plan for closely held businesses. The granting of an extension of time to pay the tax owed or for a payment plan for closely held business will not operate to prevent the running of interest. RCW 83.100.070.~~

~~(i) Hardship extensions to pay:~~

~~(A) In any case in which the department finds that payment, on the due date prescribed, or any part of a deficiency would impose undue hardship upon the estate, the department may extend the time for payment for a period or periods not to exceed one year for any one period and for all periods not to exceed four years from the original due date of payment.~~

~~(B) The extension will not be granted upon a general statement of hardship. The term "undue hardship" means more than an inconvenience to the estate. It must appear that a substantial financial loss, for example, due to the sale of property at a sacrifice price, will result to the estate from making payment of the tax owed at the date payment is due. If a market exists, a sale of property at the current market price is not ordinarily considered as resulting in an undue hardship. No extension will be granted if the deficiency is due to negligence or intentional disregard of rules and regulations or to fraud with intent to evade the tax.~~

~~(C) An application for such an extension must be in writing and must contain, or be supported by, information in a written statement declaring that it is made under penalties of perjury showing the undue hardship that would result to the estate if the extension were refused. The application, with the supporting information, must be filed with the department. When received, it will be examined, and, if possible, within thirty days will be denied, granted, or tentatively granted subject to certain conditions of which the personal representative will be notified. The department will not consider an application for such an extension unless it is applied for on or before the due date for payment. If the personal representative desires to obtain an additional extension, it must be applied for on or before the date of the expiration of the previous extension.~~

~~(D) The amount of tax owed for which an extension is granted, along with interest as determined by RCW 83.100.070, shall be paid on or before the expiration of the~~

~~period of extension without the necessity of notice and demand from the department.~~

~~(ii) Payment plans for closely held businesses. The department will abide by the provisions of section 6166 of the 2001 IRC for the granting of payment plans for closely held businesses.~~

~~(e)) (d) The department shall issue a release when Washington's estate tax has been paid. Upon issuance of a release, all property subject to the tax shall be free of any claim for the tax by the state. RCW 83.100.080.~~

**(3) The late filing penalty.** If the state return is not filed by the due date, or any extension of the state return's due date, the person required to file the return may be subject to a late filing penalty.

**(a) When does the penalty apply?** This penalty applies if the person required to file the return has not timely filed the state return with the department prior to being notified by the department, in writing, of the necessity to file the state return. The late payment penalty is equal to five percent of the tax due for each month during which the state return has not been filed, not to exceed the lesser of twenty-five percent of the tax or one thousand five hundred dollars. RCW 83.100.070.

**(b) How is the penalty computed?** The penalty is the equivalent of five percent for each month, but is accrued on a daily basis for those periods less than a month. For any portion of a month, it is calculated by taking the five percent monthly rate and dividing it by the number of days from the beginning of the month through the date the return is filed, including the filing date.

For example, assume a state return is due on February 3rd but is not filed until April 20th of the same year. The state return is delinquent starting with February 4th. The amount of tax due with the state return is \$10,000.

(i) The penalty should be computed as follows:

<del>(Feb 4-Mar 3 \$10,000 tax at 5% per month</del>	<del>\$500.00</del>
<del>Mar 4-Apr 3 \$10,000 tax at 5% per month</del>	<del>\$500.00</del>
<del>Apr 4-Apr 20 \$10,000 tax at .1667% x 17 days</del>	<del>\$283.39</del>
<del>Total delinquent penalty due on April 20th filing date</del>	<del>\$1,283.39</del>

~~(ii) In this example, the first two calendar months are complete and incur the full five percent penalty. The last portion of a month is a total of seventeen days, including both April 4th and April 20th. Since April has thirty days total, the five percent monthly rate is divided by the thirty days in April to arrive at a daily rate of .001667 (or .1667 percent). The daily rate is then multiplied by the seventeen days of penalty accrual to arrive at the total percentage of penalty due for that portion of a month (.001667 x 17 days = .028339 or 2.8339 percent).)~~

<u>Feb 4-Feb 28 \$10,000 tax at 5% per month</u>	<u>\$446.43</u>
<u>Mar 1-Mar 31 \$10,000 tax at 5% per month</u>	<u>\$500.00</u>
<u>Apr 1-Apr 20 \$10,000 tax at .1667% x 17 days</u>	<u>\$333.34</u>
<u>Total delinquent penalty due on April 20th filing date</u>	<u>\$1,297.77</u>

(ii) In this example, the first month (February) is a partial month. February has twenty-eight days, the five percent

monthly rate is divided by twenty-eight days to arrive at a daily rate of .0017857 (or .17857 percent). The daily rate is then multiplied by the twenty-five days of penalty accrual to arrive at the total percentage of penalty due for that portion of a month (.0017857 x 25 days = .044643 or 4.4643 percent). The second calendar month (March) is complete and incurs the full five percent penalty. The last portion of a month is a total of seventeen days, including both April 4th and April 20th. Since April has thirty days total, the five percent monthly rate is divided by the thirty days in April to arrive at a daily rate of .001667 (or .1667 percent). The daily rate is then multiplied by the twenty days of penalty accrual to arrive at the total percentage of penalty due for that portion of a month (.001667 x 20 days = .03334 or 3.334 percent).

**(4) Interest is imposed on late payment.** The department is required by law to impose interest on the tax due with the state return if payment of the tax is not made on or before the due date. RCW 83.100.070. Interest applies to the delinquent tax only, and is calculated from the due date until the date of payment. Interest imposed for periods after December 31, 1996, will be computed at the annual variable interest rate described in RCW 82.32.050(2). Interest imposed for periods prior to January 1, 1997, will be computed at the rate of twelve percent per annum.

**(5) Waiver or cancellation of penalties.** RCW 83.100.070(3) authorizes the department to waive or cancel the penalty for late filing of the state return under limited circumstances.

**(a) Claiming the waiver.** A request for a waiver or cancellation of penalties should contain all pertinent facts and be accompanied by such proof as may be available. The request must be made in the form of a letter and submitted to the department's special programs division. The person responsible bears the burden of establishing that the circumstances were beyond the responsible person's control and directly caused the late filing. The department will cancel or waive the late filing penalty imposed on the state return when the delinquent filing is the result of circumstances beyond the control of the person responsible for filing of the state return. The person responsible for filing the state return is the same person who is responsible for filing the federal return.

**(b) Circumstances eligible for waiver.** In order to qualify for a waiver of penalty the circumstances beyond the control of the person responsible for filing the state return must directly cause the late filing of the return. These circumstances are generally immediate, unexpected, or in the nature of an emergency. Such circumstances result in the person responsible not having reasonable time or opportunity to obtain an extension of their due date (see subsection (2)(b) of this section) or to otherwise timely file the state return. Circumstances beyond the control of the responsible person include, but are not necessarily limited to, the following:

(i) The delinquency was caused by the death or serious illness of the person responsible for filing the state return or a member of the responsible person's immediate family. In order to qualify for penalty waiver, the death or serious illness must directly prevent the person responsible from having reasonable time or opportunity to arrange for timely filing of the state return. Generally, the death or serious illness must have occurred within sixty days prior to the due date, pro-

vided that a valid state return is filed within sixty days of the due date.

(ii) The delinquency was caused by an unexpected and unavoidable absence of the person responsible. Generally, this absence must be within sixty days prior to the due date, provided that a valid state return is filed within sixty days of the due date. "Unavoidable absence of the person responsible" does not include absences because of business trips, vacations, personnel turnover, or personnel terminations.

(iii) The delinquency was caused by the destruction by fire or other casualty of estate records necessary for completion of the state return.

(iv) An estate tax return was timely filed, but was filed incorrectly with another state due to an issue of the decedent's domicile.

(v) A Washington estate tax return was properly prepared and timely filed, but was sent to the location for filing of the federal estate tax return.

(6) **Waiver or cancellation of interest.** Title 83 RCW (Estate Taxation) does not provide any circumstances that allow for waiver of the interest, even though penalty may be waived under limited circumstances (see subsection (5) of this section).

(7) **Application of payment towards liability.** The department will apply taxpayer payments first to interest, next to penalties, and then to the tax, without regard to any direction of the taxpayer.

AMENDATORY SECTION (Amending WSR 02-18-078, filed 8/30/02, effective 9/30/02)

**WAC 458-57-045 Administration of the tax—Releases, amended returns, and refunds(~~—heirs of escheat estates~~).** (1) **Introduction.** This rule applies to deaths occurring on or before May 16, 2005. This rule contains information on releases issued by the department for state estate taxes paid. It explains how and when an amended state return should be filed. ~~((The rule also gives several requirements for notification to the department when a claimed heir to an escheat estate is located.))~~ Information on escheat estates and absentee distributees (missing heirs) can be found at RCW 458-57-165. The estate tax rules for deaths occurring on or after May 17, 2005, can be found in WAC 458-57-105 through 458-57-165.

(2) **Releases.** When the state estate taxes have been paid in full, the department will issue a release to the personal representative upon request. The request will include a completed state return and a copy of the completed federal return, if one was filed. The final determination of the amount of taxes due from the estates that have filed federal returns is contingent on receipt of a copy of the final closing letter issued by the Internal Revenue Service (IRS). The department may require additional information to substantiate information provided by those estates that are not required to file federal returns. The release issued by the department will not bind or estop the department in the event of a misrepresentation of facts.

(3) **Amended returns.** An amended state return must be filed with the department within five days after any amended federal return is filed with the IRS and must be accompanied

by a copy of the amended federal return. ~~((For those estates that are not required to file a federal return, an amended estate tax return must be received within three years from the date the original estate tax return was filed or within two years of paying the tax, whichever is later.))~~

(a) Any time that the amount of federal tax due is adjusted or when there is a final determination of the federal tax due the person responsible must give written notification to the department. This notification must include copies of any final examination report, any compromise agreement, the state tax closing letter, and any other available evidence of the final determination.

(b) If any amendment, adjustment or final determination results in additional state estate tax due, interest will be calculated on the additional tax due at the annual variable interest rate described in RCW 82.32.050(2).

(4) **Refunds.** Only the personal representative or the personal representative's retained counsel may make a claim for a refund of overpaid tax. If the application for refund, with supporting documents, is filed within four months after an adjustment or final determination of tax liability, the department shall pay interest until the date the refund is mailed. If the application for refund, with supporting documents, is filed after four months after the adjustment or final determination, the department shall pay interest only until the end of the four-month period. Any refund issued by the department will include interest at the existing statutory rate defined in RCW 82.32.050(2), computed from the date the overpayment was received by the department until the date it is mailed to the estate's representative. RCW 83.100.130(2).

~~((5) **Heirs of escheat estates.** Heirs to an estate may be located after the estate escheats to Washington. The personal representative of an escheat estate or a claimed heir must provide the department with all information and documentary evidence available that supports the heir's claim. All supporting documents must be in the English language when submitted to the department. The English translation of any foreign document shall be authenticated as reasonably required by the department.~~

~~(a) In all cases where there is a court hearing or the taking of a deposition on the question of a claimed heir, the personal representative shall give the department twenty days' written notice of such hearing or matter.~~

~~(b) The personal representative must give the department at least twenty days' written notice of the hearing on the final account and petition for distribution.~~

~~(c) The department has no statutory authority to pay interest on escheat refunds.))~~

#### NEW SECTION

**WAC 458-57-105 Nature of estate tax, definitions.** (1) **Introduction.** This rule applies to deaths occurring on or after May 17, 2005, and describes the nature of Washington state's estate tax as it is imposed by chapter 83.100 RCW (Estate and Transfer Tax Act). It also defines terms that will be used throughout chapter 458-57 WAC (Washington Estate and Transfer Tax Reform Act rules). The estate tax rule on the nature of estate tax and definitions for deaths occurring on or before May 16, 2005, can be found in WAC 458-57-005.

(2) **Nature of Washington's estate tax.** The estate tax is neither a property tax nor an inheritance tax. It is a tax imposed on the transfer of the entire taxable estate and not upon any particular legacy, devise, or distributive share.

(a) **Relationship of Washington's estate tax to the federal estate tax.** The department administers the estate tax under the legislative enactment of chapter 83.100 RCW, which references the Internal Revenue Code (IRC) as it existed January 1, 2005. Federal estate tax law changes enacted after January 1, 2005, do not apply to the reporting requirements of Washington's estate tax. The department will follow federal Treasury Regulations section 20 (Estate tax regulations), in existence on January 1, 2005, to the extent they do not conflict with the provisions of chapter 83.100 RCW or 458-57 WAC. For deaths occurring January 1, 2009, and after, Washington has different estate tax reporting and filing requirements than the federal government. There will be estates that must file an estate tax return with the state of Washington, even though they are not required to file with the federal government. The Washington state estate and transfer tax return and the instructions for completing the return can be found on the department's web site at <http://www.dor.wa.gov/> under the heading titled forms. The return and instructions can also be requested by calling the department's estate tax section at 360-570-3265, option 2.

(b) **Lifetime transfers.** Washington estate tax taxes lifetime transfers only to the extent included in the federal gross estate. The state of Washington does not have a gift tax.

(3) **Definitions.** The following terms and definitions are applicable throughout chapter 458-57 WAC:

(a) "Absentee distributee" means any person who is the beneficiary of a will or trust who has not been located;

(b) "Decedent" means a deceased individual;

(c) "Department" means the department of revenue, the director of that department, or any employee of the department exercising authority lawfully delegated to him by the director;

(d) "Escheat" of an estate means that whenever any person dies, whether a resident of this state or not, leaving property in an estate subject to the jurisdiction of this state and without being survived by any person entitled to that same property under the laws of this state, such estate property shall be designated escheat property and shall be subject to the provisions of RCW 11.08.140 through 11.08.300;

(e) "Federal return" means any tax return required by chapter 11 (Estate tax) of the Internal Revenue Code;

(f) "Federal tax" means tax under chapter 11 (Estate tax) of the Internal Revenue Code;

(g) "Federal taxable estate" means the taxable estate as determined under chapter 11 of the Internal Revenue Code without regard to:

(i) The termination of the federal estate tax under section 2210 of the IRC or any other provision of law; and

(ii) The deduction for state estate, inheritance, legacy, or succession taxes allowable under section 2058 of the IRC.

(h) "Gross estate" means "gross estate" as defined and used in section 2031 of the Internal Revenue Code;

(i) "Internal Revenue Code" or "IRC" means, for purposes of this chapter, the United States Internal Revenue

Code of 1986, as amended or renumbered on January 1, 2005;

(j) "Person" means any individual, estate, trust, receiver, cooperative association, club, corporation, company, firm, partnership, joint venture, syndicate, or other entity and, to the extent permitted by law, any federal, state, or other governmental unit or subdivision or agency, department, or instrumentality thereof;

(k) "Person required to file the federal return" means any person required to file a return required by chapter 11 of the Internal Revenue Code, such as the personal representative (executor) of an estate;

(l) "Property," when used in reference to an estate tax transfer, means property included in the gross estate;

(m) "Resident" means a decedent who was domiciled in Washington at time of death;

(n) "State return" means the Washington estate tax return required by RCW 83.100.050;

(o) "Taxpayer" means a person upon whom tax is imposed under this chapter, including an estate or a person liable for tax under RCW 83.100.120;

(p) "Transfer" means "transfer" as used in section 2001 of the Internal Revenue Code. However, "transfer" does not include a qualified heir disposing of an interest in property qualifying for a deduction under RCW 83.100.046;

(q) "Washington taxable estate" means the "federal taxable estate":

(i) Less one million five hundred thousand dollars for decedents dying before January 1, 2006, or two million dollars for decedents dying on or after January 1, 2006;

(ii) Less the amount of any deduction allowed under RCW 83.100.046 as a farm deduction;

(iii) Less the amount of the Washington qualified terminable interest property (QTIP) election made under RCW 83.100.047;

(iv) Plus any amount deducted from the federal estate pursuant to IRC § 2056 (b)(7) (the federal QTIP election);

(v) Plus the value of any trust (or portion of a trust) of which the decedent was income beneficiary and for which a Washington QTIP election was previously made pursuant to RCW 83.100.047; and

(vi) Less any amount included in the federal taxable estate pursuant to IRC § 2044 (inclusion of amounts for which a federal QTIP election was previously made).

#### NEW SECTION

**WAC 458-57-115 Valuation of property, property subject to estate tax, and how to calculate the tax. (1) Introduction.** This rule applies to deaths occurring on or after May 17, 2005, and is intended to help taxpayers prepare their return and pay the correct amount of Washington state estate tax. It explains the necessary steps for determining the tax and provides examples of how the tax is calculated. The estate tax rule on valuation of property etc., for deaths occurring on or before May 16, 2005, can be found in WAC 458-57-015.

**(2) Determining the property subject to Washington's estate tax.**

**(a) General valuation information.** The value of every item of property in a decedent's gross estate is its date of death fair market value. However, the personal representative may elect to use the alternate valuation method under section 2032 of the Internal Revenue Code (IRC), and in that case the value is the fair market value at that date, including the adjustments prescribed in that section of the IRC. The valuation of certain farm property and closely held business property, properly made for federal estate tax purposes pursuant to an election authorized by section 2032A of the 2005 IRC, is binding on the estate for state estate tax purposes.

**(b) How is the gross estate determined?** The first step in determining the value of a decedent's Washington taxable estate is to determine the total value of the gross estate. The value of the gross estate includes the value of all the decedent's tangible and intangible property at the time of death. In addition, the gross estate may include property in which the decedent did not have an interest at the time of death. A decedent's gross estate for federal estate tax purposes may therefore be different from the same decedent's estate for local probate purposes. Sections 2031 through 2046 of the IRC

provide a detailed explanation of how to determine the value of the gross estate.

**(c) Deductions from the gross estate.** The value of the federal taxable estate is determined by subtracting the authorized exemption and deductions from the value of the gross estate. Under various conditions and limitations, deductions are allowable for expenses, indebtedness, taxes, losses, charitable transfers, and transfers to a surviving spouse. While sections 2051 through 2056A of the IRC provide a detailed explanation of how to determine the value of the taxable estate the following areas are of special note:

**(i) Funeral expenses.**

(A) Washington is a community property state and under *Estate of Julius C. Lang v. Commissioner*, 97 Fed. 2d 867 (9th Cir. 1938) affirming the reasoning of *Wittwer v. Pember-ton*, 188 Wash. 72, 76, 61 P.2d 993 (1936) funeral expenses reported for a married decedent must be halved. Administrative expenses are not a community debt and are reported at 100%.

**(B) Example.** John, a married man, died in 2005 with an estate valued at \$2.5 million. On Schedule J of the federal estate tax return listed following as expenses:

SCHEDULE J - Funeral Expenses and Expenses Incurred in Administering Property Subject to Claims			
Item Number	Description	Expense Amount	Total Amount
1	<b>A. Funeral expenses:</b> Burial and services	\$4,000	
	(1/2 community debt)	(\$2,000)	
	Total funeral expenses. . . . .		
	<b>B. Administration expenses:</b>		
	1. Executors' commissions - amount estimated/agreed upon paid. (Strike out the words that do not apply). . . . .		\$10,000
	2. Attorney fees - amount estimated/agreed upon/paid. (Strike out the words that do not apply). . . . .		\$5,000

The funeral expenses, as a community debt, were properly reported at 50% and the other administration expenses were properly reported at 100%.

**(ii) Mortgages and liens on real property.** Real property listed on Schedule A should be reported at its fair market value without deduction of mortgages or liens on the property. Mortgages and liens are reported and deducted using Schedule K.

**(iii) Washington qualified terminable interest property (QTIP) election.**

(A) A personal representative may choose to make a larger or smaller percentage or fractional QTIP election on the Washington return than taken on the federal return in order to reduce Washington estate liability while making full use of the federal unified credit.

(B) Section 2056 (b)(7) of the IRC states that a QTIP election is irrevocable once made. Section 2044 states that the value of any property for which a deduction was allowed under section 2056 (b)(7) must be included in the gross estate of the recipient. Similarly, a QTIP election made on the Washington return is irrevocable, and a surviving spouse who receives property for which a Washington QTIP election was

made must include the value of the remaining property in his or her gross estate for Washington estate tax purposes.

(C) The Washington QTIP election must adequately identify the assets, by schedule and item number, included as part of the election, either on the return or, if those assets have not been determined when the estate tax return is filed, on a statement to that effect, prepared when the assets are definitively identified. This statement may be filed with the department at that time or when the surviving spouse's estate tax return is filed.

**(D) Example.** A decedent dies in 2009 with a gross estate of \$5 million. The decedent established a QTIP trust for the benefit of her surviving spouse in an amount to result in no federal estate tax. The federal unified credit is \$3.5 million for the year 2009. In 2009 the Washington statutory deduction is \$2 million. To pay no Washington estate tax the personal representative of the estate has the option of electing a larger percentage or fractional QTIP election resulting in the maximization of the individual federal unified credit and paying no tax for Washington purposes.

The federal estate tax return reflected the QTIP election with a percentage value to pay no federal estate tax. On the Washington return the personal representative elected QTIP

treatment on a percentage basis in an amount so no Washington estate tax is due. Upon the surviving spouse's death the assets remaining in the QTIP trust must be included in the surviving spouse's gross estate.

(d) **Washington taxable estate.** The estate tax is imposed on the "Washington taxable estate." The "Washington taxable estate" means the "federal taxable estate":

(i) Less one million five hundred thousand dollars for decedents dying before January 1, 2006, or two million dollars for decedents dying on or after January 1, 2006;

(ii) Less the amount of any deduction allowed under RCW 83.100.046 as a farm deduction;

(iii) Less the amount of the Washington qualified terminable interest property (QTIP) election made under RCW 83.100.047;

(iv) Plus any amount deducted from the federal estate pursuant to IRC § 2056 (b)(7) (the federal QTIP election);

(v) Plus the value of any trust (or portion of a trust) of which the decedent was income beneficiary and for which a Washington QTIP election was previously made pursuant to RCW 83.100.047; and

(vi) Less any amount included in the federal taxable estate pursuant to IRC § 2044 (inclusion of amounts for which a federal QTIP election was previously made).

(e) **Federal taxable estate.** The "federal taxable estate" means the taxable estate as determined under chapter 11 of the IRC without regard to:

(i) The termination of the federal estate tax under section 2210 of the IRC or any other provision of law; and

(ii) The deduction for state estate, inheritance, legacy, or succession taxes allowable under section 2058 of the IRC.

**(3) Calculation of Washington's estate tax.**

(a) The tax is calculated by applying Table W to the Washington taxable estate. See (d) of this subsection for the definition of "Washington taxable estate."

**Table W**

Washington Taxable Estate is at Least	But Less Than	The Amount of Tax Equals Initial Tax Amount	Plus Tax Rate %	Of Washington Taxable Estate Value Greater Than
\$0	\$1,000,000	\$0	10.00%	\$0
\$1,000,000	\$2,000,000	\$100,000	14.00%	\$1,000,000
\$2,000,000	\$3,000,000	\$240,000	15.00%	\$2,000,000
\$3,000,000	\$4,000,000	\$390,000	16.00%	\$3,000,000
\$4,000,000	\$6,000,000	\$550,000	17.00%	\$4,000,000
\$6,000,000	\$7,000,000	\$890,000	18.00%	\$6,000,000
\$7,000,000	\$9,000,000	\$1,070,000	18.50%	\$7,000,000
\$9,000,000		\$1,440,000	19.00%	\$9,000,000

**(b) Examples.**

(i) A widow dies on September 25, 2005, leaving a gross estate of \$2.1 million. The estate had \$100,000 in expenses deductible for federal estate tax purposes. Examples of allowable expenses include funeral expenses, indebtedness, property taxes, and charitable transfers. The Washington taxable estate equals \$500,000.

Gross estate	\$2,100,000
Less allowable expenses deduction	- \$100,000
Less \$1,500,000 statutory deduction	<u>- \$1,500,000</u>
Washington taxable estate	\$500,000

Based on Table W, the estate tax equals \$50,000 (\$500,000 x 10% Washington estate tax rate).

(ii) John dies on October 13, 2005, with an estate valued at \$3 million. John left \$1.5 million to his spouse, Jane, using the unlimited marital deduction. There is no Washington estate tax due on John's estate.

Gross estate	\$3,000,000
Less unlimited marital deduction	- \$1,500,000
Less \$1,500,000 statutory deduction	<u>- \$1,500,000</u>
Washington taxable estate	\$0

Although Washington estate tax is not due, the estate is still required to file a Washington estate tax return along with a photocopy of the filed and signed federal return and all supporting documentation.

NEW SECTION

**WAC 458-57-125 Apportionment of tax when there are out-of-state assets. (1) Introduction.** This rule applies to deaths occurring on or after May 17, 2005, and discusses how to apportion the estate tax when there is out-of-state property included in the gross estate. The estate tax rule on apportionment of estate tax for deaths occurring on or before May 16, 2005, can be found in WAC 458-57-025.

**(2) Calculation of apportioned tax.** Apportionment is allowed for estate property located outside of Washington. The amount of tax is determined using Table W (see WAC 458-57-115) multiplied by a fraction. The numerator of the fraction is the value of the property located in Washington. The denominator of the fraction is the value of the decedent's gross estate. Property qualifying for the farm deduction is excluded from the numerator and denominator of the fraction. See WAC 458-57-155 (Farm deduction) for additional information on the farm deduction.

**(3) Example.** A widow dies in 2006 leaving a gross estate of \$3.1 million. The estate had \$100,000 in expenses

deductible for federal estate tax purposes. The decedent also owned a home in Arizona valued at \$300,000.

Gross estate	\$3,100,000
Less allowable expenses deduction	- \$100,000
Less \$2,000,000 statutory deduction	- \$2,000,000
	\$1,000,000
Washington taxable estate	\$1,000,000

$$(\$2,800,000 (\$3,100,000 - \$300,000) / \$3,100,000) \times \$100,000 = \$90,323$$

The estate does not have to pay estate tax to the state of Arizona in order to reduce the tax owed to Washington. The estate tax due to Washington is \$90,323.

(4) **When is property located in Washington?** A decedent's estate may have either real property or tangible personal property located in Washington at the time of death.

(a) All real property physically situated in this state, with the exception of federal trust lands, and all interests in such property, are deemed "located in" Washington. Such interests include, but are not limited to:

- (i) Leasehold interests;
- (ii) Mineral interests;
- (iii) The vendee's (but not the vendor's) interest in an executory contract for the purchase of real property;
- (iv) Trusts (beneficial interest in trusts of realty); and
- (v) Decedent's interest in jointly owned property (e.g., tenets in common, joint with right of survivorship).

(b) Tangible personal property of a nonresident decedent shall be deemed located in Washington only if:

- (i) At the time of death the property is situated in Washington; and
- (ii) It is present for a purpose other than transiting the state.

(c) **Example.** A nonresident decedent was a construction contractor doing business as a sole proprietor. The decedent was constructing a large building in Washington. At the time of death, any of the decedent's equipment that was located at the job site in Washington, such as tools, earthmovers, bulldozers, trucks, etc., would be deemed located in Washington for estate tax purposes. Also, the decedent had negotiated and signed a purchase contract for speculative property in another part of Washington. For estate tax purposes, that real property should also be considered a part of the decedent's estate located in Washington.

#### NEW SECTION

**WAC 458-57-135 Washington estate tax return to be filed—Penalty for late filing—Interest on late payments—Waiver or cancellation of penalty—Application of payment.** (1) **Introduction.** This rule applies to deaths occurring on or after May 17, 2005, and discusses the due date for filing of Washington's estate tax return and payment of the tax due. It explains that a penalty is imposed on the taxes due with the state return when the return is not filed on or before the due date, and that interest is imposed when the tax due is not paid by the due date. The rule also discusses the limited circumstances under which the law allows the department of revenue to cancel or waive the penalty, and the

Based on the tax table, the estate tax equals \$100,000 (\$1,000,000 x 10% Washington estate tax rate). Because the decedent owned an out-of-state asset, the tax due to Washington is prorated by multiplying the amount of tax owed by a fraction. The numerator of the fraction is the value of the property located in Washington divided by the denominator that equals the value of the decedent's gross estate. The fraction is then multiplied by the amount of tax.

procedure for requesting that cancellation or waiver. The estate tax rule on the estate tax return etc., for deaths occurring on or before May 16, 2005, can be found in WAC 458-57-035.

(2) **Estate tax return.** The Washington state estate and transfer tax return and the instructions for completing return can be found on the department's web site at <http://www.dor.wa.gov/> under the heading titled forms. The return and instructions can also be obtained by calling the estate tax section at 360-570-3265, option 2.

#### (3) **Filing the state return—Payment of the tax due.**

(a) The Washington estate tax return (state return) referred to in RCW 83.100.050 is due nine months after the date of the decedent's death. The following is the list of documents that must accompany the state return:

- (i) A copy of the filed Federal Form 706 United States Estate (and Generation-skipping Transfer), 706NA, or 706QDT Tax Return(s), signed by the person required to file;
- (ii) All supporting documentation for completed federal return schedules;
- (iii) If applicable, a copy of an approved Form 4768 Application for Extension of Time to File a Return and/or Pay U.S. Estate (and Generation-skipping Transfer) Taxes;
- (iv) Copy(ies) of any Washington schedules that differ from the federal form schedules, along with supporting documentation;
- (v) Photocopy of death certificate;
- (vi) Photocopy of letters of administration, if any;
- (vii) Copy of the will and trust(s), if any;
- (viii) Copy of other state estate or inheritance return(s) and proof of payment(s), if any; and
- (ix) Payment, if tax is due.

The tax due with the state return must be paid on or before the due date.

(b) In any case where a federal return must be filed under the current Internal Revenue Code (IRC), a state return must be filed with the Washington state department of revenue (department) on or before the date that the federal return is required to be filed. (This may include a federally granted extension of time for filing. See subsection (2)(b).) Section 6075 of the IRC requires that the federal return be filed within nine months after the date of the decedent's death.

#### (c) **Extensions to file or extensions for payment of tax.**

(i) Section 6081 of the IRC permits the granting of a reasonable extension of time for filing the federal return, generally not to exceed six months from the original due date. If a federal extension of the time to file is granted, the personal representative is required to file a true copy of that extension or installment approval with the department on or before the

original due date, or within thirty days of the issuance of the federal extension or installment approval, whichever is later. RCW 83.100.050(2). If the personal representative fails to do so, the department may require the personal representative to file the state return on the date that the federal return would have been due had the federal extension not been granted.

(ii) When the personal representative obtains an extension of time for payment of the federal tax, or elects to pay that tax in installments, the personal representative may choose to pay the state estate tax over the same time period and in the same manner as the federal tax. The personal representative is required to file a true copy of that extension with the department on or before the original due date, or within thirty days of the issuance of the federal extension, whichever is later. RCW 83.100.060(2). If the personal representative fails to do so, the department may require the personal representative to pay the state tax on the date that the federal tax would have been due had the federal extension not been granted.

(4) **The late filing penalty.** If the state return is not filed by the due date, or any extension of the state return's due date, the person required to file the return may be subject to a late filing penalty.

(a) **When does the penalty apply?** Penalty applies if the person required to file the return has not timely filed the state return with the department prior to being notified by the department, in writing, of the necessity to file the state return. The late payment penalty is equal to five percent of the tax due for each month during which the state return has not been filed, not to exceed the lesser of twenty-five percent of the tax or one thousand five hundred dollars. RCW 83.100.070.

(b) **How is the penalty computed?** The penalty is the equivalent of five percent for each month, but is accrued on a daily basis for those periods less than a month. For any portion of a month, it is calculated by taking the five percent monthly rate and dividing it by the number of days from the beginning of the month through the date the return is filed, including the filing date.

For example, a state return is due on February 3rd but is not filed until April 20th of the same year. The state return is delinquent starting with February 4th. The amount of tax due with the state return is \$10,000.

(i) The penalty is computed as follows:

Feb 4-Feb 28	\$10,000 tax at 5% per month	\$446.43
Mar 1-Mar 31	\$10,000 tax at 5% per month	\$500.00
Apr 1-Apr 20	\$10,000 tax at .1667% x 20 days	\$333.34
Total delinquent penalty due on April 20th filing date		\$1,297.77

(ii) In this example, the first month (February) is a partial month. February has twenty-eight days, the five percent monthly rate is divided by twenty-eight days to arrive at a daily rate of .0017857 (or .17857 percent). The daily rate is then multiplied by the twenty-five days of penalty accrual to arrive at the total percentage of penalty due for that portion of a month (.0017857 x 25 days = .044643 or 4.4643 percent). The second calendar month (March) is complete and incurs the full five percent penalty. The last portion of a month is a total of seventeen days, including both April 4th and April

20th. Since April has thirty days total, the five percent monthly rate is divided by the thirty days in April to arrive at a daily rate of .001667 (or .1667 percent). The daily rate is then multiplied by the twenty days of penalty accrual to arrive at the total percentage of penalty due for that portion of a month (.001667 x 20 days = .03334 or 3.334 percent).

(5) **Interest is imposed on late payment.** The department is required by law to impose interest on the tax due with the state return if payment of the tax is not made on or before the due date. RCW 83.100.070. Interest applies to the delinquent tax only, and is calculated from the due date until the date of payment. Interest imposed for periods after December 31, 1996, will be computed at the annual variable interest rate described in RCW 82.32.050(2). Interest imposed for periods prior to January 1, 1997, will be computed at the rate of twelve percent per annum.

(6) **Waiver or cancellation of penalties.** RCW 83.100.070(3) authorizes the department to waive or cancel the penalty for late filing of the state return under limited circumstances.

(a) **Claiming the waiver.** A request for a waiver or cancellation of penalties should contain all pertinent facts and be accompanied by such proof as may be available. The request must be made in the form of a letter and submitted to the department's special programs division. The person responsible bears the burden of establishing that the circumstances were beyond their control and directly caused the late filing. The department will cancel or waive the late filing penalty imposed on the state return when the delinquent filing is the result of circumstances beyond the control of the person responsible for filing of the state return. The person responsible for filing the state return is the same person who is responsible for filing the federal return.

(b) **Circumstances eligible for waiver.** In order to qualify for a waiver of penalty the circumstances beyond the control of the person responsible for filing the state return must directly cause the late filing of the return. These circumstances are generally immediate, unexpected, or in the nature of an emergency. Such circumstances result in the person not having reasonable time or opportunity to obtain an extension of their due date (see subsection (2)(b)) or to otherwise timely file the state return. Circumstances beyond the control include, but are not necessarily limited to, the following:

(i) The delinquency was caused by the death or serious illness of the person responsible for filing the state return or a member of the immediate family. In order to qualify for penalty waiver, the death or serious illness must directly prevent them from having reasonable time or opportunity to arrange for timely filing of the state return. Generally, the death or serious illness must have occurred within sixty days prior to the due date, provided that a valid state return is filed within sixty days of the due date.

(ii) The delinquency was caused by an unexpected and unavoidable absence of the person responsible. Generally, this absence must be within sixty days prior to the due date, provided that a valid state return is filed within sixty days of the due date. "Unavoidable absence of the person responsible" does not include absences because of business trips, vacations, personnel turnover, or personnel terminations.



(iii) The delinquency was caused by the destruction by fire or other casualty of estate records necessary for completion of the state return.

(iv) An estate tax return was timely filed, but was filed incorrectly with another state due to an issue of the decedent's domicile.

(v) A Washington estate tax return was properly prepared and timely filed, but was sent to the location for filing of the federal estate tax return.

(7) **Waiver or cancellation of interest.** Title 83 RCW (Estate taxation) does not provide any circumstances that allow for waiver of the interest, even though penalty may be waived under limited circumstances (see subsection (6) of this section).

(8) **Application of payment towards liability.** The department will apply taxpayer payments first to interest, next to penalties, and then to the tax, without regard to any direction of the taxpayer.

#### NEW SECTION

**WAC 458-57-145 Administration of the tax—Releases, amended returns, refunds, and statute of limitations.** (1) **Introduction.** This rule applies to deaths occurring on or after May 17, 2005, and contains information on releases issued by the department for state estate taxes paid. It explains how and when an amended state return should be filed and information on refunds and statute of limitations. The estate tax rule on releases, amended returns etc., for deaths occurring on or before May 16, 2005, can be found in WAC 458-57-045.

(2) **Releases.** When the state estate taxes have been paid in full, the department will issue a release to the personal representative. The final determination of the amount of taxes due from the estates that have filed federal returns is contingent upon receipt of a copy of the final closing letter issued by the Internal Revenue Service (IRS). The department may require additional information to substantiate information provided by those estates that are not required to file federal returns. The release issued by the department will not bind or estop the department in the event of a misrepresentation of facts.

(3) **Amended returns.** An amended state return must be filed with the department within five days of amending a federal return with the IRS and must be accompanied by a copy of the amended federal return. For those estates that are not required to file a federal return, an amended estate tax return must be received within three years from the date the original estate tax return was filed or within two years of paying the tax, whichever is later.

(a) Any time that the amount of federal tax due is adjusted or when there is a final determination of the federal tax due, the person responsible for filing must give written notification to the department. This notification must include copies of any final examination report, any compromise agreement, the state tax closing letter, and any other available evidence of the final determination.

(b) If any amendment, adjustment or final determination results in additional state estate tax due, interest will be calcu-

lated on the additional tax due at the annual variable interest rate described in RCW 82.32.050.

(4) **Refunds.** Only the personal representative or the personal representative's retained counsel may make a claim for a refund of overpaid tax. If the application for refund, with supporting documents, is filed within four months after an adjustment or final determination of tax liability, the department shall pay interest until the date the refund is mailed. If the application for refund, with supporting documents, is filed after four months after the adjustment or final determination, the department shall pay interest only until the end of the four-month period. Any refund issued by the department will include interest at the existing statutory rate defined in RCW 82.32.050, computed from the date the overpayment was received by the department until the date it is mailed to the estate's representative. RCW 83.100.130.

#### (5) **Statute of limitations.**

(a) No assessment or correction of an assessment for additional taxes, penalties, or interest due may be made by the department more than four years after the close of the calendar year in which a Washington return is due under this chapter, including any extension of time for filing, except upon a showing of fraud or of misrepresentation of a material fact by the taxpayer.

(b) For persons liable for tax under RCW 83.100.120, the period for assessment or correction of an assessment extend an additional three years beyond the period described in (a) of this subsection.

(c) A taxpayer may extend the periods of limitation under (a) or (b) of this subsection by executing a written waiver. The execution of the waiver shall also extend the period for making a refund as provided in RCW 83.100.130.

#### NEW SECTION

**WAC 458-57-155 Farm deduction.** (1) **Introduction.** This rule applies to deaths occurring on or after May 17, 2005, and is intended to help taxpayers determine if the estate is eligible for the farm deduction and to correctly calculate the deduction.

(2) **Definitions.** The following terms and definitions are applicable throughout chapter 458-57 WAC:

(a) "Active management" means the making of the management decisions of a farm, other than the daily operating decisions;

(b) "Farm" includes stock, dairy, poultry, fruit, furbearing animal, and truck farms; plantation; ranches; nurseries; ranges; greenhouses or other similar structures used primarily for the raising of agricultural or horticultural commodities; and orchards and woodlands;

(c) "Farming purposes" means:

(i) Cultivating the soil or raising or harvesting any agricultural or horticultural commodity, including the raising, shearing, feeding, caring for, training, and management of animals on a farm;

(ii) Handling, drying, packing, grading, or storing on a farm any agricultural or horticultural commodity in its unmanufactured state, but only if the owner, tenant, or operator of the farm regularly produces more than one-half of the commodity so treated; and

(iii)(A) The planting, cultivating, caring for, or cutting of trees; or

(B) The preparation, other than milling, of trees for market.

(d) "Member of the family" means, with respect to any individual, only:

(i) An ancestor of the individual;

(ii) Spouse of the individual;

(iii) A lineal descendant of the individual; of the individual's spouse, or a parent of the individual; or

(iv) The spouse of any lineal descendant described in (d)(iii) of this subsection.

A legally adopted child of an individual shall be treated as the child of such individual by blood.

(e) "Qualified heir" means, with respect to any property, a member of the decedent's family who acquired property, or to whom property passed, from the decedent.

(f)(i) "Qualified real property" means real property which was acquired from or passed from the decedent to a qualified heir of the decedent and which, on the date of the decedent's death, was being used for a qualified use by the decedent or a member of the decedent's family, but only if:

(A) Fifty percent or more of the adjusted value of the gross estate consists of the adjusted value of real or personal property which:

(I) On the date of the decedent's death, was being used for a qualified use by the decedent or a member of the decedent's family; and

(II) Was acquired from or passed from the decedent to a qualified heir of the decedent;

(B) Twenty-five percent or more of the adjusted value of the gross estate consists of the adjusted value of real property which meets the requirements of (f)(i)(A)(II) and (C) of this subsection; and

(C) During the eight-year period ending on the date of the decedent's death there have been periods aggregating five years or more during which:

(I) The real property was owned by the decedent or a member of the decedent's family and used for a qualified use by the decedent or a member of the decedent's family; and

(II) There was material participation by the decedent or a member of the decedent's family in the operation of the farm. For the purposes of this subsection (f)(i)(C)(II), material participation shall be determined in a manner similar to the manner used for purposes of section 1402 (a)(1) of the Internal Revenue Code (IRC).

(ii) For the purposes of this subsection, the term "adjusted value" means:

(A) In the case of the gross estate, the value of the gross estate, determined without regard to any special valuation under section 3032A of the IRC, reduced by any amounts allowable as a deduction under section 2053 (a)(4) of the IRC; or

(B) In the case of any real or personal property, the value of the property for purposes of chapter 11 of the IRC, determined without regard to any special valuation under section 2032A of the IRC, reduced by an amount allowable as a deduction in respect of such property under section 2053 (a)(4) of the IRC.

(g) "Qualified use" means the property is used as a farm for farming purposes. In the case of real property which meets the requirements of (f)(i)(C) of this subsection, residential buildings and related improvements on the real property occupied on a regular basis by the owner or lessee for the purpose of operating or maintaining the real property, and roads, buildings, and other structures and improvements functionally related to the qualified use shall be treated as real property devoted to the qualified use. For tangible personal property eligible for a deduction under subsection (1)(b) of this section, "qualified use" means the property is used primarily for farming purposes on a farm.

(h) "Qualified woodland" means any real property which:

(i) Is used in timber operations; and

(ii) Is an identifiable area of land such as an acre or other area for which records are normally maintained in conducting timber operations.

(i) "Timber operations" means:

(i) The planting, cultivating, caring for, or cutting of trees; or

(ii) The preparation, other than milling, of trees for market.

**(3) Farm deduction—Qualification criteria.**

(a) A deduction from the Washington taxable estate is available for the value of qualified real property and the value of any tangible personal property used by the decedent or a member of the decedent's family for a qualified use. In certain circumstances an estate of a tenant farmer may deduct the value of agricultural personal property. See subsection (7) of this section. If the estate is eligible for the federal special valuation of farmland it would also be eligible for the state deduction. The estate does not have to elect special valuation treatment for federal purposes in order to take the state deduction. Unlike the federal special valuation for farmland there is no requirement that the heir to the land and equipment continue farming.

(b) There are several criteria that must be met before the deduction can be taken:

(i) Decedent at the time of his or her death was a citizen or resident of the United States;

(ii) Fifty percent or more of the estate's adjusted value must be in agricultural real and personal property;

(iii) On the date of the decedent's death the real and personal property must have been used for a qualified use (farming) by the decedent or a member of the decedent's family;

(iv) The real and personal property must pass from the decedent to a qualified heir; and

(v) Twenty-five percent or more of the estate consists of agricultural real property (land) that was actively managed by the decedent or the decedent's family.

**(4) What does "acquired from the decedent" mean?**

Property shall be considered to have been acquired from or to have passed from the decedent if:

(a) The property is so considered under section 1014(b) of the IRC;

(b) The property is acquired by any person from the estate; or

(c) The property is acquired by any person from a trust, to the extent the property is includible in the gross estate of the decedent.

(5) **Treatment of qualified real property held as a community property.** If the decedent and the decedent's surviving spouse at any time held qualified real property as community property, the interest of the surviving spouse in the property shall be taken into account under this section.

(6) **Value of trees growing on woodlands.** In the case of qualified woodland, the value of trees growing on the woodland may be deducted if otherwise qualified under this section.

(7) **Tenant farmers.** If the following criteria are met, the estate of a tenant farmer may deduct from the Washington taxable estate the value of the agricultural personal property:

(a) Decedent at the time of his or her death was a citizen or resident of the United States;

(b) Fifty percent or more of the estate adjusted value must be in agricultural personal property;

(c) On the date of the decedent's death the personal property must have been used for a qualified use (farming) by the decedent or a member of the decedent's family; and

(d) The personal property must pass from the decedent to a qualified heir.

**(8) Examples.**

(a) The decedent died May 18, 2005, with a federal taxable estate valued at \$4 million. The decedent was a dry land wheat farmer and owned 2000 acres of land valued at \$2 million (\$1,000 per acre) and \$500,000 in farm equipment. The decedent was a U.S. citizen, owned and worked the acreage for the last twenty years, and left the farm to his son, a qualified heir. The value of the farm acreage and equipment exceeds the required 50% or more of the gross estate ( $\$2,000,000 + \$500,000 > \$4,000,000 \times 50\%$ ). The value of the 2000 acres and the farm equipment can be deducted from the decedent's gross estate. In this example estate tax is not due. The calculations are shown below:

Federal taxable estate	\$4,000,000
Less \$2,500,000 farm deduction	- \$2,500,000
Less \$1,500,000 statutory exemption	- \$1,500,000
	<hr/>
Washington taxable estate	\$0

Although Washington estate tax is not due, the estate is still required to file a Washington estate tax return along with a photocopy of the filed and signed federal return and all supporting documentation.

(b) The decedent died August 28, 2005, with a federal taxable estate valued at \$5 million. The decedent was a hay farmer and owned 600 acres of land valued at \$1.8 million (\$3,000 per acre) and \$500,000 in farm equipment. The decedent was a U.S. citizen, owned and worked the acreage for the last twenty years, and left the farm to his son, a qualified heir. The value of the farm acreage and equipment did not meet the required 50% or more of the gross estate, therefore, the estate cannot deduct the value of the farm and farm equipment ( $\$1,800,000 + \$500,000 < \$5,000,000 \times 50\%$ ). Here are the calculations:

Federal taxable estate	\$4,000,000
Less \$1,500,000 statutory exemption	- \$1,500,000
	<hr/>
Washington taxable estate	\$3,500,000

Based on the tax table, the estate owes \$470,000 in Washington estate tax.

(c) The decedent died May 23, 2005, with a federal taxable estate valued at \$1.6 million. The decedent was a tenant hay farmer that owned \$400,000 of hay in storage that had been harvested but not sold and \$800,000 in farm equipment. The decedent was a U.S. citizen, used the farm equipment in a qualified use for the last six years, and left the equipment to his son-in-law, a qualified heir. The value of the farm equipment met the required 50% or more of the gross estate so it can be deducted from the decedent's gross estate ( $\$800,000 = \$1,600,000 \times 50\%$ ). In this example no estate tax is due. The calculations are shown below:

Federal taxable estate	\$1,600,000
Less \$800,000 farm deduction	- \$800,000
Less \$1,500,000 statutory exemption	- \$1,500,000
	<hr/>
Washington taxable estate	\$0

Although Washington estate tax is not due, the estate is still required to file a Washington estate tax return along with a photocopy of the filed and signed federal return and all supporting documentation.

(d) The decedent died April 7, 2006, with a federal taxable estate valued at \$2.5 million. The decedent owned 100 acres of timberland valued at \$100,000 (\$1,000 per acre), timber valued at \$800,000 (\$80,000 per acre), 200 acres of pasture land valued at \$500,000 (\$2,500 per acre) and \$50,000 in farm equipment. The decedent was a U.S. citizen, owned and worked the acreage for the last ten years, and left the timber and farm land to his daughter, a qualified heir. The value of the timberland and farm acreage and equipment exceeded the required 50% or more of the gross estate therefore the estate can deduct the value of the timber and farm land and farm equipment ( $\$100,000 + \$800,000 + \$500,000 + \$50,000 > \$2,500,000 \times 50\%$ ). The calculations are shown below:

Federal taxable estate	\$2,500,000
Less \$1,450,000 farm deduction	- \$1,450,000
Less \$2,000,000 statutory exemption	- \$2,000,000
	<hr/>
Washington taxable estate	\$0

Although Washington estate tax is not due, the estate is still required to file a Washington estate tax return along with a photocopy of the filed and signed federal return and all supporting documentation.

NEW SECTION

**WAC 458-57-165 Escheat estates and absentee distributee (missing heir) property. (1) Introduction.** This

rule explains the notification requirements to the department and other procedural information for potential escheat estates and the procedures for reporting absentee distributee property.

**(2) Escheat estates.**

(a) Escheat of an estate means that a person dies, whether a resident of this state or not, leaving property subject to the jurisdiction of this state without being survived by any person entitled to the property under RCW 11.04.015 (descent and distribution) and the property reverts to the state.

(b) **Notification to the department of a potential escheat estate.** The department must be promptly notified in writing of the potential escheat on revenue form 85 0030-1 Notice of Escheat Property when a decedent dies without a will and has no known intestate heirs. This form can be found on the department's web site at <http://dor.wa.gov/> under the tab titled forms. The form can also be obtained by calling the estate tax section at 360-570-3265, option 2.

**(c) Department may elect to serve as personal representative.**

(i) The department may elect to serve as the personal representative of an escheat estate under RCW 11.28.120. The department will review the submitted notice of escheat property and then elect or decline to serve as personal representative. A copy of this election is mailed to the person reporting the escheat property.

(ii) **Written notice to the department of proceedings.** If the department declines to serve as personal representative, the appointed personal representative must serve the department with written notice at least twenty days prior to any hearing on proceedings involving the valuation or sale of property, on any petition for the allowance of fees, and on all interim reports, final accounts or petitions for the determination of heirship. Failure to comply with the notice provisions of RCW 11.08.170 could result in any orders being voided.

**(d) Oversight of estate when department declines to serve as personal representative—Opposition to nonintervention powers—Review of pleadings and petitions.** The department supervises escheat property during probate. The department has the duty to protect and conserve escheat property for the benefit of the permanent common school fund until the property is forwarded to the state treasurer or the real property is deeded over to the department of natural resources. Because of the duty to protect and conserve escheat property, the department will oppose the granting of nonintervention powers to the personal representative. The department will review all pleadings and petitions to determine the progression of probate and to determine if fees and expenses charged to the estate are appropriate.

**(e) Heirs of escheat estates.** Heirs to an estate may be located after the estate escheats to the state. The personal representative of an escheat estate or a claimed heir must provide the department with all information and documentary evidence available that supports the heir's claim. All supporting documents must be in the English language when submitted to the department. The English translation of any foreign document shall be authenticated as reasonably required by the department.

(i) Under RCW 11.08.240 all claims for escheated property must be made within seven years from the date of issu-

ance of letters testamentary or of administration. The claim is made to the court having original jurisdiction of the estate and a copy served upon the department.

(ii) In all cases where there is a court hearing or the taking of a deposition on the question of a claimed heir, the personal representative shall give the department twenty days written notice of such hearing or matter.

(iii) The personal representative must give the department at least twenty days written notice of the hearing on the final account and petition for distribution.

(iv) The department has no statutory authority to pay interest on escheat refunds.

**(3) Absentee distributee (missing heir).**

(a) Absentee distributee means any person who is a beneficiary of a will or trust who has not been located. If a personal representative cannot locate a beneficiary of a will or trust the personal representative is required to follow the procedures outlined in RCW 11.76.200 through 11.76.230.

**(b) Appointment of agent—Bond.**

(i) When an estate has been or is about to be distributed by decree of the court to any person who has not been located, the personal representative must petition the court to appoint an agent for the purposes of representing the interests of the absentee distributee and to take possession and charge of the property for the benefit of the absentee person.

(ii) The agent shall make, subscribe, and file an oath for the faithful performance of his or her duties, and shall give a bond to the state, to be approved by the court before the agent receives the property.

(iii) The agent shall hold the property for three years. If the absentee distributee is not found or does not come forward to make a claim, the property must be turned over to the county treasurer. Any property not in the form of cash shall be sold under order of the court and all funds after deducting a reasonable sum for expenses and services of the agent. The expenses and the fees of the agent are fixed by the court.

**(c) County treasurer.** The county treasurer is required to issue a triplicate receipt for the funds, one to be filed with the county auditor, one with the probate court, and one with the department. If the funds remain in the county treasury unclaimed for a period of four years and ninety days, the treasurer is required to remit them to the department for deposit in the permanent common school fund.

**(d) Claims made after the time limitation.** After any time limitation prescribed in RCW 11.76.220, 11.76.240 or 11.76.243 the absentee claimant may notify the department of his or her claim and file in the court which had jurisdiction of the original probate a petition claiming the assets of the estate. Upon proof being made to the court and the determination that the claimant is entitled to the property the assets shall be paid to the claimant without interest.

**WSR 05-24-060**

**PROPOSED RULES**

**PUBLIC DISCLOSURE COMMISSION**

[Filed December 2, 2005, 11:31 a.m.]

Original Notice.

Preproposal statement of inquiry was filed as WSR 05-19-077.

Title of Rule and Other Identifying Information: WAC 390-37-136 relating to production of documents and use at hearing (adjudicative proceeding).

Hearing Location(s): Public Disclosure Commission, 711 Capitol Way, Room 206, Olympia, WA 98504, on January 24, 2006, at 9:30 a.m.

Date of Intended Adoption: January 24, 2006.

Submit Written Comments to: Doug Ellis, Assistant Director, 711 Capitol Way, Room 206, Olympia, WA 98504, e-mail dellis@pdc.wa.gov, fax (206) [(360)] 753-1112, by January 20, 2006.

Assistance for Persons with Disabilities: Contact Chip Beatty by phone (360) 586-0544.

Purpose of the Proposal and Its Anticipated Effects, Including Any Changes in Existing Rules: To incorporate modifications for the submission of hearing materials to include timing, electronic format, spacing, page limits, etc.

Reasons Supporting Proposal: To update outdated rule in light of current technology and clarify the process for submission of hearing materials.

Statutory Authority for Adoption: RCW 42.17.370.

Statute Being Implemented: RCW 42.17.370.

Rule is not necessitated by federal law, federal or state court decision.

Agency Comments or Recommendations, if any, as to Statutory Language, Implementation, Enforcement, and Fiscal Matters: The rule amendment is designed to update procedures for the production and use of documents at hearings of the Public Disclosure Commission (PDC).

Name of Proponent: Public Disclosure Commission, governmental.

Name of Agency Personnel Responsible for Drafting and Implementation: Doug Ellis, 711 Capitol Way, Room 206, Olympia, WA 98504, (360) 664-2735; and Enforcement: Phil Stutzman, 711 Capitol Way, Room 206, Olympia, WA 98504, (360) 664-8853.

No small business economic impact statement has been prepared under chapter 19.85 RCW. The implementation of this rule amendment has minimal impact on small businesses.

A cost-benefit analysis is not required under RCW 34.05.328. The PDC is not an agency listed in subsection (5)(a)(i) of section 201. Further, the PDC does not voluntarily make section 201 applicable to this rule adoption pursuant to subsection (5)(a)(i) of section 201, and, to date, the Joint Administrative Rules Review Committee has not made section 201 application [applicable] to this rule adoption.

December 2, 2005

Vicki Rippie

Executive Director

**AMENDATORY SECTION** (Amending WSR 03-22-065, filed 11/4/03, effective 12/5/03)

**WAC 390-37-136 Production of documents and use at hearing and other hearing procedures (adjudicative proceedings).** (1) ~~((Upon request by either the agency or its legal representative, or the party against whom the enforcement action is being taken or his/her representative, copies of~~

~~all materials to be presented at the adjudicative proceeding shall be provided to the requester within seven calendar days of the request but, for good cause shown, not less than three business days prior to the date of the hearing.~~

~~(2) When exhibits of a documentary character are to be offered into evidence at the adjudicative proceeding, the party offering the exhibit shall provide a minimum of ten copies.~~

~~(3) If documentary evidence has not been exchanged prior to the hearing under subsection (1) of this section, the parties shall arrive at the hearing location in sufficient time before the time scheduled for the adjudicative proceeding for the purpose of exchanging copies of exhibits to be introduced.) Unless a prehearing order states otherwise, the provisions of this rule apply to evidence and written argument (legal briefs) filed and served in hearings (adjudicative proceedings). Parties or the executive director may request a prehearing conference if provisions of this rule need to be adjusted or if the provisions are not adhered to by the parties.~~

~~(2) The parties are encouraged to exchange copies of proposed exhibits, exhibit lists and witness lists, at least eight calendar days prior to the date of the hearing. The parties are encouraged to exchange documents by e-mail. The parties are encouraged to confer and determine whether there are any objections to the evidence and whether any agreements or stipulations can be reached regarding proposed exhibits, witnesses, and legal and factual issues.~~

~~(3)(a) Unless the commission determines otherwise, when evidence is to be offered at the adjudicative proceeding or when briefs are to be submitted at the adjudicative proceeding, the party offering the evidence or brief shall file a copy of proposed exhibits, exhibit lists, witness lists, and briefs with the commission via an e-mail to the executive director or his or her designee by the date and time designated by the executive director or designee, which is typically by 1:00 p.m. Pacific Time at least eight calendar days prior to the hearing. The e-mail shall provide the name of the party submitting the documents, the total number of pages, the software used to prepare the document, and the name, address, telephone number and e-mail address of the person sending the e-mail message.~~

~~(b) In the event electronic submission is not readily available to a *pro se* respondent or the evidence is not suited to e-mail transmission, other means of providing these materials to the commission may be approved by the chair or the executive director, or their designees if requested in advance of the date and time in (a) of this subsection.~~

~~(c) On the day the parties provide these materials electronically to the commission, they shall also mail or otherwise deliver a paper (or hard copy) set of the materials to the commission.~~

~~(d) The parties shall confirm in advance with the executive director that any documents provided electronically are able to be accessed by software available at the agency. If they are not accessible, the executive director shall direct how the documents are to be submitted.~~

~~(e) The documents are considered filed when received during actual business hours at the commission office. If received after actual business hours, they will be deemed filed the next business day.~~

(4) Respondent's exhibits shall be numbered R-1, R-2, etc. Commission staff exhibits shall be numbered S-1, S-2, etc. Jointly submitted exhibits shall be numbered J-1, J-2, etc. If an exhibit is not jointly submitted but there is no objection to it by the responding party, the party offering the exhibit shall designate agreed-to exhibits on the party's exhibit list.

(5) Briefs shall contain the name of the respondent in the caption and the cause number. Briefs shall be no more than twenty-five pages, double-spaced, excluding attachments or exhibits.

(6) The parties shall inform the executive director of any special equipment necessary for the adjudicative proceeding at the time documents are filed with the commission.

**WSR 05-24-081**  
**PROPOSED RULES**  
**DEPARTMENT OF**  
**FISH AND WILDLIFE**

[Filed December 5, 2005, 3:10 p.m.]

Original Notice.

Preproposal statement of inquiry was filed as WSR 05-10-104.

Title of Rule and Other Identifying Information: WAC 232-12-421 Hunt or possess big game without an access permit, 232-12-422 Hunt or possess a wild animal or wild bird without an access permit, and 232-12-423 Public hunting and access agreements defined.

Hearing Location(s): Natural Resources Building, Commission Office, 1111 Washington Street S.E., Olympia, WA 98501-1091, (360) 902-2267, on January 19, 2006, at 8:00 a.m.

Date of Intended Adoption: January 19, 2006.

Submit Written Comments to: Attn: Wildlife Program Commission Meeting Public Comments, 600 Capitol Way North, Olympia, WA 98501-1091, e-mail Wildthing@dfw.wa.gov, fax (360) 902-2612, by Monday, January 9, 2006.

Assistance for Persons with Disabilities: Contact Susan Yeager by January 17, 2006, TTY (360) 902-2207 or (360) 902-2267.

Purpose of the Proposal and Its Anticipated Effects, Including Any Changes in Existing Rules: WAC 232-12-421, this proposal establishes a new rule, which makes hunting or possessing big game taken on private lands under agreement with the department without an access permit punishable as a gross misdemeanor or class C felony as appropriate.

WAC 232-12-422, this proposal establishes a new rule, which makes hunting or possessing a wild animal or wild bird taken on private lands under agreement with the department without an access permit punishable as a misdemeanor.

WAC 232-12-423, this proposal establishes a new rule that defines "public hunting" for the purpose of paying damage claims and defines department access programs.

Reasons Supporting Proposal: WAC 232-12-421, this rule raises the level of penalty for trespass for the purpose of

big game hunting on those private lands under agreement with the department.

WAC 232-12-422, this rule provides greater clarity of violation of access permit requirements than simple trespass or failure to obey posted signs.

WAC 232-12-423, this rule clarifies what constitutes public hunting for the purpose of claiming damage and allows the department to craft hunting opportunities that will help alleviate or reduce crop damage.

Statutory Authority for Adoption: RCW 77.12.047.

Statute Being Implemented: RCW 77.12.047.

Rule is not necessitated by federal law, federal or state court decision.

Name of Proponent: Washington Fish and Wildlife Commission, governmental.

Name of Agency Personnel Responsible for Drafting and Implementation: Dave Brittell, Natural Resources Building, Olympia, (360) 902-2504; and Enforcement: Bruce Bjork, Natural Resources Building, Olympia, (360) 902-2932.

No small business economic impact statement has been prepared under chapter 19.85 RCW. These rules regulate recreational hunters and do not directly regulate small business.

A cost-benefit analysis is not required under RCW 34.05.328. Not hydraulics rules.

December 5, 2005

Evan Jacoby

Rules Coordinator

NEW SECTION

**WAC 232-12-421 Hunt or possess big game without an access permit.** (1) It is unlawful to hunt for big game or possess big game taken on property in an access contract between the landowner or land manager and the department, unless:

(a) The hunter possesses a valid access permit provided on a standard form by the department, and issued to the hunter by the landowner, land manager, or the department in addition to all other required hunting licenses and permits; or

(b) The property is in a contract between the department and the landowner that does not restrict persons from hunting and does not require an access permit.

(2) Each big game animal possessed in violation of this section shall be treated as a separate offense under RCW 77.15.030.

(3) Violation of this section is punishable under RCW 77.15.410, unlawful recreational hunting of big game in the second degree, unless the hunting for or possession of big game constitutes unlawful recreational hunting of big game in the first degree.

NEW SECTION

**WAC 232-12-422 Hunt or possess a wild animal or wild bird without an access permit.** (1) It is unlawful to hunt for a wild bird or wild animal, except big game, or possess any wild bird or wild animal, except big game, taken on

property in an access contract between the landowner or land manager and the department, unless:

(a) The hunter possesses a valid access permit provided on a standard form by the department, and issued to the hunter by the landowner, land manager, or the department in addition to all other required hunting licenses and permits; or

(b) The property is in a contract between the department and the landowner that does not restrict persons from hunting and does not require an access permit.

(2) Violation of this section is punishable under RCW 77.15.400 or 77.15.430.

#### NEW SECTION

**WAC 232-12-423 Public hunting defined and access contracts.** "Public hunting" generally means that land is open to hunting for all licensed hunters.

(1) For the purpose of defining the term "public hunting" for payment of crop damage in RCW 77.36.060, "public hunting" has been allowed by the landowner when:

(a) The landowner opens the property on which the damage is claimed under RCW 77.36.040, for general access to all licensed hunters; or

(b) The landowner had entered into and complied with an access contract with the department covering the land(s) on which the damage is claimed under RCW 77.36.040, for the hunting season prior to the occurrence of the damage.

(2) Access contracts shall require that:

(a) The land is open to general access to all licensed hunters; or

(b) The landowner allows the department to select the hunters who are authorized to access the land; or

(c) The landowner and the department share selection of the hunters authorized to hunt on the landowner's land consistent with applicable commission policy or rule.

### WSR 05-24-082

#### PROPOSED RULES

#### DEPARTMENT OF FISH AND WILDLIFE

[Filed December 5, 2005, 3:11 p.m.]

Original Notice.

Preproposal statement of inquiry was filed as WSR 05-21-119.

Title of Rule and Other Identifying Information: WAC 232-12-011 Wildlife classified as protected shall not be hunted or fished and 232-12-014 Wildlife classified as endangered species.

Hearing Location(s): Natural Resources Building, 1111 Washington Street S.E., Olympia, WA 98504, on January 13-14, 2006, at 8:00 a.m.

Date of Intended Adoption: January 13, 2006.

Submit Written Comments to: Attn: Wildlife Program Commission Meeting Public Comments, 600 Capitol Way North, Olympia, WA 98501-1091, e-mail Wildthing@dfw.wa.gov, fax (360) 902-2612, by Wednesday, December 28, 2005.

Assistance for Persons with Disabilities: Contact Susan Yeager by January 10, 2006, TTY (360) 902-2207 or (360) 902-2267.

Purpose of the Proposal and Its Anticipated Effects, Including Any Changes in Existing Rules: Two rules are proposed to be amended: WAC 232-12-014, which identifies endangered species that are at risk of extirpation in the state and are in need of recovery actions to restore populations to health levels; and WAC 232-12-011, which identifies species in need of protection in Washington.

The purpose of the proposal is to add the streaked horned lark and the Taylor's checkerspot butterfly to the state's list of endangered species; add the Mazama pocket gopher to the state's list of threatened species; and to remove the Aleutian Canada goose from the state's list of threatened species. Endangered and threatened species are in need of special management consideration to recover populations to healthy levels and to keep them from being extirpated from Washington. Land managing agencies and local, state, and federal governments may use these lists to consider the needs of species of special concern and land management decisions.

Reasons Supporting Proposal: **Taylor's checkerspot butterfly** (*Euphydryas editha taylori*) was historically found on grassland habitats at thirty-eight known locations in Washington. The direct loss of grassland habitats to human development, coupled with degradation of grasslands by the invasion of shrubs and succession to Douglas-fir forest, has eliminated most of its habitat. The subspecies is now restricted to a small scattering of ten populations in Washington. Most populations in Washington support no more than a few hundred individuals, and several of the populations are extremely small and may be on the verge of extinction. Among five or six populations that appear to have gone extinct over the last ten years is one population that was estimated at 7,000 in 1997; it declined precipitously and appeared to be extinct by 2001. The subspecies became a candidate for listing under the federal Endangered Species Act in 2001. Taylor's checkerspot sites in Washington are located in four distinct areas, and may comprise three or more metapopulations. Habitat loss has increased isolation of the remaining populations and many are unlikely to be recolonized when they become extinct. The small size of many populations puts them at higher risk of extinction due to fires, disturbance, insecticides, and weather extremes, as well as the potential for reduced survival and reproductive success due to inbreeding. Several of the largest remaining populations occur on public lands, but most of these lands have uses that can conflict with butterfly conservation, including military training and recreation. Private lands occupied by Taylor's checkerspot are subject to development, agriculture, and gravel extraction that can eliminate habitat. Grassland sites, except where actively maintained, are being degraded by the invasion of Scotch broom, Douglas-fir, and numerous nonnative forbs and sod-forming grasses. The remaining populations of Taylor's checkerspot are unlikely to survive without recovery actions. For these reasons, the Washington Department of Fish and Wildlife (WDFW) recommends that Taylor's checkerspot butterfly be listed as endangered in the state of Washington.

The **streaked horned lark** (*Eremophila alpestris strigata*) was historically found in Washington on the prairies of southern Puget Sound, primarily in Pierce and Thurston counties. Streaked horned larks have declined with the loss of prairie habitats to development and succession to forest. With the cessation of burning of the prairies by Native Americans, Douglas-fir has spread over much of the prairie and introduced grasses, weeds, and Scotch broom have degraded much of the remainder. Streaked horned larks may have also been restricted to portions of the prairie where the vegetation was short and sparse due to excessive dryness or repeated burns. There is little information on historical populations. Streaked horned larks were reported to be a "very abundant summer resident of the gravelly prairies near Fort Steilacoom" in the 1850s. Streaked horned lark breeding in Washington is now limited to thirteen known sites: Six sites in the south Puget Sound; four sites along the outer coast; and three sites on islands in the Lower Columbia River. The total breeding population is estimated to be about three hundred thirty birds in Washington. All remaining nesting sites in the south Puget Sound area are on airports or military bases where grassland is maintained. Columbia River sites are affected by management of the islands, including deposition of dredge spoil and vegetation manipulation to discourage nesting by Caspian terns. Coastal sites may be affected by the spread of European beachgrass and disturbance by recreational activities. For these reasons WDFW recommends that the streaked horned lark be listed as endangered in the state of Washington.

The **Mazama pocket gopher** (*Thomomys mazama*) is a regional endemic found only in western Washington, western Oregon and northern California. The subspecific taxonomy of *T. mazama* is in the process of being revised, but in Washington, *T. mazama* is likely represented by three surviving subspecies: *T. m. yelmensis* is found on locations scattered on the remnants of prairie in Pierce and Thurston counties; *T. m. couchi* is found on grassland at a few localities near Shelton in Mason County, including the airport; and *T. m. melanops* is found on a few alpine meadows in Olympic National Park in Clallam County. Two additional subspecies that occurred around Tacoma (*T. m. tacomensis*) and in Wahkiakum County (*T. m. louiei*) appear to be extinct. The Washington population of the Mazama pocket gopher became a candidate for federal listing under the Endangered Species Act in 2002. Mazama pocket gophers are known to persist at twenty-seven sites scattered across the southern Puget Sound grasslands and on alpine meadows in the Olympics. These encompass three geographically isolated subspecies and many small populations on marginal sites that are unlikely to persist. Most gopher populations are restricted to grassland on remnant and former prairie sites. About half of the known gopher populations are on private lands, where they are threatened by residential development; degradation of habitat by heavy grazing of pastures and the invasion of Scotch broom and other weedy nonnative plants; and high mortality due to trapping, poisoning, and predation by cats and dogs. Gravel mining affects gopher habitat on some private lands. Most occupied habitat on public lands is affected by nonconservation uses including military training and recreation. Development of airport-related facilities and businesses, and

management of airport grassland can affect gopher populations at airports. The small size and isolation of most remaining populations of Mazama pocket gopher put them at risk of local extinction, and without increased protection, all but *T. m. melanops* in Olympic National Park could go extinct. For these reasons, WDFW recommends that the Mazama pocket gopher be listed as threatened by the state of Washington.

The **Aleutian Canada goose** (*Branta canadensis leucopareia*) was first added to the United States Department of Interior's list of endangered species in 1967. The primary cause of the population decline was attributed to predation by introduced arctic and red foxes. Control programs started in the 1950s have been successful in significantly reducing and eliminating foxes from several key islands. Aleutian Canada geese migrate from their breeding grounds in the Aleutian Islands in September, stopping along coastal areas of Washington (Willapa National Wildlife Refuge and surrounding fields and farms) en route to their wintering grounds in California and southwest Oregon. Hunting of Aleutian Canada geese is prohibited in Washington. In 1991, the species was downlisted by the United States Fish and Wildlife Service from endangered to threatened. The population was delisted in March 2001 when the population exceeded 28,000 birds. Aleutian geese have continued to increase, and currently number over 70,000. No significant circumstances exist in Washington to maintain the goose on the state's list of threatened species. For these reasons, WDFW recommends that the Aleutian Canada goose be removed from the list of threatened species in Washington.

Statutory Authority for Adoption: RCW 77.12.020.

Statute Being Implemented: RCW 77.12.020.

Rule is not necessitated by federal law, federal or state court decision.

Name of Proponent: Washington Fish and Wildlife Commission, governmental.

Name of Agency Personnel Responsible for Drafting and Implementation: Dave Brittell, Natural Resources Building, Olympia, (360) 902-2504; and Enforcement: Bruce Bjork, Natural Resources Building, Olympia, (360) 902-2932.

No small business economic impact statement has been prepared under chapter 19.85 RCW. These rules regulate recreational hunters and do not directly regulate small business.

A cost-benefit analysis is not required under RCW 34.05.328. Not hydraulics rules.

December 5, 2005

Evan Jacoby

Rules Coordinator

**AMENDATORY SECTION** (Amending Order 04-98, filed 5/12/04, effective 6/12/04)

**WAC 232-12-014 Wildlife classified as endangered species.** Endangered species include:

Common Name	Scientific Name
pygmy rabbit	<i>Brachylagus idahoensis</i>
fisher	<i>Martes pennanti</i>
gray wolf	<i>Canis lupus</i>



Common Name	Scientific Name
grizzly bear	<i>Ursus arctos</i>
sea otter	<i>Enhydra lutris</i>
killer whale	<i>Orcinus orca</i>
sei whale	<i>Balaenoptera borealis</i>
fin whale	<i>Balaenoptera physalus</i>
blue whale	<i>Balaenoptera musculus</i>
humpback whale	<i>Megaptera novaeangliae</i>
black right whale	<i>Balaena glacialis</i>
sperm whale	<i>Physeter macrocephalus</i>
Columbian white-tailed deer	<i>Odocoileus virginianus leucurus</i>
woodland caribou	<i>Rangifer tarandus caribou</i>
American white pelican	<i>Pelecanus erythrorhynchos</i>
brown pelican	<i>Pelecanus occidentalis</i>
sandhill crane	<i>Grus canadensis</i>
snowy plover	<i>charadrius alexandrinus</i>
upland sandpiper	<i>Bartramia longicauda</i>
spotted owl	<i>Strix occidentalis</i>
western pond turtle	<i>Clemmys marmorata</i>
leatherback sea turtle	<i>Dermochelys coriacea</i>
mardon skipper	<i>Polites mardon</i>
Oregon silverspot butterfly	<i>Speyeria zerene hippolyta</i>
Oregon spotted frog	<i>Rana pretiosa</i>
northern leopard frog	<i>Rana pipiens</i>
<u>Taylor's checkerspot</u>	<u><i>Euphydryas editha taylori</i></u>
<u>Streaked horned lark</u>	<u><i>Eremophila alpestris strigata</i></u>

**AMENDATORY SECTION** (Amending Order 02-98, filed 5/10/02, effective 6/10/02)

**WAC 232-12-011 Wildlife classified as protected shall not be hunted or fished.** Protected wildlife are designated into three subcategories: Threatened, sensitive, and other.

(1) Threatened species are any wildlife species native to the state of Washington that are likely to become endangered within the foreseeable future throughout a significant portion of their range within the state without cooperative management or removal of threats. Protected wildlife designated as threatened include:

Common Name	Scientific Name
western gray squirrel	<i>Sciurus griseus</i>
Steller (northern) sea lion	<i>Eumetopias jubatus</i>
North American lynx	<i>Lynx canadensis</i>
<del>((Aleutian Canada goose))</del>	<del>((<i>Branta Canadensis leucopareia</i>))</del>
bald eagle	<i>Haliaeetus leucocephalus</i>

Common Name	Scientific Name
ferruginous hawk	<i>Buteo regalis</i>
marbled murrelet	<i>Brachyramphus marmoratus</i>
green sea turtle	<i>Chelonia mydas</i>
loggerhead sea turtle	<i>Caretta caretta</i>
sage grouse	<i>Centrocercus urophasianus</i>
sharp-tailed grouse	<i>Phasianus columbianus</i>
<u>Mazama pocket gopher</u>	<u><i>Thomomys mazama</i></u>

(2) Sensitive species are any wildlife species native to the state of Washington that are vulnerable or declining and are likely to become endangered or threatened in a significant portion of their range within the state without cooperative management or removal of threats. Protected wildlife designated as sensitive include:

Common Name	Scientific Name
Gray whale	<i>Eschrichtius gibbosus</i>
Common Loon	<i>Gavia immer</i>
Peregrine Falcon	<i>Falco peregrinus</i>
Larch Mountain salamander	<i>Plethodon larselli</i>
Pygmy whitefish	<i>Prosopium coulteri</i>
Margined sculpin	<i>Cottus marginatus</i>
Olympic mudminnow	<i>Novumbra hubbsi</i>

(3) Other protected wildlife include:

Common Name	Scientific Name
cony or pika	<i>Ochotona princeps</i>
least chipmunk	<i>Tamias minimus</i>
yellow-pine chipmunk	<i>Tamias amoenus</i>
Townsend's chipmunk	<i>Tamias townsendii</i>
red-tailed chipmunk	<i>Tamias ruficaudus</i>
hoary marmot	<i>Marmota caligata</i>
Olympic marmot	<i>Marmota olympus</i>
Cascade golden-mantled ground squirrel	<i>Spermophilus saturatus</i>
golden-mantled ground squirrel	<i>Spermophilus lateralis</i>
Washington ground squirrel	<i>Spermophilus washingtoni</i>
red squirrel	<i>Tamiasciurus hudsonicus</i>
Douglas squirrel	<i>Tamiasciurus douglasii</i>
northern flying squirrel	<i>Glaucomys sabrinus</i>
wolverine	<i>Gulo gulo</i>
painted turtle	<i>Chrysemys picta</i>
California mountain kingsnake	<i>Lampropeltis zonata;</i>

All birds not classified as game birds, predatory birds or endangered species, or designated as threatened species or sensitive species; all bats, except when found in or immedi-

ately adjacent to a dwelling or other occupied building; mammals of the order *Cetacea*, including whales, porpoises, and mammals of the order *Pinnipedia* not otherwise classified as endangered species, or designated as threatened species or sensitive species. This section shall not apply to hair seals and sea lions which are threatening to damage or are damaging commercial fishing gear being utilized in a lawful manner or when said mammals are damaging or threatening to damage commercial fish being lawfully taken with commercial gear.

**WSR 05-24-085**  
**PROPOSED RULES**  
**DEPARTMENT OF**  
**LABOR AND INDUSTRIES**

[Filed December 6, 2005, 9:37 a.m.]

Original Notice.

Preproposal statement of inquiry was filed as WSR 05-13-146.

Title of Rule and Other Identifying Information: Chapter 296-46B WAC, Electrical safety standards, administration, and installation.

Hearing Location(s): Hal Holmes Community Center, 209 North Ruby Street, Ellensburg, WA, on January 11, 2006, at 11:00 a.m.; and at the Department of Labor and Industries, 7273 Linderson Way S.W., Tumwater, WA, on January 12, 2006, at 9:00 a.m.

Date of Intended Adoption: February 7, 2006.

Submit Written Comments to: Sally Elliott, Specialty Compliance Services Division, P.O. Box 44400, Olympia, WA 98504-4400, e-mail [yous235@lni.wa.gov](mailto:yous235@lni.wa.gov), fax (360) 902-5292, by January 12, 2006.

Assistance for Persons with Disabilities: Contact Sally Elliott by January 1, 2006, at [yous235@lni.wa.gov](mailto:yous235@lni.wa.gov) or (360) 902-6411.

Purpose of the Proposal and Its Anticipated Effects, Including Any Changes in Existing Rules: The purpose of this rule making is to review the electrical rules for additions or revisions. The electrical rules are reviewed on an annual basis to ensure the rules are consistent with the national consensus standards, industry practice, and to clarify the rules.

The rule making will:

- Update references to the National Electrical Code (NEC) and National Fire Protection Association (NFPA) throughout the rule.
- Update the wording to be consistent with the ANSI and NEC, which will clarify the wording for ease of use and understanding.
- Make minor technical changes that will align the rules with industry installation practices.
- Make necessary housekeeping changes.
- Make substantive and clarifying changes based on recommendations from stakeholder groups and the Electrical Board.

Reasons Supporting Proposal: See Purpose above.

Statutory Authority for Adoption: RCW 19.28.006, 19.28.010, 19.28.031, 19.28.041, 19.28.061, 19.28.101,

19.28.131, 19.28.161, 19.28.171, 19.28.191, 19.28.201, 19.28.211, 19.28.241, 19.28.251, 19.28.281, 19.28.311, 19.28.321, 19.28.400, 19.28.420, 19.28.490, 19.28.551.

Statute Being Implemented: Chapter 19.28 RCW.

Rule is not necessitated by federal law, federal or state court decision.

Name of Proponent: Department of Labor and Industries, governmental.

Name of Agency Personnel Responsible for Drafting: Ron Fuller, Tumwater, Washington, (360) 902-5249; Implementation and Enforcement: Patrick Woods, Tumwater, Washington, (360) 902-6348.

No small business economic impact statement has been prepared under chapter 19.85 RCW. The department determined the proposed rules do not require a small business economic impact statement because the costs associated with the proposed changes are exempted by law since the proposed changes are updating the rule based upon national consensus codes and clarifying the rule for ease of use and understanding (see RCW 34.05.310 (4)(c) and (d)).

A cost-benefit analysis is not required under RCW 34.05.328. The department determined the proposed changes do not require a cost-benefit analysis because the costs associated with the proposed changes are exempted by law since the proposed changes are updating the rule based upon national consensus codes and clarifying the rule for ease of use and understanding (see RCW 34.05.328 (5)(b)(iii) and (iv)).

December 6, 2005

Gary Weeks

Director

**AMENDATORY SECTION** (Amending WSR 05-10-024, filed 4/26/05, effective 6/30/05)

**WAC 296-46B-010 General. Adopted standards - inspectors - city inspection - variance.**

(1) The 2005 edition of the National Electrical Code (NFPA 70 - 2005) including Annex A, B, and C; the 2003 edition of standard for the Installation of Stationary Pumps for Fire Protection (NFPA 20 - 2003); the 2002 edition of standard for Emergency and Standby Power Systems (NFPA 110 - 2002); Commercial Building Telecommunications Cabling Standard (ANSI/TIA/EIA 568-B.1-May 2001 including Annex 1 through 5); Commercial Building Standard for Telecommunications Pathway and Spaces (ANSI/TIA/EIA 569-A-7 December 2001 including Annex 1 through 4); Commercial Building Grounding and Bonding Requirements for Telecommunications (ANSI/TIA/EIA 607 - A - 2002); Residential Telecommunications Cable Standard (ANSI/TIA/EIA 570-A-December 2001); American Railroad Engineering and Maintenance of Way Association - 2005 Communications and Signal Manual; and the National Electrical Safety Code (NESC C2-2002 excluding Appendixes A and B) are hereby adopted by reference as part of this chapter. Other codes, manuals, and reference works referred to in this chapter are available for inspection and review in the Olympia office of the electrical section of the department during business hours.

The requirements of this chapter will be observed where there is any conflict between this chapter and the National Electrical Code (NFPA 70), Centrifugal Fire Pumps (NFPA 20), the Emergency and Standby Power Systems (NFPA 110), ANSI/TIA/EIA 568-B, ANSI/TIA/EIA 569-A, ANSI/TIA/EIA 607, ANSI/TIA/EIA 570, or the NESC C2-2002.

The National Electrical Code will be followed where there is any conflict between standard for Installation of Stationary Pumps for Fire Protection (NFPA 20), standard for Emergency and Standby Power Systems (NFPA 110), ANSI/TIA/EIA 568-B, ANSI/TIA/EIA 569-A, ANSI/TIA/EIA 607, ANSI/TIA/EIA 570, or the NESC C2-2002 and the National Electrical Code (NFPA 70).

(2) Electrical inspectors will give information as to the interpretation or application of the standards in this chapter, but will not lay out work or act as consultants for contractors, owners, or users.

(3) The department may enforce city electrical ordinances where those governmental agencies do not make electrical inspections under an established program.

(4) A variance from the electrical installation requirements of chapter 19.28 RCW or this chapter may be granted by the department when it is assured that equivalent objectives can be achieved by establishing and maintaining effective safety.

(a) Any electrical permit holder may request a variance.

(b) The permit holder must make the request in writing, using a form provided by the department, to the chief electrical inspector. The request must include:

(i) A description of the installation as installed or proposed;

(ii) A detailed list of the applicable code violations;

(iii) A detailed list of safety violations;

(iv) A description of the proposal for meeting equivalent objectives for code and/or safety violations; and

(v) Appropriate variance application fee as listed in WAC 296-46B-905.

**Inspection.**

(5) Electrical wiring or equipment subject to this chapter must be sufficiently accessible, at the time of inspection, to allow the inspector to visually inspect the installation to verify conformance with the NEC and any other electrical requirements of this chapter.

(6) Cables or raceways, fished according to the NEC, do not require visual inspection.

(7) All required equipment grounding conductors installed in concealed cable or flexible conduit systems must be completely installed and made up at the time of the rough-in cover inspection.

(8) The installation of all structural elements and mechanical systems (e.g., framing, plumbing, ducting, etc.) must be complete in the area(s) where electrical inspection is requested. Prior to completion of an exterior wall cover inspection, either:

(a) The exterior shear panel/sheathing nail inspection must be completed by the building code inspector; or

(b) All wiring and device boxes must be a minimum of 63 mm (2 1/2") from the exterior surface of the framing member; or

(c) All wiring and device boxes must be protected by a steel plate a minimum of 1.6 mm (1/16") thick and of appropriate width and height installed to cover the area of the wiring or box.

(9) In order to meet the minimum electrical safety standards for installations, all materials, devices, appliances, and equipment, not exempted in chapter 19.28 RCW, must conform to applicable standards recognized by the department, be listed, or field evaluated. Other than as allowed in WAC 296-46B-030(3), equipment must not be energized until such standards are met unless specific permission has been granted by the chief electrical inspector.

(10) The department will recognize the state department of transportation as the inspection authority for telecommunications systems installation within the rights of way of state highways provided the department of transportation maintains and enforces an equal, higher or better standard of construction and of materials, devices, appliances and equipment than is required for telecommunications systems installations by chapter 19.28 RCW and this chapter.

**Inspection - move on buildings and structures.**

(11) All buildings or structures relocated into or within the state:

(a) Other than residential, wired inside the United States (U.S.) must be inspected to ensure compliance with current requirements of chapter 19.28 RCW and the rules developed by the department.

(b) Wired outside the U.S. or Canada must be inspected to ensure compliance with all current requirements of chapter 19.28 RCW and the rules developed by the department.

(12) Residential buildings or structures wired in the U.S., to NEC requirements, and moved into or within a county, city, or town must be inspected to ensure compliance with the NEC requirements in effect at the time and place the original wiring was made. The building or structure must be inspected to ensure compliance with all current requirements of chapter 19.28 RCW and the rules developed by the department if:

(a) The original occupancy classification of the building or structure is changed as a result of the move; or

(b) The building or structure has been substantially remodeled or rehabilitated as a result of the move.

(13) Residential buildings or structures wired in Canada to Canadian Electrical Code (CEC) standards and moved into or within a county, city, or town, must be inspected to ensure compliance with the following minimum safety requirements:

(a) Service, service grounding, and service bonding must comply with the current chapter 19.28 RCW and rules adopted by the department.

(b) Canadian Standards Association (CSA) listed Type NMD cable is allowed with the following qualifications:

(i) CSA listed Type NMD cable, American Wire Gauge #10 and smaller installed after 1964 utilizing an equipment grounding conductor smaller than the phase conductors, must be:

(A) Replaced with a cable utilizing a full-size equipment grounding conductor; or

(B) Protected by a ground fault circuit interrupter protection device.

(ii) CSA listed Type NMD cable, #8 AWG and larger, must:

(A) Utilize an equipment grounding conductor sized according to the requirements of the NEC in effect at the time of the installation;

(B) Be protected by a ground fault circuit interrupter protection device; or

(C) Be replaced.

(c) Other types of wiring and cable must be:

(i) Replaced with wiring listed or field evaluated in accordance with U.S. standards by a laboratory approved by the department; or

(ii) Protected by a ground fault circuit interrupter protection device and arc fault circuit protection device.

(d) Equipment, other than wiring or panelboards, manufactured and installed prior to 1997 must be listed and identified by laboratory labels approved by the department or CSA labels.

(e) All panelboards must be listed and identified by testing laboratory labels approved by the department with the following qualifications:

(i) CSA listed panelboards labeled "Suitable for Use as Service Equipment" will be considered to be approved as "Suitable for Use only as Service Equipment."

(ii) CSA listed panelboards must be limited to a maximum of 42 circuits.

(iii) CSA listed panelboards used as lighting and appliance panelboards as described in the NEC, must meet all current requirements of the NEC and this chapter.

(f) Any wiring or panelboards replaced or changed as a result of the move must meet current requirements of chapter 19.28 RCW and this chapter.

(g) The location, type, and ground fault circuit interrupter protection of receptacles and equipment in a bathroom, kitchen, basement, garage, or outdoor area must meet the Washington requirements in effect at the time the wiring was installed.

(h) 4, 15-ampere, kitchen small appliance circuits will be accepted in lieu of 2, 20-ampere, kitchen small appliance circuits. Receptacles will not be required to be added on kitchen peninsular or island counters.

(i) Spacing requirements for all other receptacles must meet the Washington requirements in effect at the time the wiring was installed.

(j) Receptacles installed above baseboard or fixed wall space heaters must be removed and the outlet box covered with a blank cover. The receptacle is required to be relocated as closely as possible to the existing location.

(k) Lighting outlet and switch locations must meet the Washington requirements in effect at the time the wiring was installed.

(l) Dedicated 20-ampere small appliance circuits are not required in dining rooms.

(m) Electric water heater branch circuits must be adequate for the load.

(n) The location, type, and circuit protection of feeders must meet the Washington requirements in effect at the time the wiring was installed.

**Classification or definition of occupancies.**

(14) Occupancies are classified and defined as follows:

(a) Educational facility refers to a building or portion of a building used primarily for educational purposes by six or more persons at one time for twelve hours per week or four hours in any one day. Educational occupancy includes: Schools (preschool through grade twelve), colleges, academies, universities, and trade schools.

(b) Institutional facility refers to a building or portion of a building used primarily for detention and correctional occupancies where some degree of restraint or security is required for a time period of twenty-four or more hours. Such occupancies include, but are not restricted to: Penal institutions, reformatories, jails, detention centers, correctional centers, and residential-restrained care.

(c) Health or personal care facility. Health or personal care facility refers to buildings or parts of buildings that contain, but are not limited to, facilities that are required to be licensed by the department of social and health services or the department of health (e.g., hospitals, nursing homes, private alcoholism hospitals, private psychiatric hospitals, boarding homes, alcoholism treatment facilities, maternity homes, birth centers or childbirth centers, residential treatment facilities for psychiatrically impaired children and youths, and renal hemodialysis clinics) and medical, dental or chiropractic offices or clinics, outpatient or ambulatory surgical clinics, and such other health care occupancies where patients who may be unable to provide for their own needs and safety without the assistance of another person are treated.

(i) "Hospital" means any institution, place, building, or agency providing accommodations, facilities and services over a continuous period of twenty-four hours or more, for observation, diagnosis, or care of two or more individuals not related to the operator who are suffering from illness, injury, deformity, or abnormality, or from any other condition for which obstetrical, medical, or surgical services would be appropriate for care or diagnosis.

(ii) "Nursing home," "nursing home unit" or "long-term care unit" means a group of beds for the accommodation of patients who, because of chronic illness or physical infirmities, require skilled nursing care and related medical services but are not acutely ill and not in need of the highly technical or specialized services ordinarily a part of hospital care.

(iii) "Boarding home" means any home or other institution, however named, which is advertised, announced, or maintained for the express or implied purpose of providing board and domiciliary care to seven or more aged persons not related by blood or marriage to the operator. It must not include any home, institution, or section thereof which is otherwise licensed and regulated under the provisions of state law providing specifically for the licensing and regulation of such home, institution, or section thereof.

(iv) "Private alcoholism hospital" means an institution, facility, building, or equivalent designed, organized, maintained, and operated to provide diagnosis, treatment, and care of individuals demonstrating signs or symptoms of alcoholism, including the complications of associated substance use and other medical diseases that can be appropriately treated and cared for in the facility and providing accommodations, medical services, and other necessary services over a continuous period of twenty-four hours or more for two or more individuals unrelated to the operator, provided that this chap-

ter will not apply to any facility, agency, or other entity which is owned and operated by a public or governmental body.

(v) "Alcoholism treatment facility" means a private place or establishment, other than a licensed hospital, operated primarily for the treatment of alcoholism.

(vi) "Private psychiatric hospital" means a privately owned and operated establishment or institution which: Provides accommodations and services over a continuous period of twenty-four hours or more, and is expressly and exclusively for observing, diagnosing, or caring for two or more individuals with signs or symptoms of mental illness, who are not related to the licensee.

(vii) "Maternity home" means any home, place, hospital, or institution in which facilities are maintained for the care of four or more women, not related by blood or marriage to the operator, during pregnancy or during or within ten days after delivery: Provided, however, that this definition will not apply to any hospital approved by the American College of Surgeons, American Osteopathic Association or its successor.

(viii) "Birth center" or "childbirth center" means a type of maternity home which is a house, building, or equivalent organized to provide facilities and staff to support a birth service, provided that the birth service is limited to low-risk maternal clients during the intrapartum period.

(ix) "Ambulatory surgical facility" means a facility, not a part of a hospital, providing surgical treatment to patients not requiring inpatient care in a hospital. This term does not include a facility in the offices of private physicians or dentists, whether for individual or group practice, if the privilege of using such facility is not extended to physicians or dentists outside the individual or group practice. (NEC; Ambulatory Health Care Center.)

(x) "Hospice care center" means any building, facility, place, or equivalent, organized, maintained, and operated specifically to provide beds, accommodations, facilities, and services over a continuous period of twenty-four hours or more for palliative care of two or more individuals, not related to the operator, who are diagnosed as being in the latter stages of an advanced disease which is expected to lead to death.

(xi) "Renal hemodialysis clinic" means a facility in a building or part of a building which is approved to furnish the full spectrum of diagnostic, therapeutic, and rehabilitative services required for the care of renal dialysis patients (including inpatient dialysis furnished directly or under arrangement). (NEC; Ambulatory Health Care Center.)

(xii) "Medical, dental, and chiropractic clinic" means any clinic or physicians' office where patients are not regularly kept as bed patients for twenty-four hours or more. Electrical plan review not required.

(xiii) "Residential treatment facility for psychiatrically impaired children and youth" means a residence, place, or facility designed and organized to provide twenty-four-hour residential care and long-term individualized, active treatment for clients who have been diagnosed or evaluated as psychiatrically impaired.

(xiv) "Adult residential rehabilitation center" means a residence, place, or facility designed and organized primarily to provide twenty-four-hour residential care, crisis and short-

term care and/or long-term individualized active treatment and rehabilitation for clients diagnosed or evaluated as psychiatrically impaired or chronically mentally ill as defined herein or in chapter 71.24 RCW.

(xv) "Group care facility" means a facility other than a foster-family home maintained and operated for the care of a group of children on a twenty-four-hour basis.

(d) Licensed day care centers.

(i) "Child day care center" means a facility providing regularly scheduled care for a group of children one month of age through twelve years of age for periods less than twenty-four hours; except, a program meeting the definition of a family child care home will not be licensed as a day care center without meeting the requirements of WAC 388-150-020(5).

(ii) "School-age child care center" means a program operating in a facility other than a private residence accountable for school-age children when school is not in session. The facility must meet department of licensing requirements and provide adult supervised care and a variety of developmentally appropriate activities.

(iii) "Family child day care home" means the same as "family child care home" and "a child day care facility" licensed by the state, located in the family abode of the person or persons under whose direct care and supervision the child is placed, for the care of twelve or fewer children, including children who reside at the home. Electrical plan review not required.

**Plan review for educational, institutional or health care facilities and other buildings.**

(15) Plan review is a part of the electrical inspection process; its primary purpose is to determine:

(a) That service/feeder conductors are calculated and sized according to the proper NEC or WAC article or section;

(b) The classification of hazardous locations; and

(c) The proper design of emergency and standby systems.

(16) Electrical plan review.

(a) Electrical plan review is not required for:

(i) Lighting specific projects that result in an electrical load reduction on each feeder involved in the project;

(ii) Low voltage systems;

(iii) ~~(Projects where the:~~

~~Service and feeder load calculation is affected by five percent or less;~~

~~Work does not involve critical branch circuits or feeders as defined in NEC 517.2; and~~

~~Affected service or feeder does not exceed 250 volts, 400 amperes;))~~ Modifications to existing electrical installations where all of the following conditions are met:

• Service or distribution equipment involved is rated not more than 400 amperes and does not exceed 250 volts;

• Does not involve emergency systems other than listed unit equipment per NEC 700.12(E);

• Does not involve branch circuits or feeders of an essential electrical system as defined in NEC 517.2; and

• Service and feeder load calculations are increased by 5% or less.

(iv) Stand-alone utility fed services that do not exceed 250 volts, 400 amperes where the project's distribution system does not include:

- Emergency systems other than listed unit equipment per NEC 700.12(~~(E)~~)(F);
- Critical branch circuits or feeders as defined in NEC 517.2; or
- A required fire pump system.

(b) Electrical plan review is required for all other new or altered electrical projects in educational, institutional, or health care occupancies classified or defined in this chapter.

(c) If a review is required, the electrical plan must be submitted for review and approval before the electrical work is begun.

(d) Electrical plans.

(i) The plan must be submitted for plan review prior to beginning any electrical inspection. If a plan is rejected during the plan review process, no electrical inspection(s) may proceed until the plan is resubmitted and a conditional acceptance is granted.

(ii) The submitted plan will receive a preliminary review within seven business days after receipt by the department.

(iii) If the submitted plan:

Is rejected at the preliminary review, no inspection(s) will be made on the project.

Receives conditional acceptance, the permit holder may request a preliminary inspection(s) in writing to the department. The request must note that the preliminary inspection(s) is conditional and subject to any alterations required from the final plan review process.

(iv) Once the submitted plan has plan review approval, the approved plan must be available on the job site for use by the electrical inspector.

(v) The approved plan must be available on the job site, for use by the electrical inspector, prior to the final electrical inspection.

(vi) If the approved plan requires changes from the conditionally accepted plan, alterations to the project may be required to make the project comply with the approved plan.

(e) All electrical plans for educational facilities, hospitals and nursing homes must be prepared by, or under the direction of, a consulting engineer registered under chapter 18.43 RCW, and chapters 246-320, 180-29, and 388-97 WAC and stamped with the engineer's mark and signature.

(f) Refer plans for department review to the Electrical Section, Department of Labor and Industries, P.O. Box 44460, Olympia, Washington 98504-4460.

(g) Plans for projects within cities that perform electrical inspections within their jurisdiction, and provide an electrical plan review program that equals or exceeds the department's program in plans examiner minimum qualifications per chapter 19.28 RCW, must be submitted to that city for review, unless the agency regulating the installation specifically requires review by the department.

(h) Plans to be reviewed by the department must be legible, identify the name and classification of the facility, clearly indicate the scope and nature of the installation and the person or firm responsible for the electrical plans. The plans must clearly show the electrical installation or alteration in floor plan view, include switchboard and/or panel-

board schedules and when a service or feeder is to be installed or altered, must include a riser diagram, load calculation, fault current calculation and interrupting rating of equipment. Where existing electrical systems are to supply additional loads, the plans must include documentation that proves adequate capacity and ratings. The plans must be submitted with a plan review submittal form available from the department. Plan review fees are not required to be paid until the review is completed. Plans will not be returned until all fees are paid. Fees will be calculated based on the date the plans are received by the department.

(i) The department may perform the plan review for new or altered electrical installations of other types of construction when the owner or electrical contractor makes a voluntary request for review.

(j) For existing structures where additions or alterations to feeders and services are proposed, Article 220.35(1) NEC may be used. If Article 220.35(1) NEC is used, the following is required:

(i) The date of the measurements.

(ii) A statement attesting to the validity of the demand data, signed by a professional electrical engineer or the electrical administrator of the electrical contractor performing the work.

(iii) A diagram of the electrical system identifying the point(s) of measurement.

(iv) Building demand measured continuously on the highest-loaded phase of the feeder or service over a thirty-day period, with demand peak clearly identified. (Demand peak is defined as the maximum average demand over a fifteen-minute interval.)

#### **Wiring methods for designated building occupancies.**

(17) Wiring methods, equipment and devices for health or personal care, educational and institutional facilities as defined or classified in this chapter and for places of assembly for one hundred or more persons must comply with Tables 010-1 and 010-2 of this chapter and the notes thereto. The local building authority will determine the occupant load of places of assembly.

(18) Listed tamper-resistant receptacles or listed tamper-resistant receptacle cover plates are required in all licensed day care centers, all licensed children group care facilities and psychiatric patient care facilities where accessible to children five years of age and under. Listed tamper-resistant receptacles are required in psychiatric patient care facilities where accessible to psychiatric patients over five years of age.

#### **Notes to Tables 010-1 and 010-2.**

1. Wiring methods in accordance with the NEC unless otherwise noted.

2. Metallic or nonmetallic raceways, MI, MC, or AC cable, except that ~~((metallic raceway or cable is required in places of assembly))~~ in places of assembly located within educational or institutional facilities, wiring methods must conform to NEC 518.4(a). Places of assembly located within educational or institutional facilities may not be wired according to NEC 518.4(b) or (c).

3. Limited energy system may use wiring methods in accordance with the NEC.

Table 010-1 Health or Personal Care Facilities

Health or Personal Care Facility Type <sup>(1)</sup>	Plan Review Required
Hospital	YES
Nursing home unit or long-term care unit	YES
Boarding home or assisted living facility	YES
Private alcoholism hospital	YES
Alcoholism treatment facility	YES
Private psychiatric hospital	YES
Maternity home	YES
Birth center or childbirth center	NO
Ambulatory surgery facility	YES
Hospice care center	NO
Renal hemodialysis clinic	YES
Medical, dental, and chiropractic clinic	NO
Residential treatment facility for psychiatrically impaired children and youth	YES
Adult residential rehabilitation center	YES
Group care facility	NO

Table 010-2 Educational and Institutional Facilities, Places of Assembly or Other Facilities

Educational, Institutional or Other Facility Type	Plan Review Required
Educational <sup>(2)(3)</sup>	YES
Institutional <sup>(2)(3)</sup>	YES
Places of assembly for 100 or more persons <sup>(1)</sup>	NO
Child day care center <sup>(1)</sup>	NO
School-age child care center <sup>(1)</sup>	NO
Family child day care home, family child care home, or child day care facility <sup>(1)</sup>	NO

**AMENDATORY SECTION** (Amending WSR 05-10-024, filed 4/26/05, effective 6/30/05)

**WAC 296-46B-020 General definitions.** (1) All definitions listed in the National Electrical Code and chapter 19.28 RCW are recognized in this chapter unless other specific definitions are given in this chapter.

(2) **"Accreditation"** is a determination by the department that a laboratory meets the requirements of this chapter and is therefore authorized to evaluate electrical products that are for sale in the state of Washington.

(3) **"Administrative law judge"** means an administrative law judge (ALJ) appointed pursuant to chapter 34.12 RCW and serving in board proceedings pursuant to chapter 19.28 RCW and this chapter.

(4) **"ANSI"** means American National Standards Institute. Copies of ANSI standards are available from the National Conference of States on Building Codes and Standards, Inc.

(5) **"Appeal"** is a request for review of a department action by the board as authorized by chapter 19.28 RCW.

(6) **"Appellant"** means any person, firm, partnership, corporation, or other entity that has filed an appeal or request for board review.

(7) **"Appliance"** means household appliance.

(8) **"ASTM"** means the American Society for Testing and Materials. Copies of ASTM documents are available from ASTM International.

~~((8))~~ (9) **"AWG"** means American Wire Gauge.

~~((9))~~ (10) **"Basement"** means that portion of a building that is partly or completely below grade plane. A basement shall be considered as a story above grade plane and not a basement where the finished surface of the floor above the basement is:

(a) More than 1829 mm (six feet) above grade plane;

(b) More than 1829 mm (six feet) above the finished ground level for more than 50% of the total building perimeter; or

(c) More than 3658 mm (twelve feet) above the finished ground level at any point.

Also see "mezzanine" and "story."

~~((10))~~ (11) **"Board"** means the electrical board established and authorized under chapter 19.28 RCW.

~~((11))~~ (12) **"Chapter"** means chapter 296-46B WAC unless expressly used for separate reference.

~~((12))~~ (13) **"Category list"** is a list of nonspecific product types determined by the department.

~~((13))~~ (14) A **"certified electrical product"** is an electrical product to which a laboratory, accredited by the state of Washington, has the laboratory's certification mark attached.

~~((14))~~ (15) A **"certification mark"** is a specified laboratory label, symbol, or other identifying mark that indicates the manufacturer produced the product in compliance with appropriate standards or that the product has been tested for specific end uses.

~~((15))~~ (16) **"Certificate of competency"** includes the certificates of competency for master journeyman electrician, master specialty electrician, journeyman, and specialty electrician.

~~((16))~~ (17) A laboratory **"certification program"** is a specified set of testing, inspection, and quality assurance procedures, including appropriate implementing authority, regulating the evaluation of electrical products for certification marking by an electrical products certification laboratory.

~~((17))~~ (18) A **"complete application"** includes the submission of all appropriate fees, documentation, and forms.

~~((18))~~ (19) **"Construction,"** for the purposes of chapter 19.28 RCW, means electrical construction.

~~((19))~~ (20) **"Coordination (selective)"** as defined in NEC 100 shall be determined and documented by a professional engineer registered under chapter 18.43 RCW.

(21) **"Department"** means the department of labor and industries of the state of Washington.

~~((20))~~ (22) **"Director"** means the director of the department, or the director's designee.

~~((21))~~ (23) **"Electrical equipment"** includes electrical conductors, conduit, raceway, apparatus, materials, components, and other electrical equipment not exempted by RCW 19.28.006(9). Any conduit/raceway of a type listed for electrical use is considered to be electrical equipment even if no wiring is installed in the conduit/raceway at the time of the conduit/raceway installation.

~~((22))~~ (24) An **"electrical products certification laboratory"** is a laboratory or firm accredited by the state of Washington to perform certification of electrical products.

~~((23))~~ (25) An **"electrical products evaluation laboratory"** is a laboratory or firm accredited by the state of Washington to perform on-site field evaluation of electrical products for safety.

~~((24))~~ (26) **"Field evaluated"** means an electrical product to which a field evaluation mark is attached. Field evaluation must include job site inspection unless waived by the department, and may include component sampling and/or laboratory testing.

~~((25))~~ (27) **"Field evaluation mark"** is a specified laboratory label, symbol, or other identifying mark indicating the manufacturer produced the product in essential compliance with appropriate standards or that the product has been evaluated for specific end uses.

~~((26))~~ (28) A **"field evaluation program"** is a specified set of testing, inspection, and quality assurance procedures, including appropriate implementing authority regulating the testing and evaluation of electrical products for field evaluation marking.

~~((27))~~ (29) The **"filing"** is the date the document is actually received in the office of the chief electrical inspector.

~~((28))~~ (30) **"Final judgment"** means any money that is owed to the department under this chapter, including fees and penalties, or any money that is owed to the department as a result of an individual's or contractor's unsuccessful appeal of a citation.

~~((29))~~ (31) **"Fished wiring"** is when cable or conduit is installed within the finished surfaces of an existing building or building structure (e.g., wall, floor or ceiling cavity).

~~((30))~~ (32) **"Household appliance"** means utilization equipment installed in a dwelling unit that is built in standardized sizes or types and is installed or connected as a unit to perform one or more functions such as cooking and other equipment installed in a kitchen, clothes drying, clothes washing, portable room air conditioning units and portable heaters, dish washing, water heating equipment supplying domestic potable water, etc. Fixed electric space-heating equipment covered in NEC 424 (furnaces, baseboard and wall heaters, electric heat cable, etc.) and fixed air-conditioning/heat pump equipment (NEC 440) are not household appliances. Household appliance does not mean any utilization equipment that:

(a) Supplies electrical power, other than Class 2, to other utilization equipment; or

(b) Receives electrical power, other than Class 2, through other utilization equipment.

**(33) HVAC/refrigeration specific definitions:**

(a) **"HVAC/refrigeration"** means heating, ventilation, air conditioning, and refrigeration.

(b) **"HVAC/refrigeration component"** means electrical power and limited energy components within the "HVAC/refrigeration system," including, but not limited to: Pumps, compressors, motors, heating coils, controls, switches, thermostats, humidistats, low-voltage damper controls, outdoor sensing controls, outside air dampers, stand-alone duct smoke detectors, air monitoring devices, zone control valves and equipment for monitoring of HVAC/

refrigeration control panels and low-voltage connections. This definition excludes equipment and components of non-"HVAC/refrigeration control systems."

(c) **"HVAC/refrigeration control panel"** means an enclosed, manufactured assembly of electrical components designed specifically for the control of a HVAC/refrigeration system. Line voltage equipment that has low voltage, NEC Class 2 control or monitoring components incidental to the designed purpose of the equipment is not an HVAC/refrigeration control panel (e.g., combination starters).

(d) **"HVAC/refrigeration control system"** means a network system regulating and/or monitoring a HVAC/refrigeration system. Equipment of a HVAC/refrigeration control system includes, but is not limited to: Control panels, data centers, relays, contactors, sensors, and cables related to the monitoring and control of a HVAC/refrigeration system(s).

(e) **"HVAC/refrigeration equipment"** means the central unit primary to the function of the "HVAC/refrigeration system." HVAC/refrigeration includes, but is not limited to: Heat pumps, swamp coolers, furnaces, compressor packages, and boilers.

(f) **"HVAC/refrigeration system"** means a system of HVAC/refrigeration: Wiring, equipment, and components integrated to generate, deliver, or control heated, cooled, filtered, refrigerated, or conditioned air. This definition excludes non-HVAC/refrigeration control systems (e.g., fire alarm systems, intercom systems, building energy management systems, and similar non-HVAC/refrigeration systems) (see Figure 920-1 and Figure 920-2).

~~((31))~~ (34) **"IBC"** means the International Building Code. Copies of the IBC are available from the International Code Council.

~~((32))~~ (35) An **"individual"** or **"party"** or **"person"** means an individual, firm, partnership, corporation, association, government subdivision or unit thereof, or other entity.

~~((33))~~ (36) An **"installation"** includes the act of installing, connecting, repairing, modifying, or otherwise performing work on an electrical system, component, equipment, or wire except as exempted by WAC 296-46B-925.

~~((34))~~ (37) An **"identification plate"** is a phenolic or metallic plate or other similar material engraved in block letters at least 1/4" (6 mm) high unless specifically required to be larger by this chapter, suitable for the environment and application. The letters and the background must be in contrasting colors. Screws, rivets, or methods specifically described in this chapter must be used to affix an identification plate to the equipment or enclosure.

~~((35))~~ (38) **"License"** means a license required under chapter 19.28 RCW.

~~((36))~~ (39) **"Labeled"** means an electrical product that bears a certification mark issued by a laboratory accredited by the state of Washington.

~~((37))~~ (40) A **"laboratory"** may be either an electrical product(s) certification laboratory or an electrical product(s) evaluation laboratory.

~~((38))~~ (41) A **"laboratory operations control manual"** is a document to establish laboratory operation procedures and may include a laboratory quality control manual.



~~((39))~~ (42) **"Like-in-kind"** means having similar characteristics such as voltage requirement, current draw, circuit overcurrent and short circuit characteristics, and function within the system and being in the same location. Like-in-kind also includes any equipment component authorized by the manufacturer as a suitable component replacement part.

~~((40))~~ (43) **"Lineman"** is a person employed by a serving electrical utility or employed by a licensed general electrical contractor who carries, on their person, evidence that they:

(a) Have graduated from a department-approved lineman's apprenticeship course; or

(b) Are currently registered in a department-approved lineman's apprenticeship course and are working under the direct one hundred percent supervision of a journeyman electrician or a graduate of a lineman's apprenticeship course approved by the department. The training received in the lineman's apprenticeship program must include training in applicable articles of the currently adopted National Electrical Code.

~~((41))~~ (44) **"Listed"** means equipment has been listed and identified by a laboratory approved by the state of Washington for the appropriate equipment standard per this chapter.

~~((42))~~ (45) **"Low voltage"** means:

(a) NEC, Class 1 power limited circuits at 30 volts maximum.

(b) NEC, Class 2 circuits powered by a Class 2 power supply as defined in NEC 725.41(A).

(c) NEC, Class 3 circuits powered by a Class 3 power supply as defined in NEC 725.41(A).

(d) Circuits of telecommunications systems as defined in chapter 19.28 RCW.

~~((43))~~ (46) **"Mezzanine"** is the intermediate level or levels between the floor and ceiling of any story with an aggregate floor area of not more than one-third of the area of the room or space in which the level or levels are located. Also see "basement" and "story."

~~((44))~~ (47) **"NEC"** means National Electrical Code. Copies of the NEC are available from the National Fire Protection Association.

~~((45))~~ (48) **"NEMA"** means National Electrical Manufacturer's Association. Copies of NEMA standards are available from the National Electrical Manufacturer's Association.

~~((46))~~ (49) **"NESC"** means National Electrical Safety Code. Copies of the NESC are available from the Institute of Electrical and Electronics Engineers, Inc.

~~((47))~~ (50) **"NETA"** means International Electrical Testing Association, Inc. Copies of the NETA standards and information are available from the International Electrical Testing Association, Inc.

~~((48))~~ (51) **"NFPA"** means the National Fire Protection Association. Copies of NFPA documents are available from the National Fire Protection Association.

~~((49))~~ (52) **"NRTL"** means Nationally Recognized Testing Laboratory accredited by the federal Occupational Safety and Health Administration (OSHA) after meeting the requirements of 29 CFR 1910.7.

~~((50))~~ (53) **"Point of contact"** for utility work, means the point at which a customer's electrical system connects to the serving utility system.

~~((51))~~ (54) **"Proceeding"** means any matter regarding an appeal before the board including hearings before an administrative law judge.

~~((52))~~ (55) **"Public area or square"** is an area where the public has general, clear, and unrestricted access.

~~((53))~~ (56) A **"quality control manual"** is a document to maintain the quality control of the laboratory's method of operation. It consists of specified procedures and information for each test method responding to the requirements of the product standard. Specific information must be provided for portions of individual test methods when needed to comply with the standard's criteria or otherwise support the laboratory's operation.

~~((54))~~ (57) **"RCW"** means the Revised Code of Washington. Copies of electrical RCWs are available from the department and the office of the code reviser.

~~((55))~~ (58) A **"stand-alone amplified sound or public address system"** is a system that has distinct wiring and equipment for audio signal generation, recording, processing, amplification, and reproduction. This definition does not apply to telecommunications installations.

~~((56))~~ (59) **"Service"** or **"served"** means that as defined in RCW 34.05.010(19) when used in relation to department actions or proceedings.

~~((57))~~ (60) **"Story"** is that portion of a building included between the upper surface of a floor and the upper surface of the floor or roof next above. Next above means vertically and not necessarily directly above. Also see "basement" and "mezzanine."

~~((58))~~ (61) **"Structure,"** for the purposes of this chapter and in addition to the definition in the NEC, means something constructed either in the field or factory that is used or intended for supporting or sheltering any use or occupancy as defined by the IBC.

~~((59))~~ (62) A **"telecommunications local service provider"** is a regulated or unregulated (e.g., by the Federal Communications Commission or the utilities and transportation commission as a telephone or telecommunications provider) firm providing telecommunications service ahead of the telecommunications network demarcation point to an end-user's facilities.

~~((60))~~ (63) **"Telecommunications network demarcation point"** is as defined in RCW 19.28.400 for both regulated carriers and unregulated local service providers.

~~((61))~~ (64) **"TIA/EIA"** means the Telecommunications Industries Association/Electronic Industries Association which publishes the *TIA/EIA Telecommunications Building Wiring Standards*. Standards and publications are adopted by TIA/EIA in accordance with the American National Standards Institute (ANSI) patent policy.

~~((62))~~ (65) A **"training school"** is a public community or technical college or not-for-profit nationally accredited technical or trade school licensed by the work force training and education coordinating board under chapter 28C.10 RCW.

~~((63))~~ (66) **"Under the control of a utility"** for the purposes of RCW 19.28.091 and 19.28.101 is when electrical equipment is not owned by a utility and:

(a) Is located in a vault, room, closet, or similar enclosure that is secured by a lock or seal so that access is restricted to the utility's personnel; or

(b) The utility is obligated by contract to maintain the equipment and the contract provides that access to the equipment is restricted to the utility's personnel or other qualified personnel.

~~((64))~~ (67) **"UL"** means Underwriters Laboratory.

~~((65))~~ (68) **"Utility"** means an electrical utility.

~~((66))~~ (69) **"Utility system"** means electrical equipment owned by or under the control of a serving utility that is used for the transmission or distribution of electricity from the source of supply to the point of contact.

~~((67))~~ (70) **"Utilization voltage"** means the voltage level employed by the utility's customer for connection to lighting fixtures, motors, heaters, or other electrically operated equipment other than power transformers.

~~((68))~~ (71) **"Variance"** is a modification of the electrical requirements as adopted in chapter 19.28 RCW or any other requirements of this chapter that may be approved by the chief electrical inspector if assured that equivalent objectives can be achieved by establishing and maintaining effective safety.

~~((69))~~ (72) **"WAC"** means the Washington Administrative Code. Copies of this chapter of the WACs are available from the department and the office of the code reviser.

**AMENDATORY SECTION** (Amending WSR 05-22-025, filed 10/25/05, effective 11/25/05)

**WAC 296-46B-030 Industrial control panel and industrial utilization equipment inspection. Specific definitions.**

(1) Specific definitions for this section:

(a) **"Department evaluation"** means a review in accordance with subsection (2)(c) of this section.

(b) **"Engineering evaluation"** means a review in accordance with subsection (2)(d) of this section.

(c) **"Food processing plants"** include buildings or facilities used in a manufacturing process, but do not include:

- (i) Municipal or other government facilities;
- (ii) Educational facilities or portions thereof;
- (iii) Institutional facilities or portions thereof;
- (iv) Restaurants;
- (v) Farming, ranching, or dairy farming operations;
- (vi) Residential uses; or
- (vii) Other installations not used for direct manufacturing purposes.

~~((e))~~ (d) In RCW 19.28.010, **"industrial control panel"** means a factory or user wired assembly of industrial control equipment such as motor controllers, switches, relays, power supplies, computers, cathode ray tubes, transducers, and auxiliary devices used in the manufacturing process to control industrial utilization equipment. The panel may include disconnecting means and motor branch circuit protective devices. Industrial control panels include only

those used in a manufacturing process in a food processing or industrial plant.

~~((f))~~ (e) **"Industrial plants"** include buildings or facilities used in a manufacturing process or a manufacturing training facility (e.g., educational shop area in an educational or institutional facility), but do not include:

- (i) Municipal or other government facilities;
- (ii) Other educational facilities or portions thereof;
- (iii) Other institutional facilities or portions thereof;
- (iv) Restaurants;
- (v) Farming, ranching, or dairy farming operations;
- (vi) Residential uses; or
- (vii) Other installations not used for direct manufacturing purposes.

~~((g))~~ (f) **"Industrial utilization equipment"** means equipment directly used in a manufacturing process in a food processing or industrial plant, in particular the processing, treatment, moving, or packaging of a material. Industrial utilization equipment does not include: Cold storage, warehousing, or similar storage equipment.

~~((h))~~ (g) **"Manufacturing process"** means to make or process a raw material or part into a finished product for sale using industrial utilization equipment. A manufacturing process does not include the storage of a product for future distribution (e.g., cold storage, warehousing, and similar storage activity).

~~((i))~~ (h) **"Normal department inspection"** is a part of the department electrical inspection process included with the general wiring inspection of a building, structure, or other electrical installation. Normal department inspection will only be made for equipment solely using listed or field evaluated components and wired to the requirements of the NEC. Fees for the normal department inspections required under this chapter are included in the electrical work permit fee calculated for the installation and are not a separate inspection fee. However, inspection time associated with such equipment is subject to the progress inspection rates in WAC 296-46B-905.

~~((j))~~ (i) For the purposes of this section, **"panel"** means a single box or enclosure containing the components comprising an industrial control panel. A panel does not include any wiring methods connecting multiple panels or connecting a panel(s) and other electrical equipment.

**Safety standards.**

(2) Industrial control panels and industrial utilization equipment will be determined to meet the minimum electrical safety standards for installations by:

(a) Listing, or field evaluation of the entire panel or equipment;

(b) Normal department inspection for compliance with codes and rules adopted under this chapter; or

(c) ~~((k))~~ Until December 31, 2006, department evaluation showing compliance with appropriate standards. Appropriate standards are NEMA, ANSI, NFPA 79, UL 508A ~~((l))~~, International Electrotechnical Commission 60204, or their equivalent. Industrial utilization equipment is required to conform to a nationally or internationally recognized standard applicable for the particular industrial utilization equipment. Compliance must be shown as follows:

(i) The equipment's manufacturer must document, by letter to the equipment owner, the equipment's conformity to an appropriate standard(s). The letter must state:

- (A) The equipment manufacturer's name;
- (B) The type of equipment;
- (C) The equipment model number;
- (D) The equipment serial number;
- (E) The equipment supply voltage, amperes, phasing;
- (F) The standard(s) used to manufacture the equipment.

Except for the reference of construction requirements to ensure the product can be installed in accordance with the National Electrical Code, the National Electrical Code is not considered a standard for the purposes of this section;

(G) Fault current interrupting rating of the equipment or the owner may provide documentation showing that the fault current available at the point where the building wiring connects to the equipment is less than 5,000 AIC; and

(H) The date the equipment was manufactured. Equipment that was manufactured prior to January 1, 1985, is not required to meet (c)(i)(F) of this subsection.

(ii) The equipment owner must document, by letter to the chief electrical inspector, the equipment's usage as industrial utilization equipment as described in this section and provide a copy of the equipment manufacturer's letter described in (c)(i) of this subsection. The owner's letter must be accompanied by the fee required in WAC 296-46B-905(14).

For the purposes of this section, the owner must be a food processing or industrial plant as described in this section.

(iii) The chief electrical inspector will evaluate the equipment manufacturer's letter, equipment owner's letter, and the individual equipment.

If the equipment is determined to have had electrical modifications since the date of manufacture, the chief electrical inspector will not approve equipment using this method.

(iv) If required by the chief electrical inspector, the owner must provide the department with a copy, in English, of the standard(s) used and any documentation required by the chief electrical inspector to support the claims made in the equipment manufacturer's or owner's letter. At the request of the owner, the department will obtain a copy of any necessary standard to complete the review. If, per the owner's request, the department obtains the copy of the standard, the owner will be billed for all costs associated with obtaining the standard.

If the industrial utilization equipment has been determined to be manufactured to a standard(s) appropriate for industrial utilization equipment as determined by the chief electrical inspector per RCW 19.28.010(1), the equipment will be marked with a department label.

The department will charge a marking fee as required in WAC 296-46B-905(14). Once marked by the department, the equipment is suitable for installation anywhere within the state without modification so long as the equipment is being used as industrial utilization equipment. If payment for marking is not received by the department within thirty days of marking the equipment, the department's mark(s) will be removed and the equipment ordered removed from service.

(v) If the equipment usage is changed to other than industrial utilization equipment or electrical modifications

are made to the equipment, the equipment must be successfully listed or field evaluated by a laboratory approved by the department.

(vi) The equipment must be permanently installed at the owner's facility and inspected per the requirements of RCW 19.28.101.

(d) An engineering evaluation where an engineer accredited by the department, shows the equipment to be in compliance with appropriate standards. See WAC 296-46B-997 for the requirements to become an accredited engineer. Appropriate standards are NEMA, ANSI, NFPA 79, UL 508A, International Electrotechnical Commission 60204, or their equivalent. Industrial utilization equipment is required to conform to a nationally or internationally recognized standard applicable for the particular industrial utilization equipment. At a minimum, compliance must be shown as follows:

(i) The engineer must document, by letter to the chief electrical inspector, the equipment's conformity to an appropriate standard(s) and the fault current interrupting rating of the equipment. The National Electrical Code is not considered a standard for the purposes of this section.

(ii) The engineer must affix a permanent label to the equipment showing:

(A) Engineer's name;

(B) Date of approval;

(C) Equipment serial number; and

(D) The following statement: "This equipment meets appropriate standards for industrial utilization equipment."

(3) The department may authorize, on a case-by-case basis, use of the industrial control panel or equipment, for a period not to exceed six months or as approved by the chief electrical inspector after use is begun, before its final inspection, listing, or evaluation.

AMENDATORY SECTION (Amending WSR 03-09-111, filed 4/22/03, effective 5/23/03)

**WAC 296-46B-040 Traffic management systems. (1)**

The department will perform the electrical inspection and acceptance of traffic management systems within its jurisdiction. A traffic management system includes:

(a) Traffic illumination systems;

(b) Traffic signal systems;

(c) Traffic monitoring systems; ~~(and)~~

(d) The electrical service cabinet and all related components and equipment installed on the load side of the service cabinet supplying electrical power to the traffic management system; and

(e) Signalization system(s) necessary for the operation of a light rail system.

A traffic management system can provide signalization for controlling vehicular traffic, pedestrian traffic, or rolling stock.

(2) The department recognizes that traffic signal conductors, pole and bracket cables, signal displays, and traffic signal controllers/cabinets and associated components used in traffic management systems are acceptable for the purpose of meeting the requirements of chapter 19.28 RCW provided they conform with the following standards or are listed on the

Washington state department of transportation (WSDOT) qualified products list.

- (a) WSDOT/APWA Standard Specifications and Plans;
- (b) WSDOT Design Manual;
- (c) International Municipal Signal Association (IMSA);
- (d) National Electrical Manufacturer's Association (NEMA);
- (e) Federal Standards 170/Controller Cabinets;
- (f) Manual for Uniform Road, Bridge, and Municipal Construction;
- (g) Institute of Transportation Engineers (ITE); or
- (h) Manual of Uniform Traffic Control Devices (MUTCD).

(3) Associated induction detection loop or similar circuits will be accepted by the department without inspection.

(4) For the licensing requirements of chapter 19.28 RCW, jurisdictions will be considered owners of traffic management systems when doing electrical work for other jurisdiction(s) under a valid interlocal agreement, as permitted by chapter 39.34 RCW. Interlocal agreements for traffic management systems must be filed with the department prior to work being performed for this provision to apply.

(5) Jurisdictions, with an established electrical inspection authority, and WSDOT may perform electrical inspection on their rights of way for each other by interlocal agreement. They may not perform electrical inspection on other rights of way except as allowed in chapter 19.28 or 39.34 RCW.

(6) Underground installations.

(a) In other than open trenching, raceways will be considered "fished" according to the NEC and do not require visual inspection.

(b) The department will conduct inspections in open trenching within its jurisdiction. The electrical work permit purchaser must coordinate the electrical inspection. A written request (e.g., letter, e-mail, fax, etc.) for inspection, made to the department office having the responsibility to perform the inspection, must be made a minimum of two working days prior to the day inspection is needed (e.g., two working days - 10:00 a.m. Tuesday request for a 10:00 a.m. Thursday inspection, excluding holidays and weekends).

If, after proper written request, the department fails to make an electrical inspection at the time requested, underground conduit may be covered after inspection by the local government jurisdiction's project inspector/designee. Written documentation of a local government jurisdiction inspection must be provided to the department when requested. Written documentation will include:

- (i) Date and time of inspection;
- (ii) Location;
- (iii) Installing firm;
- (iv) Owner;
- (v) Type of conduit;
- (vi) Size of conduit;
- (vii) Depth of conduit; and
- (viii) Project inspector/designee name and contact information.

(7) Identification of traffic management system components. Local government jurisdictions or WSDOT may act as

the certifying authority for the safety evaluation of all components.

(a) An electrical service cabinet must contain only listed components. The electrical service cabinet enclosure is not required to be listed but will conform to the standards in subsection (2) of this section.

(b) The local government jurisdiction must identify, as acceptable, the controller cabinet or system component(s) with an identification plate. The identification plate must be located inside the cabinet and may be attached with adhesive.

(8) Conductors of different circuits in same cable, enclosure, or raceway. All traffic management system circuits will be permitted to occupy the same cable, enclosure, or raceway without regard to voltage characteristics, provided all conductors are insulated for the maximum voltage of any conductor in the cable, enclosure, or raceway.

AMENDATORY SECTION (Amending WSR 05-22-025, filed 10/25/05, effective 11/25/05)

**WAC 296-46B-110 General—Requirements for electrical installations.**

**012 Mechanical execution of work.**

(1) Unused openings. Unused openings in boxes, raceways, auxiliary gutters, cabinets, cutout boxes, meter socket enclosures, equipment cases, or housings shall be effectively closed to afford protection substantially equivalent to the wall of the equipment. Where metallic plugs or plates are used with nonmetallic enclosures, they shall be recessed at least 6 mm (1/4") from the outer surface of the enclosure. Unused openings do not include weep holes, unused mounting holes, or any other opening with less than .15 square inches of open area.

**016 Flash protection.**

(2) The flash protection marking required by NEC 110.16 must be an identification plate or label approved by the electrical inspector and may be installed either in the field or in the factory. The plate or label may be mounted using adhesive.

**022 Identification of disconnecting means.**

(3) For the purposes of legibly marking a disconnecting means, as required in NEC 110.22, an identification plate is required unless the disconnect is a circuit breaker/fused switch installed within a panelboard and the circuit breaker/fused switch is identified by a panelboard schedule. In other than dwelling units, the identification plate must include the identification designation of the circuit source panelboard that supplies the disconnect.

(4) Where electrical equipment is installed to obtain a series combination rating, the identification as required by NEC 110.22, must be in the form of an identification plate that is substantially yellow in color. The words "**CAUTION - SERIES COMBINATION RATED SYSTEM**" must be on the label in letters at least 13 mm (1/2") high.

**030 Over 600 volts - general.**

(5) Each cable operating at over 600 volts and installed on customer-owned systems must be legibly marked in a permanent manner at each termination point and at each point the cable is accessible. The required marking must use phase

designation, operating voltage, and circuit number if applicable.

(6) Only licensed electrical contractors can use the Class B basic electrical inspection - random inspection process. Health care, large commercial, or industrial facilities using an employee who is a certified electrician(s) can use the Class B basic electrical inspection - random inspection process after permission from the chief electrical inspector.

(7) If the Class B basic electrical inspection - random inspection process is used, the following requirements must be met:

(a) The certified electrician/telecommunications worker performing the installation must affix a Class B installation label on the cover of the panelboard or overcurrent device supplying power to the circuit or equipment prior to beginning the work.

(b) The job site portion of the label must include the following:

(i) Date of the work;

(ii) Electrical/telecommunication contractor's name;

(iii) Electrical/telecommunication contractor's license number;

(iv) Installing electrician's certificate number, except for telecommunication work; and

(v) Short description of the work.

(c) The contractor portion of the label must include the following:

(i) Date of the work;

(ii) Electrical/telecommunication contractor's license number;

(iii) Installing electrician's certificate number, except for telecommunication work;

(iv) Job site address;

(v) Contact telephone number for the job site (to be used to arrange inspection); and

(vi) Short description of the work.

(d) The label must be filled in using sunlight and weather resistant ink.

(e) The electrical/telecommunication contractor must return the contractor's portion of the label to the Department of Labor & Industries, Electrical Section, Chief Electrical Inspector, P.O. 4460, Olympia, WA 98506-4460 within fifteen working days after the job site portion of the Class B installation label is affixed.

(8) Class B basic installation labels will be sold in blocks. Installations where a Class B basic installation label is used will be inspected on a random basis as determined by the department.

(a) If any such random inspection fails, a subsequent ~~((installation))~~ label in the block must be inspected.

(b) If any such subsequent installation fails inspection, ~~((all installations))~~ another label in the block must be inspected until a label is approved without a correction(s).

(9) Any electrical/telecommunication contractor or other entity using the Class B basic electrical inspection - random inspection process may be audited for compliance with the provisions for purchasing, inspection, reporting of installations, and any other requirement of usage.

(10) Class B basic electrical work means work other than Class A basic electrical work. See WAC 296-46B-900(8) for

Class A definition. ~~((A cover inspection is required for all fire-wall penetrations:))~~

(a) Class B basic electrical work includes the following:

(i) Extension of not more than one branch electrical circuit limited to one hundred twenty volts and twenty amps each where:

(A) No cover inspection is necessary; and

(B) The extension does not supply more than two devices or outlets as defined by the NEC. A device allowed in an extended circuit includes: General use snap switches/receptacles, luminaires, thermostats, speakers, etc., but does not include wiring/cabling systems, isolating switches, magnetic contactors, motor controllers, etc.

(ii) Like-in-kind replacement of:

(A) A single luminaire not exceeding two hundred seventy-seven volts and twenty amps; or

(B) A motor larger than ten horsepower; or

(C) The internal wiring of a furnace, air conditioner, refrigeration unit or household appliance; or

(D) An electric/gas/oil furnace not exceeding 240 volts and 100 amps when the furnace is connected to an existing branch circuit. For the purposes of this section, a boiler is not a furnace; or

(E) An individually controlled electric room heater (e.g., baseboard, wall, fan forced air, etc.), air conditioning unit or refrigeration unit not exceeding 240 volts, 30 minimum circuit amps when the unit is connected to an existing branch circuit; or

(F) Circuit modification required to install not more than five residential load control devices in a residence where installed as part of an energy conservation program sponsored by an electrical utility and where the circuit does not exceed 240 volts and 30 amps.

(iii) The following low voltage systems:

(A) Repair and replacement of devices not exceeding one hundred volt-amperes in Class 2, Class 3, or power limited low voltage systems in one- and two-family dwellings; or

(B) Repair and replacement of devices not exceeding one hundred volt-amperes in Class 2, Class 3, or power limited low voltage systems in other buildings, provided the equipment is not for fire alarm or nurse call systems and is not located in an area classified as hazardous by the NEC((-)); or

(C) The installation of device(s) or wiring for Class 2 or 3 thermostat, audio, security, burglar alarm, intercom, amplified sound, public address, or access control systems. This does not include fire alarm, nurse call, lighting control, industrial automation/control or energy management systems; or

(D) Telecommunications cabling and equipment requiring inspection in RCW 19.28.470;

(iv) The replacement of not more than ten standard receptacles with GFCI receptacles;

(v) The conversion of not more than ten snap switches to dimmers for the use of controlling a luminaire(s) conversion.

(b) Class B basic electrical work does not include any work in:

(i) Areas classified as Class ((+)) (I), Class ((2)) (II), Class ((3)) (III), or Zone locations per NEC 500; or

(ii) Areas regulated by NEC 517 or 680; or

- (iii) Any work where electrical plan review is required; or
- (iv) Fire alarm, nurse call, lighting control, industrial automation/control or energy management systems.

**AMENDATORY SECTION** (Amending WSR 05-10-024, filed 4/26/05, effective 6/30/05)

**WAC 296-46B-210 Wiring and protection—Branch circuits. 008B Other than dwelling units - GFCI requirements.**

(1) GFCI requirements.

~~((a))~~ All 125-volt, 15- and 20-ampere receptacles installed in wet locations must have Class A ground-fault circuit interrupter protections for personnel.

~~((b) Kitchens in other than dwelling units are considered to be any work surface where food and/or beverage preparation occurs and other countertops or islands.)~~

**011 Branch circuits.**

(2) Circuits must be taken to all unfinished spaces adaptable to future dwelling unit living areas that are not readily accessible to the service or branch circuit panelboard. The circuits must terminate in a suitable box(es). The box must contain an identification of the intended purpose of the circuit(s). The branch circuit panelboard must have adequate space and capacity for the intended load(s).

**012 Arc-fault circuit-interrupter protection.**

(3) For the purpose of NEC 210.12(B), Dwelling Unit Bedroom spaces that:

- (a) Are accessed only through the bedroom;
- (b) Are ancillary to the bedroom's function; and
- (c) Contain branch circuits that supply 125-volt, 15- and 20-ampere, outlets must be protected by an arc-fault circuit interrupter listed to provide protection per NEC 210.12.

For the purposes of this section, such spaces will include, but not be limited to, spaces such as closets and sitting areas, but will not include bathrooms.

**051(B)(5) Receptacle outlet locations.**

(4) Receptacle outlets installed in appliance garages may be counted as a required countertop outlet.

**052(A)(2) Dwelling unit receptacle outlets.**

(5) For the purpose of NEC 210.52(A)(2)(1), "similar openings" include the following configurations that are a permanent part of the dwelling configuration or finish:

- (a) Window seating; and
- (b) Bookcases or cabinets that extend from the floor to a level at least 1.7 meters (five (5) feet six (6) inches) above the floor.

Any outlets eliminated by such window seating, bookcases, or cabinets must be installed elsewhere within the room.

**052(C) Countertops.**

(6) A receptacle(s) is not required to be installed in the area directly behind a sink or range as shown in NEC 210.52, Figure 210.52. Outlets must be installed within 24" on either side of a sink or range as shown in Figure 210.52.

(7) A receptacle is not required on any peninsular counter surface as required by NEC 210.52(C)(3) so long as the peninsular counter area extends no farther than 6' from the face of the adjoining countertop. Any outlet(s) eliminated

using this subsection must be installed in the wall space directly opposite the point where the peninsula connects to the wall countertop in addition to the outlets required by NEC 210.52(C)(1).

**AMENDATORY SECTION** (Amending WSR 05-10-024, filed 4/26/05, effective 6/30/05)

**WAC 296-46B-250 Wiring and protection—Grounding and bonding.**

**032 Two or more buildings or structures.**

(1) Effective August 1, 2003, an equipment grounding conductor must be installed with the circuit conductors between buildings and/or structures. A grounded conductor (i.e., neutral) is not permitted to be used in place of a separate equipment grounding conductor between buildings and/or structures.

**052 Grounding electrodes.**

(2) If a ground resistance test is not performed to ensure a resistance to ground of twenty-five ohms or less, two or more electrodes as specified in NEC 250.52 must be installed a minimum of six feet apart. However, a temporary construction service is not required to have more than one made electrode.

**090 Bonding.**

(3) Metallic stubs or valves used in nonmetallic plumbing systems are not required to be bonded to the electrical system unless required by an electrical equipment manufacturer's instructions.

(4) Hot and cold water plumbing lines are not required to be bonded together if, at the time of inspection, the inspector can determine the lines are mechanically and electrically joined by one or more metallic mixing valves.

**184 Solidly grounded neutral systems over 1 kV.**

(5) In addition to the requirements of NEC 250.184(A), the following applies for:

(a) Existing installations.

(i) The use of a concentric shield will be allowed for use as a neutral conductor for extension, replacement, or repair, if all of the following are complied with:

(A) The existing system uses the concentric shield as a neutral conductor;

(B) Each individual conductor contains a separate concentric shield sized to no less than thirty-three and one-half percent of the ampacity of the phase conductor for three-phase systems or one hundred percent of the ampacity of the phase conductor for single-phase systems;

(C) The new or replacement cable's concentric shield is enclosed inside an outer insulating jacket; and

(D) Existing cable (i.e., existing cable installed directly in the circuit between the work and the circuit's overcurrent device) successfully passes the following tests:

- A cable maintenance high potential dielectric test. The test must be performed in accordance with the cable manufacturer's instruction or the 2001 NETA maintenance test specifications; and

- A resistance test of the cable shield. Resistance must be based on the type, size, and length of the conductor used as the cable shield using the conductor properties described in NEC Table 8 Conductor Properties.

An electrical engineer must provide a specific certification to the electrical plan review supervisor in writing that the test results of the maintenance high potential dielectric test and the resistance test have been reviewed by the electrical engineer and that the cable shield is appropriate for the installation. The electrical engineer must stamp the certification document with the engineer's stamp and signature. The document may be in the form of a letter or electrical plans.

Testing results are valid for a period of seven years from the date of testing. Cable will not be required to be tested at a shorter interval.

(ii) A concentric shield used as a neutral conductor in a multigrounded system fulfills the requirements of an equipment grounding conductor.

(b) New installations.

(i) New installations do not include extensions of existing circuits.

(ii) The use of the concentric shield will not be allowed for use as a neutral conductor for new installations. A listed separate neutral conductor meeting the requirements of NEC 250.184(A) must be installed.

~~((6) Multiple grounding. NEC 250.184 (c)(1) is replaced with the following:~~

~~The neutral of a solidly grounded neutral system may be grounded at more than one point.~~

~~(a) Multiple grounding is permitted at the following locations:~~

~~(i) Services;~~

~~(ii) Underground circuits where the neutral is exposed; and~~

~~(iii) Overhead circuits installed outdoors.~~

~~(b) Multiple grounding is not allowed:~~

~~(i) For new systems where singlepoint and multigrounded circuits form a single system (e.g., where a singlepoint circuit is derived from a multigrounded circuit); or~~

~~(ii) In new single phase (i.e., single phase to ground) installations.~~

~~(7) Multigrounded neutral conductor. NEC 250.184 (C)(2) through (5) is replaced with the following:~~

~~Where a multigrounded neutral system is used, the following will apply for new balanced phase to phase circuits and extensions, additions, replacements; and repairs to all existing systems of 1 kV and over:~~

~~(a) For existing systems:~~

~~(i) The cable's concentric shield must be used as the neutral and all the requirements for neutral conductors described in subsection (6) of this section must be met; or~~

~~(ii) The cable's concentric shield must be effectively grounded to a separate bare copper neutral conductor at all locations where the shield is exposed to personnel contact.~~

~~(b) For new systems:~~

~~A separate copper neutral must be installed and the cable's concentric shield is effectively grounded to the separate neutral at all locations where the shield is exposed to personnel contact.~~

~~(c) In addition to (a) and (b) of this subsection, the following is required:~~

~~(i) A minimum of two made electrodes, separated by at least six feet, must be installed at each existing and new trans-~~

~~former and switching/overcurrent location and connected to the neutral conductor at that location;~~

~~(ii) At least one grounding electrode must be installed and connected to the multigrounded neutral every 400 m (1,300'). The maximum distance between adjacent electrodes must not be more than 400 m (1,300');~~

~~(iii) In a multigrounded shielded cable system, the shielding must be grounded at each cable joint that is exposed to personnel contact;~~

~~(iv) All exposed noncurrent carrying metal parts (e.g., mounting brackets, manhole covers, equipment enclosures; etc.) must be effectively grounded to the neutral conductor; and~~

~~(v) An electrical engineer must provide a specific certification to the electrical plan review supervisor in writing that the design of the multiple grounding installation has been reviewed by the electrical engineer and the design is in accordance with the requirements of chapter 19.28 RCW, this chapter, and normal standards of care. The electrical engineer must stamp the certification document with the engineer's stamp and signature. The document may be in the form of a letter or electrical plans.))~~

AMENDATORY SECTION (Amending WSR 03-09-111, filed 4/22/03, effective 5/23/03)

**WAC 296-46B-501 Special occupancies NEC Class (4) I locations.**

**001 Sewage disposal systems.**

(1) Pumping chambers for sewage, effluent, or grinder pumps in on-site and septic tank effluent pump (S.T.E.P.) disposal systems will be considered unclassified when not more than five residential units are connected to the system, residential units are connected to a utility sewage system, or when nonresidential systems have residential loading characteristics and all of the following general installations requirements are complied with:

(a) The pumping chamber must be adequately vented. Venting may be accomplished through the building or structure plumbing vents where the system venting has been approved by the local jurisdiction authority or by a direct two-inch minimum vent to the atmosphere;

(b) Equipment that in normal operation may cause an arc or spark must not be installed in any pumping chamber;

(c) Float switches installed in a pumping chamber must be hermetically sealed to prevent the entrance of gases or vapors;

(d) Junction boxes, conduits and fittings installed in the septic atmosphere must be of a noncorrosive type, installed to prevent the entrance of gases or vapors;

(e) Where a conduit system is installed between the pumping chamber and the control panel, motor disconnect, or power source, an approved sealing method must be installed to prevent the migration of gases or vapors from the pumping chamber, and must remain accessible; and

(f) Wire splices in junction boxes installed in pumping chambers must be suitable for wet locations.

(2) Residential wastewater loading characteristics in a nonresidential installation:

(a) For systems that process less than three thousand five hundred gallons of wastewater per day may be certified by:

(i) An on-site wastewater designer licensed under chapter 18.210 RCW; or

(ii) A professional engineer, engaged in the business of on-site wastewater system design, licensed under chapter 18.43 RCW.

(b) For systems that process three thousand five hundred gallons or more of wastewater per day may be certified by a professional engineer, engaged in the business of on-site wastewater system design, licensed under chapter 18.43 RCW.

Written documentation must be signed and stamped by the designer or engineer and provided to the electrical inspector prior to inspection.

(3) Any residential or nonresidential system that has building or structure floor drains being discharged into the system is classified as Class I Division ((#)) 1. Drains from any commercially made tub, shower, basin, sink, or toilet are not considered floor drains.

(4) Pumping chamber access covers can be covered by gravel, light aggregate, or noncohesive granulated soil, and must be accessible for excavation. Access covers that are buried must have their exact location identified at the electrical panel or other prominent location by an identification plate. The authority having jurisdiction for performing electrical inspections must approve the identification plate location.

(5) Indoor grinder pumps installed in chambers with less than fifty gallons capacity are not required to meet the requirements of this section, except for the venting requirements in subsection (1)(a) of this section. Indoor grinder pumps installed in chambers with less than fifty gallons capacity are not classified systems as described in Article 500 NEC.

(6) Secondary treatment effluent pumping chambers such as sand filters are unclassified, and require no special wiring methods.

(7) Inspection approval is required prior to covering or concealing any portion of the septic electrical system, including the pump. New septic and effluent tanks containing electrical wires and equipment must be inspected and approved prior to being loaded with sewage.

**AMENDATORY SECTION** (Amending WSR 03-09-111, filed 4/22/03, effective 5/23/03)

**WAC 296-46B-555 Special occupancies—Marinas and boatyards.** (1) For the purposes of NEC 555.1, the scope of work includes private, noncommercial docking facilities.

(2) For the purposes of NEC 555.5, transformer((s)) terminations must be located a minimum of twelve inches above the deck of a dock (datum plane requirements do not apply for this section).

(3) For the purposes of NEC 555.7, adjacent means within sight.

(4) For the purposes of NEC 555.9, all electrical connections must be installed a minimum of twelve inches above the deck of a pier unless the connections are approved for wet locations (datum plane requirements do not apply for this section).

(5) For the purposes of NEC 555.10, all enclosures must be corrosion resistant. All gasketed enclosures must be arranged with a weep hole to discharge condensation.

(6) For the purposes of NEC 555.11, gasketed enclosures are only required for wet locations.

(7) For the purposes of NEC 555.13, the following wiring methods are allowed:

(a) All wiring installed in a damp or wet location must be suitable for wet locations.

(b) Extra-hard usage portable power cables rated not less than 75°C, 600 volts, listed for wet locations and sunlight resistance and having an outer jacket rated for the environment are permitted. Portable power cables are permitted as a permanent wiring method under or within docks and piers or where provided with physical protection. The requirements of NEC 555.13 (B)(4)(b) do not apply.

(c) Overhead wiring must be installed at the perimeter of areas where boats are moored, stored, moved, or serviced to avoid possible contact with masts and other parts of boats.

(d) For the purposes of NEC 555.13 (B)(5), the wiring methods of Chapter 3 NEC will be permitted.

(8) For the purposes of NEC 555.19, receptacles must be mounted not less than twelve inches above the deck surface of the pier or dock (datum plane requirements do not apply for this section). Shore power receptacles that provide shore power for boats must be rated not less than 20 amperes and must be single outlet type and must be of the locking and grounding type or pin and sleeve type.

(9) For the purposes of NEC 555.21, electrical wiring and equipment located at or serving dispensing stations must comply with Article 514 NEC in addition to the requirements of this section.

(a) Boundary classifications.

(i) Class I, Division 1. The area under the dispensing unit is a Class I, Division 1 location. If a dock has one or more voids, pits, vaults, boxes, depressions, or similar spaces where flammable liquid or vapor can accumulate below the dock surface and within twenty feet horizontally of the dispensing unit, then the area below the top of the dock and within twenty feet horizontally of the dispensing unit is a Class I, Division 1 location. See Figure 555-1.

(ii) Class I, Division 2. The area eighteen inches above the water line and within twenty feet horizontally of the dispensing unit is a Class I, Division 2 location. If a dock has one or more voids, pits, vaults, boxes, depressions, or similar spaces where flammable liquid or vapor can accumulate below the dock surface and within twenty feet horizontally of the dispensing unit, then the area to eighteen inches above the top and adjacent to the sides of the dock and within twenty feet horizontally of the dispensing unit is a Class I, Division 2 location. See Figure 555-2.

(b) Portable power cable will be allowed as a permanent wiring method in Class I, Division 2 locations when protected from physical damage.

(10) For the purposes of NEC 555.23, the datum plane requirements do not apply.



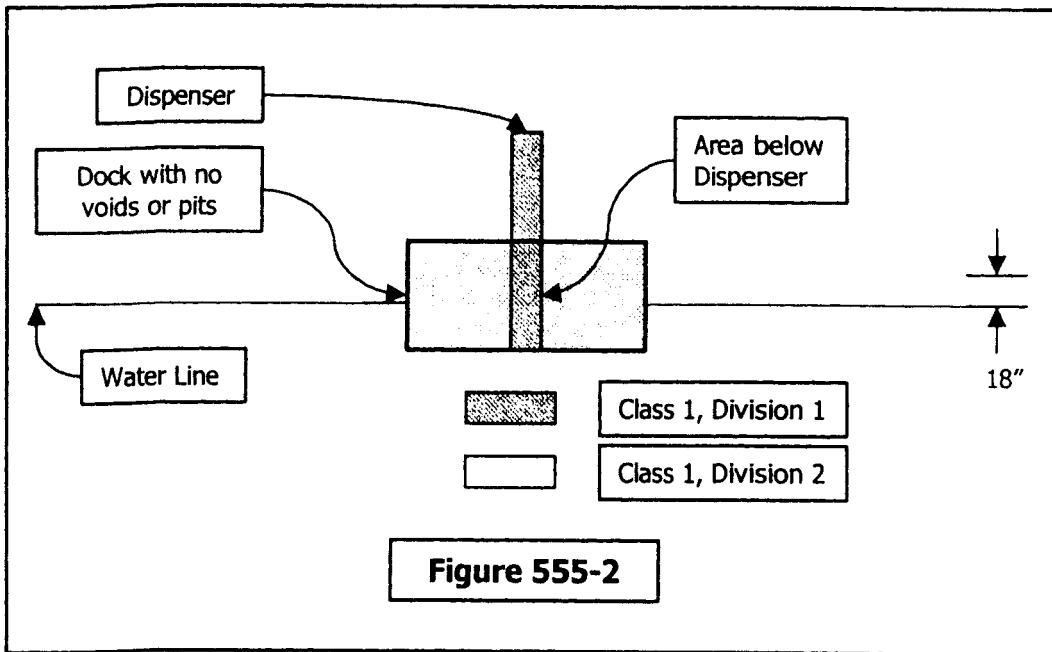
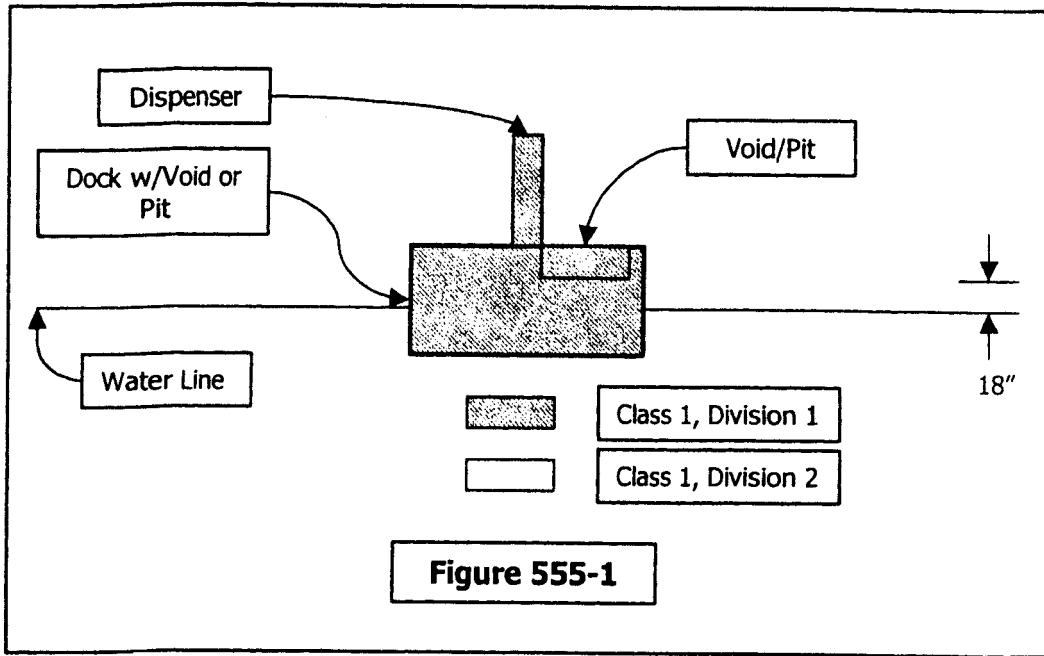

AMENDATORY SECTION (Amending WSR 05-22-025, filed 10/25/05, effective 11/25/05)

**WAC 296-46B-905 Inspection fees.** To calculate inspection fees, the amperage is based on the conductor ampacity or the overcurrent device rating. The total fee must

not be less than the number of progress inspection (one-half hour) units times the progress inspection fee rate from subsection (8) of this section, PROGRESS INSPECTIONS.

The amount of the fee due is calculated based on the fee effective at the date of a department assessed fee (e.g., plan review or fee due) or when the electrical permit is purchased.

(1) Residential.

(a) Single- and two-family residential (New Construction).

Notes:

- (1) Square footage is the area included within the surrounding exterior walls of a building exclusive of any interior courts. (This includes any floor area in an attached garage, basement, or unfinished living space.)
- (2) "Inspected with the service" means that a separate service inspection fee is included on the same electrical work permit.
- (3) "Inspected at the same time" means all wiring is to be ready for inspection during the initial inspection trip.
- (4) An "outbuilding" is a structure that serves a direct accessory function to the residence, such as a pump house or storage building. Outbuilding does not include buildings used for commercial type occupancies or additional dwelling occupancies.

(i) First 1300 sq. ft.	\$73.00
Each additional 500 sq. ft. or portion of	\$23.40
(ii) Each outbuilding or detached garage - inspected at the same time as a dwelling unit on the property	\$30.50
(iii) Each outbuilding or detached garage - inspected separately	\$48.10
(iv) Each swimming pool - inspected with the service	\$48.10
(v) Each swimming pool - inspected separately	\$73.00
(vi) Each hot tub, spa, or sauna - inspected with the service	\$30.50
(vii) Each hot tub, spa, or sauna - inspected separately	\$48.10
(viii) Each septic pumping system - inspected with the service	\$30.50
(ix) Each septic pumping system - inspected separately	\$48.10

(b) Multifamily residential and miscellaneous residential structures, services and feeders (New Construction).

Each service and/or feeder

Ampacity	Service/Feeder	Additional Feeder
0 to 200	\$78.70	\$23.40
201 to 400	\$97.80	\$ 48.10
401 to 600	\$134.30	\$66.90
601 to 800	\$172.30	\$91.80
801 and over	\$245.70	\$184.30

(c) Single or multifamily altered services or feeders including circuits.

(i) Each altered service and/or altered feeder

Ampacity	Service or Feeder
0 to 200	\$66.90
201 to 600	\$97.80
601 and over	\$147.40

(ii) Maintenance or repair of a meter or mast (no alterations to the service or feeder) \$36.30

(d) Single or multifamily residential circuits only (no service inspection).

Note: Altered or added circuit fees are calculated per panelboard. Total cost of the alterations in an individual panel should not exceed the cost of a complete altered service or feeder of the same rating, as shown in subsection (1) RESIDENTIAL (c) (table) of this section.

(i) 1 to 4 circuits (see note above)	\$48.10
(ii) Each additional circuit (see note above)	\$5.30

(e) Mobile homes, modular homes, mobile home parks, and RV parks.

(i) Mobile home or modular home service or feeder only	\$48.10
(ii) Mobile home service and feeder	\$78.70

(f) Mobile home park sites and RV park sites.

Note: For master service installations, see subsection (2) COMMERCIAL/INDUSTRIAL of this section.

(i) First site service or site feeder	\$48.10
(ii) Each additional site service; or additional site feeder inspected at the same time as the first service or feeder	\$30.50

(2) Commercial/industrial.

(a) New service or feeder, and additional new feeders inspected at the same time (includes circuits).

Note: For large COMMERCIAL/INDUSTRIAL projects that include multiple feeders, "inspected at the same time" can be interpreted to include additional inspection trips for a single project. The additional inspections must be for electrical work specified on the permit at the time of purchase. The permit fee for such projects must be calculated from (2)(a)(i)(table) of this section. However, the total fee must not be less than the number of progress inspection (one-half hour) units times the progress inspection fee rate from subsection (8) PROGRESS INSPECTIONS of this section.

Service/feeders

Ampacity	Service/Feeder	Additional Feeder
0 to 100	\$78.70	\$48.10
101 to 200	\$95.80	\$61.30
201 to 400	\$184.30	\$73.00
401 to 600	\$214.80	\$85.80
601 to 800	\$277.70	\$116.90
801 to 1000	\$339.00	\$141.40
1001 and over	\$369.80	\$197.30

(b) Altered services or feeders (no circuits).

(i) Service/feeders

Ampacity	Service or Feeder
0 to 200	\$78.70
201 to 600	\$184.30
601 to 1000	\$277.70
1001 and over	\$308.40

(ii) Maintenance or repair of a meter or mast (no alterations to the service or feeder) \$66.90

(c) Circuits only.

Note: Altered/added circuit fees are calculated per panelboard. Total cost of the alterations in a panel (or panels) should not exceed the cost of a new feeder (or feeders) of the same rating, as shown in subsection (2) COMMERCIAL/INDUSTRIAL (2)(a)(i)(table) above.

(i) First 5 circuits per branch circuit panel	\$61.30
(ii) Each additional circuit per branch circuit panel	\$5.30

(d) Over 600 volts surcharge per permit. \$61.30

(3) Temporary service(s).

Note:

- (1) See WAC 296-46B-527 for information about temporary installations.
- (2) Temporary stage or concert inspections requested outside of normal business hours will be subject to the portal-to-portal hourly fees in subsection (11) OTHER INSPECTIONS. The fee for such after hours inspections shall be the greater of the fee from this subsection or the portal-to-portal fee.

**Temporary services, temporary stage or concert productions.**

Ampacity	Service or Feeder	Additional Feeder
0 to 60	\$42.20	\$21.60
61 to 100	\$48.10	\$23.40
101 to 200	\$61.30	\$30.50
201 to 400	\$73.00	\$36.40
401 to 600	\$97.80	\$48.10
601 and over	\$110.90	\$55.30

Inspections	Fee
1 to 3 plant electricians	\$1,765.50
4 to 6 plant electricians	\$3,532.80
7 to 12 plant electricians	\$5,298.90
13 to 25 plant electricians	\$7,066.20
More than 25 plant electricians	\$8,833.50

**(4) Irrigation machines, pumps, and equipment.**

**Irrigation machines.**

- (a) Each tower - when inspected at the same time as a service and feeder from (2) COMMERCIAL/INDUSTRIAL \$5.30
- (b) Towers - when not inspected at the same time as a service and feeders - 1 to 6 towers \$73.00
- (c) Each additional tower \$5.30

**(5) Miscellaneous - commercial/industrial and residential.**

(a) **A Class 2 low-voltage thermostat** and its associated cable controlling a single piece of utilization equipment or a single furnace and air conditioning combination.

- (i) First thermostat \$36.40
- (ii) Each additional thermostat inspected at the same time as the first \$11.40

(b) **Class 2 or 3 low-voltage systems and telecommunications systems.** Includes all telecommunications installations, fire alarm, nurse call, energy management control systems, industrial and automation control systems, lighting control systems, and similar Class 2 or 3 low-energy circuits and equipment not included in WAC 296-46B-110 for Class B work.

- (i) First 2500 sq. ft. or less \$42.20
- (ii) Each additional 2500 sq. ft. or portion thereof \$11.40

**(c) Signs and outline lighting.**

- (i) First sign (no service included) \$36.40
- (ii) Each additional sign inspected at the same time on the same building or structure \$17.30

**(d) Berth at a marina or dock.**

**Note:** Five berths or more shall be permitted to have the inspection fees based on appropriate service and feeder fees from section (2) COMMERCIAL/INDUSTRIAL (a) (i) above.

- (i) Berth at a marina or dock \$48.10
- (ii) Each additional berth inspected at the same time \$30.50

**(e) Yard pole, pedestal, or other meter loops only.**

- (i) Yard pole, pedestal, or other meter loops only \$48.10
- (ii) Meters installed remote from the service equipment and inspected at the same time as a service, temporary service or other installations \$11.40

**(f) Emergency inspections requested outside of normal working hours.**

Regular fee plus surcharge of: \$91.80

**(g) Generators.**

**Note:** Permanently installed generators: Refer to the appropriate residential or commercial new/altered service or feeder section.

Portable generators: Permanently installed transfer equipment for portable generators \$66.90

**(h) Electrical - annual permit fee.**

**Note:** See WAC 296-46B-900(14).

For commercial/industrial location employing full-time electrical maintenance staff or having a yearly maintenance contract with a licensed electrical contractor. Note, all yearly maintenance contracts must detail the number of contractor electricians necessary to complete the work required under the contract. This number will be used as a basis for calculating the appropriate fee. Each inspection is based on a 2-hour maximum.

**(i) Telecommunications - annual permit fee.**

**Note:**

(1) See WAC 296-46B-900(13).

(2) Annual inspection time required may be estimated by the purchaser at the rate for "OTHER INSPECTIONS" in this section, charged portal-to-portal per hour.

For commercial/industrial location employing full-time telecommunications maintenance staff or having a yearly maintenance contract with a licensed electrical/telecommunications contractor.

2-hour minimum \$146.10

Each additional hour, or portion thereof, of portal-to-portal inspection time \$73.00

**(j) Permit requiring ditch cover inspection only.**

Each 1/2 hour, or portion thereof \$36.40

**(k) Cover inspection for elevator/conveyance installation. This item is only available to a licensed/registered elevator contractor.** \$61.30

**(6) Carnival inspections.**

**(a) First carnival field inspection each calendar year.**

(i) Each ride and generator truck \$17.30

(ii) Each remote distribution equipment, concession, or gaming show \$5.30

(iii) If the calculated fee for first carnival field inspection above is less than \$89.00, the minimum inspection fee shall be: \$91.80

**(b) Subsequent carnival inspections.**

(i) First ten rides, concessions, generators, remote distribution equipment, or gaming show \$91.80

(ii) Each additional ride, concession, generator, remote distribution equipment, or gaming show \$5.30

**(c) Concession(s) or ride(s) not part of a carnival.**

(i) First field inspection each year of a single concession or ride, not part of a carnival \$73.00

(ii) Subsequent inspection of a single concession or ride, not part of a carnival \$48.10

**(7) Trip fees.**

(a) Requests by property owners to inspect existing installations. (This fee includes a maximum of one hour of inspection time. All inspection time exceeding one hour will be charged at the rate for progressive inspections.) \$73.00

(b) Submitter notifies the department that work is ready for inspection when it is not ready. \$36.40

(c) Additional inspection required because submitter has provided the wrong address or incomplete, improper or illegible directions for the site of the inspection. \$36.40

(d) More than one additional inspection required to inspect corrections; or for repeated neglect, carelessness, or improperly installed electrical work. \$36.40

(e) Each trip necessary to remove a noncompliance notice. \$36.40

(f) Corrections that have not been made in the prescribed time, unless an exception has been requested and granted. \$36.40

(g) Installations that are covered or concealed before inspection. \$36.40

**(8) Progress inspections.**

**Note:** The fees calculated in subsections (1) through (6) of this section will apply to all electrical work. This section will be applied to a permit where the permit holder has requested additional inspections beyond the number supported by the permit fee calculated at the rate in subsections (1) through (6) of this section.

**On partial or progress inspections, each 1/2 hour.** \$36.40

**(9) Plan review.**

Fee is thirty-five percent of the electrical work permit fee as determined by WAC 296-46B-905, plus a plan review submission and shipping/handling fee of: \$61.30

(a) Supplemental submissions of plans per hour or fraction of an hour of review time. \$73.00

(b) Plan review shipping and handling fee. \$17.30

**(10) Out-of-state inspections.**

(a) Permit fees will be charged according to the fees listed in this section.

(b) Travel expenses:

All travel expenses and per diem for out-of-state inspections are billed following completion of each inspection(s). These expenses can include, but are not limited to: Inspector's travel time, travel cost and per diem at the state rate. Travel time is hourly based on the rate in subsection (11) of this section.

**(11) Other inspections.**

Inspections not covered by above inspection fees must be charged portal-to-portal per hour: \$73.00

**(12) Refund processing fee.**

All requests for permit fee refunds will be assessed a processing fee. (Refund processing fees will not be charged for electrical contractors, using the contractor deposit system, who request less than twenty-four refunds during a rolling calendar year.) \$11.40

**(13) Variance request processing fee.**

Variance request processing fee. This fee is nonrefundable once the transaction has been validated. \$73.00

**(14) Marking of industrial utilization equipment.**

(a) Standard(s) letter review (per hour of review time). \$73.00

(b) Equipment marking - charged portal-to-portal per hour: \$73.00

(c) All travel expenses and per diem for in/out-of-state review and/or equipment marking are billed following completion of each inspection(s). These expenses can include, but are not limited to: Inspector's travel time, travel cost and per diem at the state rate. Travel time is hourly based on the rate in (b) of this subsection.

**(15) Class B basic electrical work labels.**

(a) Block of twenty Class B basic electrical work labels (not refundable). \$200.00

(b) Reinspection of Class B basic electrical work to assure that corrections have been made (per 1/2 hour timed from leaving the previous inspection until the reinspection is completed). See WAC 296-46B-110(8). \$36.40

(c) Reinspection of Class B basic electrical work because of a failed inspection of another Class B label (per 1/2 hour from previous inspection until the reinspection is completed). See WAC 296-46B-110(8). \$36.40

**(16) Provisional electrical work permit labels.**

(a) Block of twenty provisional electrical work permit labels. \$200.00

AMENDATORY SECTION (Amending WSR 04-12-049, filed 5/28/04, effective 6/30/04)

**WAC 296-46B-911 Electrical testing laboratory and engineer accreditation fees.** The amount of the fee due is calculated based on the fee effective at the date payment is made.

**Electrical testing laboratory**

**Initial filing fee: (Nonrefundable)** \$516.00

**Initial accreditation fee:**

1 product category \$258.00

Each additional category for the next 19 categories \$103.20 each

Maximum for 20 categories or more \$2,218.80

**Renewal fee: (Nonrefundable)** 50% of initial filing fee

**Renewal of existing accreditations**

Each additional category for the next 19 categories \$103.20 each

Maximum for 20 categories or more \$2,218.80

Engineer for evaluating industrial utilization equipment

Initial filing fee: (Nonrefundable) \$516.00

Renewal fee: (Nonrefundable) 50% of initial filing fee

AMENDATORY SECTION (Amending WSR 05-22-025, filed 10/25/05, effective 11/25/05)

**WAC 296-46B-915 Civil penalty schedule.** Each day that a violation occurs will be a separate offense.

Once a violation of chapter 19.28 RCW or chapter 296-46B WAC becomes a final judgment, any additional violation within three years becomes a "second" or "additional" offense subject to an increased penalty as set forth in the following tables.

In case of continued, repeated or gross violation of the provisions of chapter 19.28 RCW or this chapter, or if property damage or bodily injury occurs as a result of the failure of a person, firm, partnership, corporation, or other entity to comply with chapter 19.28 RCW or this chapter the department may double the penalty amounts shown in subsections (1) through (13) of this section.

Continued or repeated violation may occur if the person, firm, partnership, corporation or other entity who violates a provision of chapter 19.28 RCW, chapter 296-46B WAC has received one or more written warnings of a similar violation within a one-year period.

A person, firm, partnership, corporation or other entity who violates a provision of chapter 19.28 RCW or chapter 296-46B WAC is liable for a civil penalty based upon the following schedule.

**(1) Offering to perform, submitting a bid for, advertising, installing or maintaining cables, conductors or equipment:**

(a) That convey or utilize electrical current without having a valid electrical contractor's license.

(b) Used for information generation, processing, or transporting of signals optically or electronically in telecommunications systems without having a valid telecommunications contractor's license.

First offense: \$500

Second offense: \$1,500

Third offense: \$3,000

Each offense thereafter: \$6,000

**(2) Employing an individual for the purposes of chapter 19.28 RCW who does not possess a valid certificate of competency or training certificate to do electrical work.**

First offense: \$250

Each offense thereafter: \$500

**(3) Performing electrical work without having a valid certificate of competency or electrical training certificate.**

First offense: \$250

Each offense thereafter: \$500

**(4) Employing electricians and electrical trainees for the purposes of chapter 19.28 RCW in an improper ratio. Contractors found to have violated this section three times in a three-year period must be the subject of an electrical audit in accordance with WAC 296-46B-975.**

First offense: \$250

Each offense thereafter: \$500

**(5) Failing to provide proper supervision to an electrical trainee as required by chapter 19.28 RCW. Contractors found to have violated this section three times in a three-year period must be the subject of an electrical audit in accordance with WAC 296-46B-975.**

First offense: \$250

Each offense thereafter: \$500

**(6) Working as an electrical trainee without proper supervision as required by chapter 19.28 RCW.**

First offense: \$50 ((see note E))

Second offense: \$250

Each offense thereafter: \$500

**(7) Offering, bidding, advertising, or performing electrical or telecommunications installations, alterations or maintenance outside the scope of the firm's specialty electrical or telecommunications contractors license.**

First offense: \$500

Second offense: \$1,500

Third offense: \$3,000

Each offense thereafter: \$6,000

**(8) Selling or exchanging electrical equipment associated with spas, hot tubs, swimming pools or hydromassage bathtubs which are not listed by an approved laboratory.**

First offense: \$500

Second offense: \$1,000

Each offense thereafter: \$2,000

**Definition:** The sale or exchange of electrical equipment associated with hot tubs, spas, swimming pools or hydromassage bathtubs includes to: "Sell, offer for sale, advertise, display for sale, dispose of by way of gift, loan, rental, lease, premium, barter or exchange."

**(9) Covering or concealing installations prior to inspection.**

First offense: \$250 ((see note E))

Second offense: \$1,000

Each offense thereafter: \$2,000

**(10) Failing to make corrections within fifteen days of notification by the department.**

**Exception:** Where an extension has been requested and granted, this penalty applies to corrections not completed within the extended time period.

First offense: \$250

Second offense: \$1,000

Each offense thereafter: \$2,000

**(11) Failing to obtain or post an electrical/telecommunications work permit or provisional electrical work permit label prior to beginning the electrical/telecommunications installation or alteration.**

**Exception:** In cases of emergency repairs to existing electrical/telecommunications systems, this penalty will not be charged if the permit is obtained and posted no later than the business day following beginning work on the emergency repair.

First offense: \$250

Second offense: \$1,000

Each offense thereafter: \$2,000

**(12) Violating chapter 19.28 RCW duties of the electrical/telecommunications administrator or master electrician.**

(a) Failing to be a member of the firm or a supervisory employee and shall be available during working hours to carry out the duties of an administrator or master electrician.

First offense: \$1,000

Second offense: \$1,500

Each offense thereafter: \$3,000

(b) Failing to ensure that all electrical work complies with the electrical installation laws and rules of the state.

First offense: \$100

Second offense: \$250

Third offense: \$1,000

Each offense thereafter: \$3,000

(c) Failing to ensure that the proper electrical safety procedures are used.

First offense: \$500

Second offense: \$1,500

Each offense thereafter: \$3,000

(d) Failing to ensure that all electrical labels, permits, and certificates required to perform electrical work are used.

First offense: \$250

Each offense thereafter: \$500

(e) Failing to ensure that all electrical licenses, required to perform electrical work are used (i.e., work performed must be in the allowed scope of work for the contractor).

First offense: \$500

Second offense: \$1,500

Third offense: \$3,000

Each offense thereafter: \$6,000

(f) Failing to see that corrective notices issued by an inspecting authority are complied with within fifteen days.

**Exception:** Where an extension has been requested and granted, this penalty applies to corrections not completed within the extended time period.

First offense: \$250

Second offense: \$1,000

Each offense thereafter: \$2,000

(g) Failing to notify the department in writing within ten days if the master electrician or administrator terminates the relationship with the electrical contractor.

First offense: \$500

Second offense: \$1,000

Each offense thereafter: \$3,000

**(13) Violating any of the provisions of chapter 19.28 RCW or chapter 296-46B WAC which are not identified in subsections (1) through (12) of this section.**

RCW 19.28.161 through 19.28.271 and the rules developed pursuant to them.

First offense: \$250

Each offense thereafter: \$500

All other chapter 19.28 RCW provisions and the rules developed pursuant to them.

First offense: \$250

Second offense:	\$750
Each offense thereafter:	\$2,000

- E:** Upon written request to the chief electrical inspector, the penalty amount will be waived for the first citation issued within a three-year period. The written request must be received by the department no later than twenty days after notice of penalty. If a subsequent citation is issued within a three-year period and found to be a final judgment, the penalty amount for the first citation will be reinstated and immediately due and payable. Penalty waivers will not be granted for any citation being appealed under WAC 296-46B-995(11).

**AMENDATORY SECTION** (Amending WSR 05-22-025, filed 10/25/05, effective 11/25/05)

**WAC 296-46B-920 Electrical/telecommunications license/certificate types and scope of work.** (1) **General electrical (01):** A general electrical license and/or certificate encompasses all phases and all types of electrical and telecommunications installations and minor plumbing under RCW 18.106.150. For the purposes of RCW 18.106.150, the like-in-kind replacement includes the appliance or any component part of the appliance (e.g., such as, but not limited to, the thermostat in a water heater).

(2) All specialties listed in this subsection may perform the electrical work described within their specific specialty as allowed by the occupancy and location described within the specialty's scope of work. Except for residential (02), the scope of work for these specialties does not include plumbing work regulated under chapter 18.106 RCW. See RCW 18.106.150 for plumbing exceptions for the residential (02) specialty. For the purposes of RCW 18.106.150, the like-in-kind replacement includes the appliance or any component part of the appliance (e.g., such as, but not limited to, the thermostat in a water heater). **Specialty** (limited) electrical licenses and/or certificates are as follows:

(a) **Residential (02):** Limited to the telecommunications, low voltage, and line voltage wiring of one- and two-family dwellings, or multifamily dwellings not exceeding three stories above grade. All wiring is limited to nonmetallic sheathed cable, except for services and/or feeders, exposed installations where physical protection is required, and for wiring buried below grade.

(i) This specialty also includes the wiring for ancillary structures such as, but not limited to: Appliances, equipment, swimming pools, septic pumping systems, domestic water systems, limited energy systems (e.g., doorbells, intercoms, fire alarm, burglar alarm, energy control, HVAC/refrigeration, etc.), multifamily complex offices/garages, site lighting when supplied from the residence or ancillary structure, and other structures directly associated with the functionality of the residential units.

(ii) This specialty does not include wiring occupancies defined in WAC 296-46B-010(14), or commercial occupancies such as: Motels, hotels, offices, assisted living facilities, or stores.

(iii) See RCW 18.106.150 for plumbing exceptions for the residential (02) specialty.

(b) **Pump and irrigation (03):** Limited to the electrical connection of circuits, feeders, controls, low voltage, related

telecommunications, and services to supply: Domestic and irrigation water pumps, circular irrigating system's pumps and pump houses.

This specialty may also perform the work defined in (c) of this subsection.

(c) **Domestic well (03A):** Limited to the extension of a branch circuit, which is supplied and installed by others, to signaling circuits, motor control circuits, motor control devices, and pumps which do not exceed 7 1/2 horsepower at 250 volts AC single phase input power, regardless of motor controller output or motor voltage/phase, used in residential potable water or residential sewage disposal systems.

(d) **Signs (04):** Limited to placement and connection of signs and outline lighting, the electrical supply, related telecommunications, controls and associated circuit extensions thereto; and the installation of a maximum 60 ampere, 120/240 volt single phase service to supply power to a remote sign only. This specialty may service, maintain, or repair exterior luminaires that are mounted on a pole or other structure with like-in-kind components.

(i) Electrical licensing/certification is not required to:

(A) Clean the nonelectrical parts of an electric sign;

(B) To form or pour a concrete pole base used to support a sign;

(C) To operate machinery used to assist an electrician in mounting an electric sign or sign supporting pole; or

(D) To assemble the structural parts of a billboard.

(ii) Electrical licensing/certification is required to: Install, modify, or maintain a sign, sign supporting pole, sign face, sign ballast, lamp socket, lamp holder, disconnect switch, or any other part of a listed electric sign.

(e) **Limited energy system (06):** Limited to the installation of signaling and power limited circuits and related equipment. This specialty is restricted to low-voltage circuits. This specialty includes the installation of telecommunications, HVAC/refrigeration low-voltage wiring, fire protection signaling systems, intrusion alarms, energy management and control systems, industrial and automation control systems, lighting control systems, commercial and residential amplified sound, public address systems, and such similar low-energy circuits and equipment in all occupancies and locations.

Limited energy electrical contractors may perform all telecommunications work under their specialty (06) electrical license and administrator's certificate.

(f) **HVAC/refrigeration systems:**

(i) See WAC 296-46B-020 for specific HVAC/refrigeration definitions.

(ii) For the purposes of this section when a component is replaced, the replacement must be like-in-kind or made using the equipment manufacturer's authorized replacement component.

(iii) The HVAC/refrigeration specialties described in (f)(v) and (vi) of this subsection may:

(A) Install HVAC/refrigeration: Telecommunications, Class 2 low-voltage control circuit wiring/components in all residential occupancies;

(B) Install, repair, replace, and maintain line voltage components within HVAC/refrigeration equipment. Such line voltage components include product illumination lumi-

naires installed within and powered from the HVAC/refrigeration system (e.g., reach-in beverage coolers, frozen food cases, produce cases, etc.) and new or replaced factory authorized accessories such as internally mounted outlets;

(C) Repair, replace, or maintain the internal components of the HVAC/refrigeration equipment disconnecting means or controller so long as the disconnecting means or controller is not located within a motor control center or panelboard (see Figure 920-1 and Figure 920-2);

(D) Install, repair, replace, and maintain short sections of raceway to provide physical protection for low-voltage cables. For the purposes of this section a short section cannot mechanically interconnect two devices, junction boxes, or other equipment or components; and

(E) Repair, replace, or maintain line voltage flexible supply whips not over six feet in length, provided there are no modifications to the characteristics of the branch circuit/feeder load being supplied by the whip. There is no limitation on the whip raceway method (e.g., metallic replaced by nonmetallic).

(iv) The HVAC/refrigeration specialties described in (f)(v) and (vi) of this subsection may not:

(A) Install line voltage controllers or disconnect switches external to HVAC/refrigeration equipment;

(B) Install, repair, replace, or maintain:

- Integrated building control systems, other than HVAC/refrigeration systems;
- Single stand-alone line voltage equipment or components (e.g., heat cable, wall heaters, radiant panel heaters, baseboard heaters, contactors, motor starters, and similar equipment) unless the equipment or component:

Is exclusively controlled by the HVAC/refrigeration system and requires the additional external connection to a mechanical system(s) (e.g., connection to water piping, gas piping, refrigerant system, ducting for the HVAC/refrigeration system, gas fireplace flume, ventilating systems, etc. (i.e., as in the ducting connection to a bathroom fan)). The external connection of the equipment/component to the mechanical system must be required as an integral component allowing the operation of the HVAC/refrigeration system; or

Contains a HVAC/refrigeration mechanical system(s) (e.g., water piping, gas piping, refrigerant system, etc.) within the equipment (e.g., "through-the-wall" air conditioning units, self-contained refrigeration equipment, etc.);

• Luminaires that serve as a building or structure lighting source, even if mechanically connected to a HVAC/refrigeration system (e.g., troffer luminaire used as a return air device, lighting within a walk-in cooler/freezer used for personnel illumination);

• Raceway/conduit systems;

• Line voltage: Service, feeder, or branch circuit conductors. However, if a structure's feeder/branch circuit supplies HVAC/refrigeration equipment containing a supplementary overcurrent protection device(s), this specialty may install the conductors from the supplementary overcurrent device(s) to the supplemental HVAC/refrigeration equipment if the supplementary overcurrent device and the HVAC/refrigeration equipment being supplied are located within sight of each other (see Figure 920-2); or

• Panelboards, switchboards, or motor control centers external to HVAC/refrigeration system.

(v) HVAC/refrigeration **(06A)**:

(A) This specialty is not limited by voltage, phase, or amperage.

(B) No unsupervised electrical trainee can install, repair, replace, or maintain any part of a HVAC/refrigeration system that contains any circuit rated over 600 volts whether the circuit is energized or deenergized.

(C) This specialty may:

• Install HVAC/refrigeration: Telecommunications, Class 2 low-voltage control circuit wiring/components in other than residential occupancies:

That have no more than three stories on/above grade; or  
Regardless of the number of stories above grade if the installation:

- Does not pass between stories;
- Is made in a previously occupied and wired space; and
- Is restricted to the HVAC/refrigeration system;

• Repair, replace, and maintain HVAC/refrigeration: Telecommunications, Class 2 low-voltage control circuit wiring/components in all occupancies regardless of the number of stories on/above grade.

• Install a bonding conductor for metal gas piping to an existing accessible grounding electrode conductor or grounding electrode only when terminations can be made external to electrical panelboards, switchboards, or other distribution equipment.

(D) This specialty may not install, repair, replace, or maintain: Any electrical wiring governed under article(s) 500, 501, 502, 503, 504, 505, 510, 511, 513, 514, 515, or 516 NEC (i.e., classified locations) located outside the HVAC/refrigeration equipment.

(vi) HVAC/refrigeration - restricted **(06B)**:

(A) This specialty may not perform any electrical work where the primary electrical power connection to the HVAC/refrigeration system exceeds: 250 volts, single phase, or 120 amps.

(B) This specialty may install, repair, replace, or maintain HVAC/refrigeration: Telecommunications, Class 2 low-voltage control circuit wiring/components in other than residential occupancies that have no more than three stories on/above grade.

(C) This specialty may not install, repair, replace, or maintain:

- The allowed telecommunications/low-voltage HVAC/refrigeration wiring in a conduit/raceway system; or
- Any electrical work governed under article(s) 500, 501, 502, 503, 504, 505, 510, 511, 513, 514, 515, or 516 NEC (i.e., classified locations).

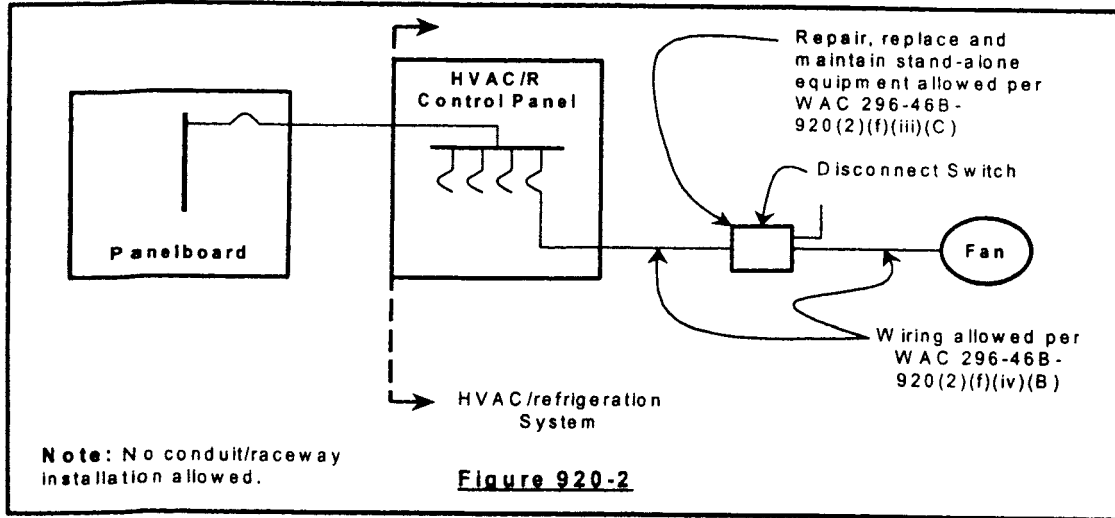
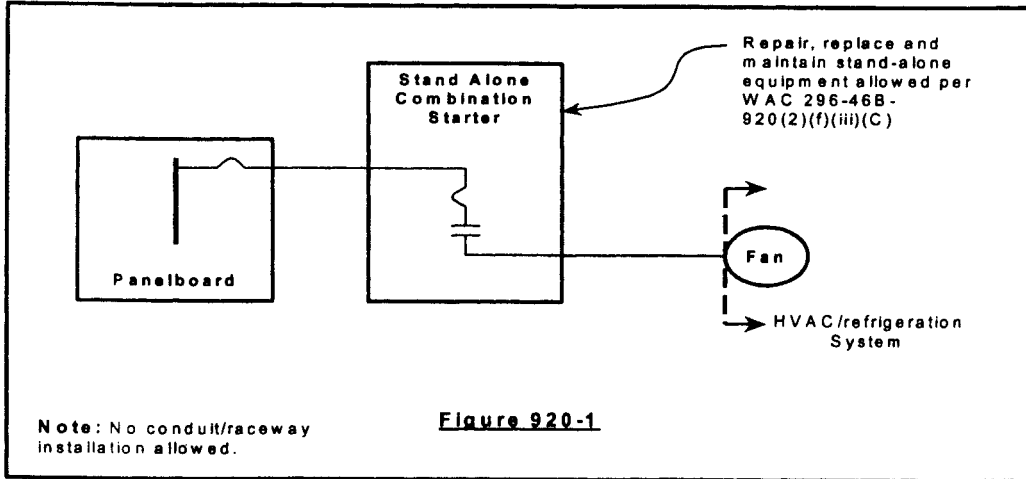

(g) **Nonresidential maintenance (07):** Limited to maintenance, repair and replacement of like-in-kind existing electrical equipment and conductors. This specialty does not include maintenance activities in residential dwellings defined in (a) of this subsection for the purposes of accumulating training experience toward qualification for the residential (02) specialty electrician examination.

This specialty may perform the work defined in (h), (i), (j), (k), and (l) of this subsection.

(h) **Nonresidential lighting maintenance and lighting retrofit (07A):** Limited to working within the housing of existing nonresidential luminaires for work related to repair, service, maintenance of luminaires and installation of energy efficiency lighting retrofit upgrades. This specialty includes replacement of lamps, ballasts, sockets and the installation of listed lighting retrofit reflectors and kits. All work is limited to the luminaire body, except remote located ballasts may be replaced or retrofitted with approved products. This specialty does not include installing new luminaires or branch circuits; moving or relocating existing luminaires; or altering existing branch circuits.

(i) **Residential maintenance (07B):** This specialty is limited to residential dwellings as defined in WAC 296-46B-920 (2)(a), multistory dwelling structures with no commercial facilities, and the interior of dwelling units in multistory structures with commercial facilities. This specialty may maintain, repair, or replace (like-in-kind) existing electrical utilization equipment, and all permit exempted work as defined in WAC 296-46B-900.

This specialty is limited to equipment and circuits to a maximum of 250 volts, 60 amperes, and single phase maximum.

This specialty may disconnect and reconnect low-voltage control and line voltage supply whips not over six feet in length provided there are no modifications to the characteristics of the branch circuit or whip.

For the purpose of this specialty, "electrical equipment" does not include electrical conductors, raceway or conduit systems external to the equipment or whip. This specialty cannot perform any plumbing work regulated under chapter 18.106 RCW.



**(j) Restricted nonresidential maintenance (07C):**

This specialty may maintain, repair, or replace (like-in-kind) existing electrical utilization equipment, and all permit exempted work as defined in WAC 296-46B-900 except for the replacement or repair of circuit breakers.

This specialty is limited to equipment and circuits to a maximum of 277 volts and 20 amperes for lighting branch circuits only and/or maximum 250 volts and 60 amperes for other circuits.

The replacement of luminaires is limited to in-place replacement required by failure of the luminaire to operate. Luminaires installed in suspended lay-in tile ceilings may be relocated providing: The original field installed luminaire supply whip is not extended or relocated to a new supply point; or if a manufactured wiring assembly supplies luminaire power, a luminaire may be relocated no more than eight feet providing the manufactured wiring assembly circuiting is not changed.

This specialty may disconnect and reconnect low-voltage control and line voltage supply whips not over six feet in length provided there are no modifications to the characteristics of the branch circuit. For the purpose of this specialty, "electrical equipment" does not include electrical conductors, raceway or conduit systems external to the equipment or whip.

This specialty may perform the work defined in (h) and (i) of this subsection.

This specialty cannot perform any work governed under Article(s) 500, 501, 502, 503, 504, 505, 510, 511, 513, 514, 515, or 516 NEC (i.e., classified locations). This specialty cannot perform any plumbing work regulated under chapter 18.106 RCW.

**(k) Appliance repair (07D):** Servicing, maintaining, repairing, or replacing household appliances, small commercial/industrial appliances, and other small electrical utilization equipment.

(i) For the purposes of this subsection:

(A) The appliance or electrical utilization equipment must be self-contained and built to standardized sizes or types. The appliance/equipment must be connected as a single unit to a single source of electrical power limited to a maximum of 250 volts, 60 amperes, single phase.

(B) Appliances and electrical utilization equipment include, but are not limited to: Ovens, office equipment, vehicle repair equipment, commercial kitchen equipment, self-contained hot tubs and spas, grinders, and scales.

(C) Appliances and utilization equipment do not include systems and equipment such as: Alarm/energy management/similar systems, luminaires, furnaces/heaters/air conditioners/heat pumps, sewage disposal equipment, door/gate/similar equipment, or individual components installed so as to create a system (e.g., pumps, switches, controllers, etc.).

(ii) This specialty includes:

(A) The in-place like-in-kind replacement of the appliance or equipment if the same unmodified electrical circuit is used to supply the equipment being replaced. This specialty also includes the like-in-kind replacement of electrical components within the appliance or equipment;

(B) The disconnection and reconnection of low-voltage control and line voltage supply whips not over six feet in

length provided there are no modifications to the characteristics of the branch circuit; and

(C) The installation of an outlet box and outlet at an existing appliance or equipment location when converting the appliance from a permanent electrical connection to a plug and cord connection. Other than the installation of the outlet box and outlet, there can be no modification to the existing branch circuit supplying the appliance or equipment.

(iii) This specialty does not include:

(A) The installation, repair, or modification of branch circuits conductors, services, feeders, panelboards, disconnect switches, or raceway/conductor systems interconnecting multiple appliances, equipment, or other electrical components.

(B) Any work governed under Article(s) 500, 501, 502, 503, 504, 505, 510, 511, 513, 514, 515, or 516 NEC (i.e., classified locations).

(C) Any plumbing work regulated under chapter 18.106 RCW.

**(l) Equipment repair (07E):** Servicing, maintaining, repairing, or replacing utilization equipment.

See RCW 19.28.095 for the equipment repair scope of work and definitions. This specialty cannot perform any plumbing work regulated under chapter 18.106 RCW.

**(m) Telecommunications (09):** Limited to the installation, maintenance, and testing of telecommunications systems, equipment, and associated hardware, pathway systems, and cable management systems.

(i) This specialty includes:

(A) Installation of open wiring systems of telecommunications cables.

(B) Surface nonmetallic raceways designated and used exclusively for telecommunications.

(C) Optical fiber innerduct raceway.

(D) Underground raceways designated and used exclusively for telecommunications and installed for additions or extensions to existing telecommunications systems not to exceed fifty feet inside the building.

(E) Incidental short sections of circular or surface metal raceway, not to exceed ten feet, for access or protection of telecommunications cabling and installation of cable trays and ladder racks in telecommunications service entrance rooms, spaces, or closets.

(F) Audio or paging systems where the amplification is integrated into the telephone system equipment.

(G) Audio or paging systems where the amplification is provided by equipment listed as an accessory to the telephone system equipment and requires the telephone system for the audio or paging system to function.

(H) Closed circuit video monitoring systems if there is no integration of line or low-voltage controls for cameras and equipment. Remote controlled cameras and equipment are considered (intrusion) security systems and must be installed by appropriately licensed electrical contractors and certified electricians.

(I) Customer satellite and conventional antenna systems receiving a telecommunications service provider's signal. All receiving equipment is on the customer side of the telecommunications network demarcation point.

(ii) This specialty does not include horizontal cabling used for fire protection signaling systems, intrusion alarms, access control systems, patient monitoring systems, energy management control systems, industrial and automation control systems, HVAC/refrigeration control systems, lighting control systems, and stand-alone amplified sound or public address systems. Telecommunications systems may interface with other building signal systems including security, alarms, and energy management at cross-connection junctions within telecommunications closets or at extended points of demarcation. Telecommunications systems do not include the installation or termination of premises line voltage service, feeder, or branch circuit conductors or equipment. Horizontal cabling for a telecommunications outlet, necessary to interface with any of these systems outside of a telecommunications closet, is the work of the telecommunications contractor.

(n) **Door, gate, and similar systems (10):** This specialty may install, service, maintain, repair, or replace door/gate/similar systems electrical operator wiring and equipment.

(i) For the purposes of this subsection, door/gate/similar systems electrical operator systems include electric gates, doors, windows, awnings, movable partitions, curtains and similar systems. These systems include, but are not limited to: Electric gate/door/similar systems operators, control push buttons, key switches, key pads, pull cords, air and electric treadle, air and electric sensing edges, coil cords, take-up reels, clocks, photo electric cells, loop detectors, motion detectors, remote radio and receivers, antenna, timers, lock-out switches, stand-alone release device with smoke detection, strobe light, annunciator, control panels, wiring and termination of conductors.

(ii) This specialty includes:

(A) Low-voltage, NEC Class 2, door/gate/similar systems electrical operator systems where the door/gate/similar systems electrical operator system is not connected to other systems.

(B) Branch circuits originating in a listed door/gate/similar systems electric operator control panel that supplies only door/gate/similar systems system components providing: The branch circuit does not exceed 600 volts, 20 amperes and the component is within sight of the listed door/gate/similar systems electric operator control panel.

(C) Reconnection of line voltage power to a listed door/gate/similar systems electric operator control panel is permitted provided:

- There are no modifications to the characteristics of the branch circuit/feeder;
- The circuit/feeder does not exceed 600 volts, 20 amperes; and
- The conductor or conduit extending from the branch circuit/feeder disconnecting means or junction box does not exceed six feet in length.

(iii) This specialty does not include any work governed under Article(s) 500, 501, 502, 503, 504, 505, 510, 511, 513, 514, 515, or 516 NEC (i.e., classified locations). This specialty may not install, repair, or replace branch circuit (line voltage) conductors, services, feeders, panelboards, or dis-

connect switches supplying the door/gate/similar systems electric operator control panel.

(3) A specialty electrical contractor, other than the **(06)** limited energy specialty electrical contractor, may only perform telecommunications work within the equipment or occupancy limitations of their specialty electrical contractor's license. Any other telecommunications work requires a telecommunications contractor's license.

Table 920-1 Allowed Scope of Work Crossover

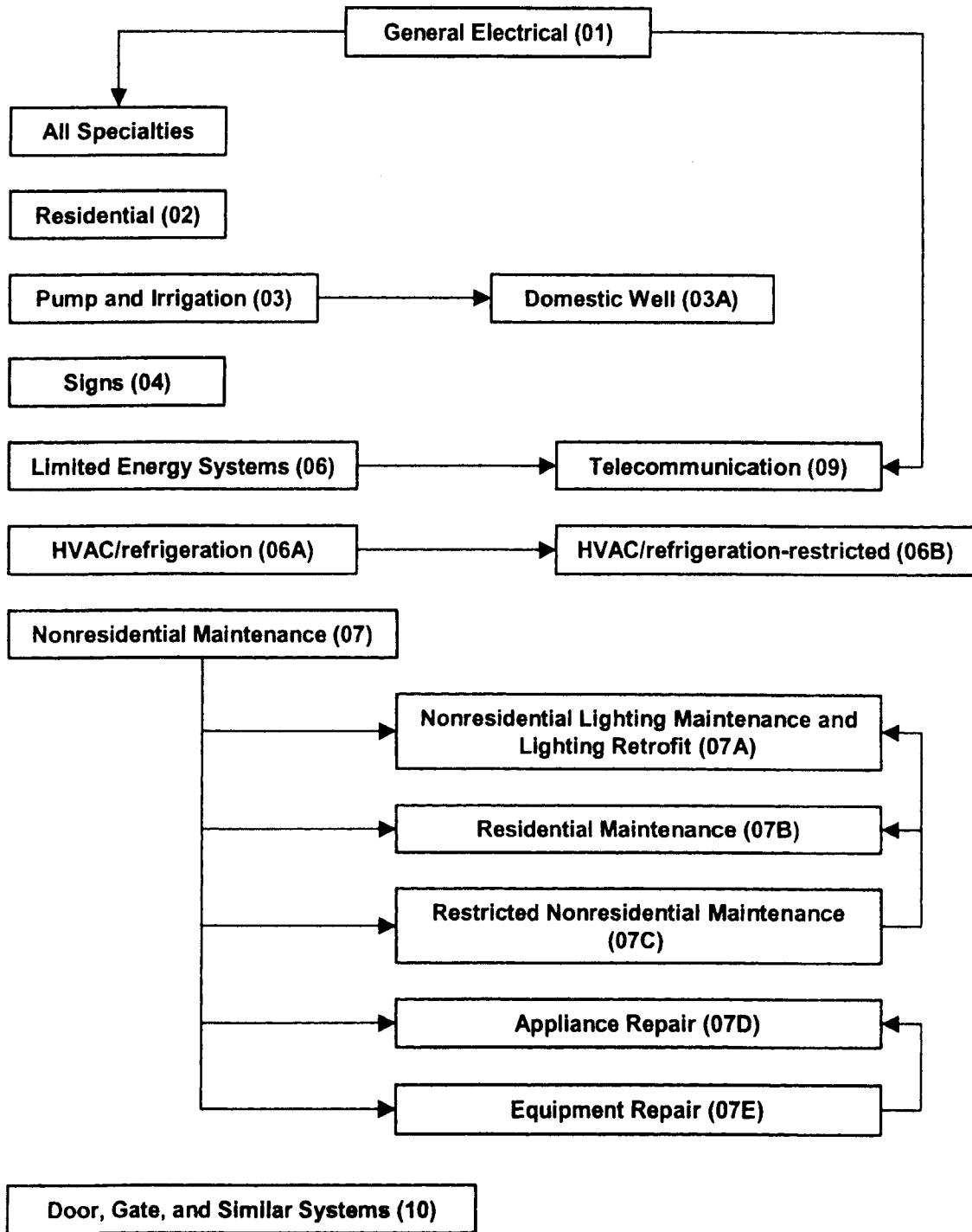

AMENDATORY SECTION (Amending WSR 05-10-024, filed 4/26/05, effective 6/30/05)

**WAC 296-46B-925 Electrical/telecommunications contractor's license. General.**

(1) The department will issue an electrical/telecommunications contractor's license that will expire twenty-four months following the date of issue to a person, firm, partnership, corporation or other entity that complies with require-

ments for such license in chapter 19.28 RCW. An electrical/telecommunications contractor's license will not be issued to or renewed for a person, firm, or partnership unless the Social Security number, date of birth, and legal address of the individual legal owner(s) are submitted with the application. The department may issue an electrical/telecommunications contractor's license for a period greater or less than twenty-four months for the purpose of equalizing the number

of electrical contractor's licenses that expire each month. The department may prorate the electrical/telecommunications contractor's license fee according to the license period.

(2) Combination specialty contractor's license. The department may issue a combination specialty contractor's license to a firm that qualifies for more than one specialty electrical contractor's license. The assigned administrator must be certified in all specialties applicable to the combination specialty contractor's license. The license will plainly indicate the specialty licenses' codes included in the combination license. An administrator assigned to a telecommunications contractor must be certified as a telecommunications administrator. A combination license will not be issued for telecommunications **(09)**.

(3) The department may deny renewal of an electrical/telecommunications contractor's license if a firm, an owner, partner, member, or corporate officer owes money as a result of an outstanding final judgment(s) to the department.

**Electrical/telecommunications contractor cash or securities deposit.**

(4) Cash or securities deposit. The electrical/telecommunications contractor may furnish the department with a cash or security deposit to meet the bond requirements in lieu of posting a bond. A cash or security deposit assigned to the department for bond requirements will be held in place for one year after the contractor's license is expired, revoked, or the owner notifies the department in writing that the company is no longer doing business in the state of Washington as an electrical/telecommunications contractor. Upon written request, the cash or security deposit will then be released by the department providing there is no pending legal action against the contractor under chapter 19.28 RCW of which the department has been notified.

**Telecommunications contractor insurance.**

(5) To obtain a telecommunications contractor's license, the applicant must provide the department with an original certificate of insurance naming the department of labor and industries, electrical section as the certificate holder. Insurance coverage must be no less than twenty thousand dollars for injury or damages to property, fifty thousand dollars for injury or damage including death to any one person, and one hundred thousand dollars for injury or damage including death to more than one person. The insurance will be considered a continuing obligation unless canceled by the insurance company. The insurance company must notify the department in writing ten days prior to the effective date of said cancellation or failure to renew.

(6) The telecommunications contractor may furnish the department with an assigned account to meet the insurance requirements in lieu of a certificate of insurance. An account assigned to the department for insurance requirements will be held in place for three years after the contractor's license is expired, revoked, or the owner notifies the department in writing that the company is no longer doing business in the state of Washington as a telecommunications contractor. Upon written request, the account then will be released by the department providing there is no pending legal action against

the contractor under chapter 19.28 RCW of which the department has been notified.

**Electrical/telecommunications contractor exemptions.**

(7) The following types of systems and circuits are considered exempt from the requirements for licensing and permitting described in chapter 19.28 RCW. The electrical failure of these systems does not inherently or functionally compromise safety to life or property.

Low-voltage thermocouple derived circuits and low-voltage circuits for:

- (a) Built-in residential vacuum systems;
- (b) Underground landscape sprinkler systems;
- (c) Underground landscape lighting; and
- (d) Residential garage doors.

For these types of systems and circuits to be considered exempt, the following conditions must be met:

(e) The power supplying the installation must be derived from a listed Class 2 power supply;

(f) The installation and termination of line voltage equipment and conductors supplying these systems is performed by appropriately licensed and certified electrical contractors and electricians;

(g) The conductors of these systems do not pass through fire-rated walls, fire-rated ceilings or fire-rated floors in other than residential units; and

(h) Conductors or luminaires are not installed in installations covered by the scope of Article 680 NEC (swimming pools, fountains, and similar installations).

(8) Firms who clean and/or replace lamps in luminaires are not included in the requirements for licensing in chapter 19.28 RCW. This exemption does not apply to electric signs as defined in the NEC.

(9) Firms who install listed plug and cord connected equipment are not included in the requirements for licensing in chapter 19.28 RCW. The plug and cord must be a single listed unit consisting of a molded plug and cord and not exceeding 250 volt 60 ampere single phase. The plug and cord can be field installed per the manufacturer's instructions and the product listing requirements. The equipment must be a single manufactured unit that does not require any electrical field assembly except for the installation of the plug and cord.

(10) Firms regulated by the Federal Communications Commission or the utilities and transportation commission, supplying telecommunications service to an end-user's property, are not required to be licensed as a telecommunications contractor under chapter 19.28 RCW for telecommunications installations made ahead of the telecommunications network demarcation point.

(11) Unregulated firms, supplying telecommunications service to an end-user's property, are not required to be licensed as a telecommunications contractor under chapter 19.28 RCW for telecommunications installations made ahead of the telecommunications network demarcation point.

(12) Leaseholders. For electrical installations, maintenance, or alterations to existing buildings only, any person, firm, partnership, corporation, or other entity holding a valid, signed lease from the property owner authorizing the leaseholder to perform electrical work, on the property the leaseholder occupies, will be allowed to purchase an electrical per-

mit(s) and do electrical work on or within the property described in the lease. The lessee and/or his or her regularly employed employees must perform the electrical installation, maintenance and alteration.

The lessee who performs the electrical maintenance or installation work must be the sole occupant of the property or space. Property owners or leaseholders cannot perform electrical work on new buildings for rent, sale, or lease, without the proper electrical licensing and certification. Refer to RCW 19.28.261 for exemptions from licensing and certification.

(13) Assisting a householder. A friend, neighbor, relative, or other person (including a certified electrician) may assist a householder, at his/her residence in the performance of electrical work on the condition that the householder is present when the work is performed and the person assisting the householder does not accept money or other forms of compensation for the volunteer work. For the purposes of this subsection, a residence is a single-family residence.

(14) Volunteering to do electrical work. There are no exceptions from the electrical contractor's license or electrician certification requirements to allow persons to perform volunteer electrical work for anyone other than a householder or a nonprofit organization as allowed by RCW 19.28.091(7). For the purpose of this section, volunteer means that there is no remuneration or receiving of goods or services in return for electrical installations performed.

(15) Farms or place of business. See RCW 19.28.261 for licensing/certification exemptions allowed for the owner(s) of a farm or other place of business and for the employees of the owner.

**Exemptions - electrical utility and electrical utility's contractor.**

(16) Electrical utility system exemption. Neither a serving electrical utility nor a contractor employed by the serving electrical utility is required to have an electrical contractor's license for work on the "utility system" or on service connections or on meters and other apparatus or appliances used to measure the consumption of electricity.

(a) Street lighting exemption. A serving electrical utility is not required to have an electrical contractor's license or electrical permit to work on electrical equipment used in the lighting of streets, alleys, ways, or public areas or squares.

Utilities are allowed to install outside area lighting on privately owned property where the lighting fixture(s) is installed on a utility owned pole(s) used to support utility owned electric distribution wiring or equipment designed to supply electrical power to a customer's property.

Utilities are allowed to install area lighting outside and not attached to a building or other customer owned structure when the areas are outside publicly owned buildings such as: Publicly owned/operated parking lots, parks, schools, play fields, beaches, and similar areas; or the areas are privately owned where the public has general, clear and unrestricted access such as: Church parking lots, and commercial property public parking areas and similar areas.

Utilities are not allowed to install area lighting when the area is privately owned and the public does not have general, clear, and unrestricted access such as industrial property, res-

idential property and controlled commercial property where the public's access is otherwise restricted.

Utilities are not allowed to install area lighting where the lighting is supplied from a source of power derived from a customer owned electrical system.

(b) Customer-owned equipment exemption. A serving electrical utility is not required to have an electrical contractor's license to work on electrical equipment owned by a commercial, industrial, or public institution customer if:

(i) The utility has not solicited such work; and

(ii) Such equipment:

(A) Is located outside a building or structure; and

(B) The work performed is on the primary side of the customer's transformer(s) which supplies power at the customer's utilization voltage.

(c) Exempted equipment and installations. No person, firm, partnership, corporation, or other entity is required to have an electrical contractor's license for work on electrical equipment and installations thereof that are exempted by RCW 19.28.091.

(d) Exemption from inspection.

(i) The work of a serving electrical utility and its contractors on the utility system is not subject to inspection. The utility is responsible for inspection and approval for the installation.

(ii) Work exempted by NEC 90.2 (B)(5), 1981 edition, is not subject to inspection.

**Exemptions - electrical utility telecommunications transition equipment installations, maintenance and repair.**

(17) ~~((Until July 1, 2006,))~~ No license, inspection or other permit will be required by the department of any electric utility or, of any person, firm, partnership or corporation or other entity employed or retained by an electric utility or its contractor, because of work in connection with the installation, maintenance, or repair of telecommunications transition equipment located ahead of the utility's telecommunications network demarcation point on the outside of a building or other structure when the work is performed by a qualified person consistent with the requirements of the National Electric Code (NEC) except as provided in (a) and (b) of this subsection:

(a) The following exceptions to the NEC shall be permitted:

(i) An additional service disconnect supplying power to the transition equipment can be connected on the supply side of the main service disconnect supplying general power to the building;

(ii) Service entrance disconnects may be separated when clearly labeled;

(iii) The service disconnect used for supplying power to the transition equipment must be connected to the grounding electrode system using:

(A) # 8 AWG copper or larger grounding electrode conductor if protected from physical damage; or

(B) # 6 AWG copper or larger grounding electrode conductor if not protected from physical damage;

(iv) Use of equipment or materials that have been listed/field evaluated by a recognized independent testing laboratory or the department;

(v) Low-voltage circuits do not require a separate disconnecting means and may be grounded to the transition equipment grounding system;

(vi) Any other variance to the NEC must be approved by the department.

(b) A variance recommended by a joint utility standards group composed of representatives of both public and private utilities or certified by a professional engineer will be approved by the department unless the recommendation is inconsistent with meeting equivalent objectives for public safety.

(c) For the purposes of this section, a qualified worker is employed by a utility or its contractor and is familiar with the construction or operation of such lines and/or equipment that concerns his/her position and who is proficient with respect to the safety hazards connected therewith, or, one who has passed a journey status examination for the particular branch of the electrical trades with which he/she may be connected or is in a recognized training or apprenticeship course and is supervised by a journey level person.

(d) Although the utility is responsible for inspection and approval of the installation, including the selection of material and equipment, the department reserves the right to audit worker qualifications and inspect such installations semi-annually for conformance with the requirements of (a), (b) and (c) of this subsection but shall not collect a permit fee for such inspection or audit.

(e) If a utility fails to meet the requirements of this section, the department may require the utility to develop and submit a remedial action plan and schedule to attain compliance with this section which may be enforced by the department.

(f) This exemption shall be in addition to any other exemption provided in chapter 19.28 RCW, this chapter or other applicable law.

#### **Exemptions - independent electrical power production equipment exemption.**

(18) An independent electrical power production entity is not required to have an electrical contractor's license to work on electrical equipment used to produce or transmit electrical power if:

(a) The entity is:

(i) The owner or operator of the generating facility is regulated by the Federal Energy Regulatory Commission (FERC);

(ii) A municipal utility, or other form of governmental electric utility, or by an electrical cooperative or mutual corporation; or

(iii) The owner or operator of the generating facility is an independent electrical power producer and the facility generates electrical power only for sale to one or more:

(A) Electrical utilities regulated by FERC, municipal utility, or other form of governmental utility, or to an electric cooperative or mutual corporation; and

(B) The electrical power generated by the facility is not used for self-generation or any other on- or off-site function other than sale to one or more utilities regulated by FERC or by one or more state public utilities commissions, or to a PUD, municipal utility, or other form of governmental elec-

tric utility, or to an electric cooperative or mutual corporation.

(b) The entity must supply the chief electrical inspector a valid master business license issued by the department of licensing, state of Washington so that the entity's status as a revenue generating business can be confirmed.

(c) The entity has entered into an agreement to sell electricity to a utility or to a third party; and

(d) The electrical equipment is used to transmit electricity from the terminals of an electrical generating unit located on premises to the point of interconnection with a utility system.

(e) The electrical power production facility's generation capacity exceeds 115 KVA.

(f) Notwithstanding that a generating facility may be granted an exemption pursuant to this section, the facility will be subject to all the requirements of chapter 19.28 RCW if the facility at any time in the future ceases to comply with the requirements for exemption. All site facilities not exclusively and directly required to generate and/or distribute the electrical power generated on the site are subject to all the licensing and inspection requirements of chapter 19.28 RCW. All facility services, feeders, and circuits not exclusively and directly required to generate and/or distribute the electrical power (e.g., lights, outlets, etc.) must comply with all requirements of chapter 19.28 RCW for licensing and inspection. Facility circuits supplied to equipment required for the function of generation equipment (e.g., block heaters, power supplies, etc.) must comply with all requirements of chapter 19.28 RCW for licensing and inspection up to and including the equipment termination point.

#### **Exemptions - telegraph and telephone utility and telegraph and telephone utility's contractor.**

(19) Telegraph and telephone utility exempted equipment and installations. No person, firm, partnership, corporation, or other entity is required to have an electrical contractor's license for work on electrical equipment and installations thereof that are exempted by RCW 19.28.151. For the purposes of this exemption, "building or buildings used exclusively for that purpose" may mean any separate building or space of a building where the space is separated from the remainder of the building by a two-hour fire wall. The telecommunications or telegraph equipment within such a space must supply telephone or telegraph service to other customer's buildings (i.e., telecommunications or telegraph equipment cannot solely supply the building containing the telephone/telegraph space).

#### **Exemptions - manufacturers of electrical/telecommunications products.**

(20) Manufacturers of electrical/telecommunications systems products will be allowed to utilize a manufacturer's authorized factory-trained technician to perform initial calibration, testing, adjustment, modification incidental to the startup and checkout of the equipment, or replacement of components within the confines of the specific product, without permit or required licensing:

(a) Provided the product:

(i) Has not been previously energized;

(ii) Has been recalled by the Consumer Product Safety Commission;

(iii) Is within the manufacturer's written warranty period; or

(iv) The manufacturer is working under the written request and supervision of an appropriately licensed electrical contractor.

(b) Modifications to the equipment, as designated above, must not include any changes to the original intended configuration nor changes or contact with external or field-connected components or wiring.

(c) The manufacturer will be responsible for obtaining any required reapproval/recertification from the original listing or field evaluation laboratory.

(d) The manufacturer must notify the department if any modifications have been made or reapproval/recertification is required.

(21) Premanufactured electric power generation equipment assemblies and control gear.

(a) Manufacturers of premanufactured electric power generation equipment assemblies and control gear will be allowed to utilize a manufacturer's authorized factory-trained technician to perform initial calibration, testing, adjustment, modification incidental to the startup and checkout of the equipment, or replacement of components within the confines of the specific product, without permit or required licensing, provided:

(i) For transfer equipment, the product has not been previously energized or is within the manufacturer's written warranty period;

(ii) Modifications to the equipment, as designated above, must not include any changes to the original intended configuration nor changes or contact with external or field-connected components or wiring;

(iii) The manufacturer will be responsible for obtaining any required reapproval/recertification from the original listing or field evaluation laboratory; or

(iv) The manufacturer must notify the department if any modifications have been made or reapproval/recertification is required.

(b) Premanufactured electric power generation equipment assemblies are made up of reciprocating internal combustion engines and the associated control gear equipment. Control gear equipment includes control logic, metering, and annunciation for the operation and the quality of power being generated by the reciprocating internal combustion engine and does not have the function of distribution of power.

(c) Modifications of a transfer switch must not include changes to the original intended configuration or changes or contact with externally field-connected components.

(d) For the purposes of this subsection, the following work on premanufactured electric power generation equipment assemblies is not exempt from the requirements of chapter 19.28 RCW:

(i) Installation or connection of conduit or wiring between the power generation unit, transfer switch, control gear;

(ii) Installation of the transfer switch;

(iii) Connections between the power generation unit, transfer switch, control gear, and utility's transmission or distribution systems;

(iv) Connections between the power generation unit, transfer switch, control gear, and any building or structure; or

(v) Test connections with any part of:

(A) The utility's transmission or distribution system; or

(B) The building or structure.

(22) The installation, maintenance, or repair of a medical device deemed in compliance with chapter 19.28 RCW is exempt from licensing requirements under RCW 19.28.091, certification requirements under RCW 19.28.161, and inspection and permitting requirements under RCW 19.28.-101. This exemption does not include work providing electrical feeds into the power distribution unit or installation of conduits and raceways. This exemption covers only those factory engineers or third-party service companies with equivalent training who are qualified to perform such service.

(23) Coincidental electrical/plumbing work. See RCW 19.28.091(8) for the plumber exemption.

(24) Nothing in this section will alter or amend any other exemptions from or requirement for licensure or inspection, chapter 19.28 RCW or this chapter.

AMENDATORY SECTION (Amending WSR 05-10-024, filed 4/26/05, effective 6/30/05)

**WAC 296-46B-945 Qualifying for master, journeyman, specialty electrician examinations.**

**Qualifying for master, journeyman, specialty electrician examinations.**

(1) All applicants must be at least sixteen years of age.

**Qualifying for the master electrician examination.**

(2) An individual may take the master electrician's certificate of competency examination if the individual meets the requirements described in RCW 19.28.191 (1)(d) or (e).

**Qualifying for the master electrician examination from out-of-state.**

(3) No credit may be applied from out-of-state toward qualifying for a master electrician certificate of competency examination.

**Qualifying for the journeyman electrician competency examination.**

(4) An individual may take the journeyman electrician's certificate of competency examination if the individual held a current electrical training certificate and has worked for an employer who employs at least one certified master electrician, journeyman, or specialty electrician on staff and the individual:

(a) Has been employed, in the electrical construction trade, under the direct supervision of a master electrician, journeyman electrician or specialty electrician working in the appropriate specialty in the proper ratio, per RCW 19.28.161, for four years (eight thousand hours). Of the eight thousand hours:

(i) At least two years (four thousand hours) must be in new industrial and/or new commercial electrical installation (excluding all work described for specialty electricians or technicians) under the direct supervision of a master journeyman electrician or journeyman electrician while working for a general electrical contractor; and

(ii) Not more than a total of two years (four thousand hours) may be for work described as an electrical specialty in WAC 296-46B-920(2).

(b) Has completed a four-year apprenticeship program in the electrical construction trade that is registered with the state apprenticeship council while working under the direct supervision of a master journeyman or journeyman electrician in the proper ratio, per RCW 19.28.161; or

(c) Has completed a two-year electrical construction training program as described in RCW 19.28.191 for journeyman electricians, and two years (four thousand hours) of work experience in new industrial and/or new commercial electrical installations (excluding work described for specialty electricians or electrical technicians) under the direct supervision of a journeyman electrician while working for a general electrical contractor in the proper ratio, per RCW 19.28.161. See WAC 296-46B-971 for additional training school information.

Electrical construction training hours gained in specialties requiring less than two years (i.e., four thousand hours) will not be credited towards qualification for journeyman electrician.

The trainee and their employer and/or apprenticeship training director must attest to the accuracy of all information contained on affidavits of experience used to verify eligibility for the examination.

**Qualifying for the journeyman/specialty electrician competency examination when work was performed in a state requiring electrician certification.**

(5) An individual may take the journeyman/specialty electrician's competency examination when the appropriate state having authority certifies to the department that:

(a) The work was legally performed under the other state's licensing and certification requirements;

(i) For journeyman applicants who meet the minimum hour requirements described in WAC 296-46B-945(4).

(ii) For specialty applicants who meet the minimum hour requirements described in WAC 296-46B-945(9).

(b) The other state's certificate of competency was obtained by examination.

Electrical construction training hours gained in specialties requiring less than two years (i.e., four thousand hours) may not be credited towards qualification for journeyman electrician.

**Qualifying for the journeyman/specialty electrician competency examination when work was performed in a state that does not require electrician certification.**

(6) If the other state requires electrical contractor licensing:

(a) An individual may take the journeyman/specialty electrician's competency examination when an appropriately licensed electrical contractor(s) files a notarized letter of

experience with the department accompanied by payroll documentation which certifies and shows that:

(i) For journeyman applicants: The individual meets the minimum hour requirements described in WAC 296-46B-945(4).

(ii) For specialty applicants: The individual meets the minimum hour requirements described in WAC 296-46B-945(9).

(b) An individual may take the journeyman/specialty electrician's competency examination when an employer(s), acting under a property owner exemption, files a notarized letter of experience from the property owner with the department accompanied by payroll documentation which certifies and shows that:

(i) For journeyman applicants: The individual meets the minimum hour requirements described in WAC 296-46B-945(4).

(ii) For specialty applicants: The individual meets the minimum hour requirements described in WAC 296-46B-945(9).

(7) If the other state does not require electrical contractor licensing or registration: An individual may take the journeyman/specialty electrician's competency examination when the individual's employer(s) files a notarized letter(s) of experience with the department accompanied by payroll documentation which certifies and shows that:

(a) For journeyman applicants: The individual meets the minimum work requirements described in WAC 296-46B-945(4).

(b) For specialty applicants: The individual meets the minimum work requirements described in WAC 296-46B-945(9).

(8) The letter of experience described in subsections (6) and (7) of this section should include a complete list of the individual's usual duties with percentages attributed to each.

**Qualifying for a specialty electrician certificate of competency or examination.**

(9) An individual may qualify for a specialty electrician's examination and certificate of competency if the individual held a current electrical training certificate, and has worked for an employer who employs at least one certified master journeyman electrician, journeyman electrician, appropriate master specialty electrician, or appropriate specialty electrician on staff and the individual:

(a) Has been employed, in the electrical construction trade, under the direct supervision of an appropriate electrician in the appropriate specialty as follows:

**Table 945-1 Experience Hours**

Specialty	Minimum Hours of Work Experience Required to be Eligible for Examination <sup>(4)(5)</sup>	Minimum Hours of Work Experience Required for Certification
Residential certificate (02)	4,000 <sup>(3)</sup>	4,000
Pump and irrigation certificate (03)	4,000 <sup>(3)</sup>	4,000



Table 945-1 Experience Hours

Specialty	Minimum Hours of Work Experience Required to be Eligible for Examination <sup>(4)(5)</sup>	Minimum Hours of Work Experience Required for Certification
Domestic well certificate (03A)	720 <sup>(1)(2)</sup>	2,000 <sup>(6)</sup>
Signs certificate (04)	4,000 <sup>(3)</sup>	4,000
Limited energy system certificate (06)	4,000 <sup>(3)</sup>	4,000
HVAC/refrigeration system certificate (06A)	4,000 <sup>(3)</sup>	4,000 <sup>(7)</sup>
HVAC/refrigeration-restricted (06B)	1,000 <sup>(1)(2)</sup>	2,000 <sup>(6)</sup>
Nonresidential maintenance certificate (07)	4,000 <sup>(3)</sup>	4,000
Nonresidential lighting maintenance and lighting retrofit certificate (07A)	720 <sup>(1)(2)</sup>	2,000 <sup>(6)</sup>
Residential maintenance certificate (07B)	720 <sup>(1)(2)</sup>	2,000 <sup>(6)</sup>
Restricted nonresidential maintenance certificate (07C)	1,000 <sup>(3)</sup>	2,000 <sup>(6)</sup>
Appliance repair certificate (07D)	720 <sup>(1)(2)</sup>	2,000 <sup>(6)</sup>
Equipment repair certificate (07E)	1,000 <sup>(1)(2)</sup>	2,000 <sup>(6)</sup>
Door, gate, and similar systems certificate (10)	720 <sup>(1)(2)</sup>	2,000 <sup>(6)</sup>

- Notes:**
- <sup>(1)</sup>Until the examination is successfully completed, the trainee must work under one hundred percent supervision. Once the appropriate examination is successfully completed, the modified supervision trainee may work under zero percent supervision.
  - <sup>(2)</sup>Two calendar years after the date of initial trainee certification, the trainee must work under seventy-five percent supervision until all required work experience hours are gained and credited towards the minimum work experience requirement even if the trainee has completed the examination.
  - <sup>(3)</sup>This specialty is not eligible for modified trainee status as allowed in chapter 19.28 RCW.
  - <sup>(4)</sup>The trainee and their employer and/or apprenticeship training director must attest to the accuracy of all information contained on affidavits of experience used to verify eligibility for the examination.
  - <sup>(5)</sup>Neither previous work experience credit nor training school credit is allowed as a substitute for the initial hours of minimum work experience required to be eligible for examination unless the trainee's work experience hours under direct supervision are provided as required in RCW 19.28.191 (1) (g)(ii).
  - <sup>(6)</sup>Electrical construction training hours gained in specialties requiring less than two years for certification may not be credited towards qualification for journeyman electrician.
  - <sup>(7)</sup>The 2,000 minimum hours of work experience required for certification as a HVAC/refrigeration-restricted (06B)

specialty electrician may be credited as 2,000 hours towards the 4,000 minimum hours of work experience required for certification as a HVAC/refrigeration (06A) specialty electrician. Hours of work experience credited from the HVAC/refrigeration-restricted (06B) specialty cannot be credited towards qualification for taking the general electrician (01) examination or minimum work experience requirements.

(b) Or has completed an appropriate two-year apprenticeship program in the electrical construction trade that is registered with the state apprenticeship council while working under the direct supervision of an electrician in the appropriate specialty in the proper ratio, per RCW 19.28.161.

**Qualifying for a certificate of competency when the Washington electrical work experience is exempt from certification requirements in RCW 19.28.261.**

(10) To receive credit for electrical work experience that is exempted in RCW 19.28.261, an individual must provide the department with verification from the employer or owner according to WAC 296-46B-965 (i.e., affidavit(s) of experience). For the purposes of this section, exempt work does not include work performed on property owned by the individual seeking credit.

(11) All exempt individuals learning the electrical trade must obtain an electrical training certificate from the department and renew it biannually in order to receive credit for hours worked in the trade according to WAC 296-46B-965.

(12) The department may require verification of supervision in the proper ratio from the certified supervising electrician(s).

(13) Telecommunications work experience:

(a) Credit may be verified only by employers exempted by RCW 19.28.261, general electrical (01) contractors, and limited energy system (06) electrical contractors for limited energy experience for telecommunications work done:

(i) Under the supervision of a certified journeyman or limited energy electrician; and

(ii) In compliance with RCW 19.28.191.

(b) Individuals who want to obtain credit for hours of experience toward electrician certification for work experience doing telecommunications installations must:

(i) Obtain an electrical training certificate;

(ii) Renew the training certificate biannually in order to receive credit for hours worked in the trade according to WAC 296-46B-965.

(c) Telecommunications contractors may not verify telecommunications work experience toward electrician certification.

**AMENDATORY SECTION** (Amending WSR 05-10-024, filed 4/26/05, effective 6/30/05)

**WAC 296-46B-960 Administrator and electrician certificate of competency examinations. General.**

(1) The minimum passing score on any examination or examination section is seventy percent. If examination is requested to be administered by the department, an application is required and the examination must be successfully completed within one year of application or the individual

must submit a new application for exam including all appropriate fees.

(2) All examinations are open book.

(a) Candidates may use:

(i) Any original copyrighted material;

(ii) A silent, nonprinting, nonprogrammable calculator that is not designed for preprogrammed electrical calculations;

(iii) Copies of chapter 19.28 RCW and this chapter; or

(iv) A foreign language dictionary that does not contain definitions.

(b) Candidates may not use:

(i) Copies of copyrighted material;

(ii) Copies of internet publications, except for RCWs or WACs;

(iii) Personal notes; or

(iv) A personal computing device of any type other than the calculator in (a)(ii) of this subsection.

(3) Administrator (~~and~~), master electrician, and electrician examinations may consist of multiple sections. All sections must be successfully completed within a one-year examination period (~~of~~) after beginning the examination. Within the one-year examination period, the candidate does not have to retake any sections successfully completed within the examination period. If all sections are not successfully completed within the one-year period, the candidate must begin a new examination period and retake all sections.

#### Special accommodations for examination.

(4) An applicant for an examination who, due to a specific physical, mental, or sensory impairment, requires special accommodation in examination procedures, may submit a written request to the chief electrical inspector for the specific accommodation needed.

(a) The applicant must also submit to the department a signed and notarized release, authorizing the specifically identified physician or other specialist to discuss the matter with the department representative. The applicant must also submit an individualized written opinion from a physician or other appropriate specialist:

(i) Verifying the existence of a specific physical, mental, or sensory impairment;

(ii) Stating whether special accommodation is needed for a specific examination;

(iii) Stating what special accommodation is necessary; and

(iv) Stating if extra time for an examination is necessary and if so, how much time is required. The maximum allowance for extra time is double the normal time allowed.

(b) The written request for special accommodation and individualized written opinion must be submitted to the department at least six weeks in advance of the examination date and must be accompanied by a completed application and fees as described in WAC 296-46B-910.

(c) Only readers and interpreters provided from the administrative office of the courts and/or approved by the department may be used for reading or interpreting the examination. The applicant will be required to bear all costs associated with providing any reading or interpretive services used for an examination.

(d) Applicants who pass the examination with the assistance of a reader or interpreter will be issued a certificate with the following printed restriction: "Requires reading supervision for product usage." A competent reader or interpreter must be present on any job site where a person with this restriction is performing electrical work as described in chapter 19.28 RCW.

Applicants who pass the examination with the assistance of a mechanical device (e.g., magnifier, etc.) will be issued a certificate with the following printed restriction: "Requires mechanical reading assistance for product usage." Appropriate mechanical reading assistance must be present on any job site where a person with this restriction is performing electrical work as described in chapter 19.28 RCW.

If a candidate successfully retakes the examination without the assistance of a reader or translator, a new certificate will be issued without the restriction.

(5) Applicants who wish to use a foreign language dictionary during an examination must obtain approval at the examination site prior to the examination. Only dictionaries without definitions will be approved for use.

#### Failed examination appeal procedures.

(6) Any candidate who takes an examination and does not pass the examination may request a review of the examination.

(a) The department will not modify examination results unless the candidate presents clear and convincing evidence of error in the grading of the examination.

(b) The department will not consider any challenge to examination grading unless the total of the potentially revised score would result in a passing score.

(7) The procedure for requesting an informal review of examination results is as follows:

(a) The request must be made in writing to the chief electrical inspector and must be received within twenty days of the date of the examination and must request a rescore of the examination. The written request must include the appropriate fees for examination review described in WAC 296-46B-910.

(b) The following procedures apply to a review of the results of the examination:

(i) The candidate will be allowed one hour to review their examination.

(ii) The candidate must identify the challenged questions of the examination and must state the specific reason(s) why the results should be modified with multiple published reference material supporting the candidate's position.

(iii) Within fifteen days of the candidate's review, the department will review the examination and candidate's justification and notify the candidate in writing of the department's decision.

#### Subjects included in administrator certificate, or master electrician, journeyman, or specialty electrician competency examinations.

(8) The following subjects are among those that may be included in the examination for an administrator certificate or electrician certificate of competency. The list is not exclu-

sive. The examination may also contain subjects not on the list.

(a) For general administrators, master journeyman, and journeyman electricians:

AC - Generator; 3-phase; meters; characteristics of; power in AC circuits (power factor); mathematics of AC circuits.

Administration - Chapter 19.28 RCW and this chapter.

Air conditioning - Basic.

Blueprints - Surveys and plot plans; floor plans; service and feeders; electrical symbols; elevation views; plan views.

Building wire.

Cable trays.

Calculations.

Capacitive reactance.

Capacitor - Types; in series and parallel.

Circuits - Series; parallel; combination; basic; branch; outside branch circuits; calculations.

Conductor - Voltage drop (line loss); grounded.

Conduit - Wiring methods.

DC - Generator; motors; construction of motors; meters.

Definitions - Electrical.

Electrical units.

Electron theory.

Fastening devices.

Fire alarms - Introduction to; initiating circuits.

Fuses.

Generation - Electrical principles of.

Grounding.

Incandescent lights.

Inductance - Introduction to; reactance.

Insulation - Of wire.

Mathematics - Square root; vectors; figuring percentages.

Motors/controls - Motors vs. generators/CEMF; single phase; capacitor; repulsion; shaded pole; basic principles of AC motors.

Ohm's Law.

Power.

Power factor - AC circuits; correction of; problems.

Rectifiers.

Resistance - Of wire.

Rigging.

Safety - Electrical shock.

Services.

3-wire system.

Tools.

Transformers - Principles of; types; single-phase; 3-phase connections.

Voltage polarity across a load.

Wiring methods - Conduit; general.

Wiring systems - Less than 600 volts; 480/277 volts; single-and 3-phase delta or wye; distribution systems over 600 volts.

**Note:** The general administrator, master journeyman, and journeyman electrician examinations may also include the subjects listed below for specialty electrician examinations.

(b) For specialty administrators, master specialty and specialty electricians, the following subjects are among those that may be included in the examination. Examination sub-

jects are restricted to those subjects related to the scope of work of the specialty described in WAC 296-46B-920. The list is not exclusive. The examination may also contain subjects not on the list.

AC - Meters.

Administration - Chapter 19.28 RCW and this chapter.

Appliance circuits or controls.

Blueprints - Floor plans; service and feeders.

Cables - Wiring methods.

Calculations.

Circuits - Series; parallel; combination; basic; outside branch.

Conductor - Voltage drop (line loss); grounded; aluminum or copper.

Conduit - Wiring methods.

Electrical signs, circuits, controls, or services.

Electrical units.

First aid.

Fuses.

General lighting.

Grounding of conductors.

Insulation of wire.

Limited energy circuits or systems.

Maintenance of electrical systems.

Mathematics - Figuring percentage.

Motor circuits, controls, feeders, or services.

Ohm's Law.

Overcurrent protection.

Resistance of wire.

Safety - Electrical shock.

Services.

Sizes of building wire.

3-wire system.

Tools.

Transformer - Ratios; single-phase/3-phase connections.

#### **Failing an administrator certificate exam or electrician certificate of competency examination.**

(9) Anyone failing an administrator or electrician competency examination may retake the examination by making arrangements with the testing agency and paying the retesting fee.

(10) If the individual makes a score of less than sixty percent, the individual must wait two weeks before being eligible to retake.

(11) If the individual makes a score of sixty to sixty-nine percent, the individual must wait one day before being eligible to retake.

(12) If the individual fails an electrician examination or a part of an administrator or master electrician examination three times within a one-year period, the individual must wait three months to retake the failed portion of the examination.

(13) Anyone failing an electrician competency examination may continue to work in the electrical trade if they have a valid electrical training certificate and work under the direct supervision of a certified journeyman or specialty electrician in the proper ratio, per RCW 19.28.161. However, if the applicant holds a temporary specialty electrician certificate per WAC 296-46B-940(28), the applicant may continue to work under the temporary specialty electrician certificate

until it expires. After the temporary specialty electrician certificate expires, the applicant must obtain a valid electrical training certificate and work under the direct supervision of a certified journeyman or specialty electrician in the proper ratio, per RCW 19.28.161.

#### **Cheating on an examination.**

(14) Anyone found cheating on an examination or using inappropriate materials/equipment during an examination will be required to wait at least eleven months before being allowed to reexamine. All such reexaminations will be administered by the department in Tumwater, Washington and the candidate will be required to apply and schedule for the examination with the chief electrical inspector.

AMENDATORY SECTION (Amending WSR 04-12-049, filed 5/28/04, effective 6/30/04)

#### **WAC 296-46B-995 Electrical board—Appeal rights and hearings. General.**

(1) Chapter 19.28 RCW provides the authority for the duties and responsibilities of the electrical board. Except as provided in chapter 19.28 RCW and this chapter, all proceedings will be conducted according to chapter 34.05 RCW the Administrative Procedure Act and chapter 10-08 WAC, Model rules of procedure. See chapter 34.05 RCW the Administrative Procedure Act for specific definitions not described in this chapter.

(2) See RCW 19.28.311 for the composition of the electrical board.

(3) The board adopts the current edition of the "*Roberts' Rules of Order, Newly Revised.*"

(4) The board will hold regular meetings on the last Thursday of January, April, July, and October of each year per RCW 19.28.311.

(5) The director or the chairperson of the board may call a special meeting at any time.

(6) Each board member must be notified in writing of the agenda, date, time, and place of each regular and special meeting. "Writing" includes by electronic mail, also known as "e-mail," if the member has provided an e-mail address for such notice.

(7) The board or department may elect to have an appeal heard by the office of administrative hearings either tape recorded or transcribed by a court reporter; and the board may so elect regarding hearings or board reviews heard by the board as a whole.

(8) A majority of the board constitutes a quorum for purposes of rendering any decision.

(a) If a majority does not attend a hearing or board review on an appeal, the board may either continue the hearing or board review to a date certain or may hear the testimony and arguments.

(b) If the board hears the testimony and arguments, the members of the board who are absent may make their decisions after hearing the tape recording or reading the transcript, of the hearing or board review.

(c) If the board selects the method in subsection (8)(b) of this section, at the time of the hearing, the board shall set a date certain for the absent members to complete review of the

record and for the board as a whole to vote on the decision. The vote in subsection (8)(b) and (c) of this section may occur by U.S. mail, facsimile or by electronic mail and shall be determined by the board at the hearing; the members' votes shall be public record.

(9) All filings and documents for any matter before the board must be submitted to the chief electrical inspector, as secretary to the board, 7273 Linderson Way, P.O. Box 44460, Olympia, WA 98504-4460. The filings may be submitted by ordinary mail, certified or registered mail, or by personal delivery.

(10) All hearings before the board as a whole shall be held on regularly scheduled meeting dates, as listed in subsection (4) of this section, unless the board determines that an alternate date is necessary. All notices of appeal, with a certified check payable to the department in the sum of two hundred dollars if required, must be received in the office of the chief electrical inspector, as secretary to the board, at least thirty days before the regularly scheduled board meeting at which the hearing would occur. The appellant must submit any written argument, briefs testimony or documents for the board's consideration at least twenty days prior to the scheduled hearing.

#### **Appeals**

(11) Appeals of penalties issued by the department.

(a) A party may appeal a penalty issued by the department, pursuant to chapter 19.28 RCW and this chapter, to the board. The appeal shall be assigned to the office of administrative hearings.

(b) The appeal must be filed within twenty days after the notice of the decision or penalty is ~~((served on))~~ given to the assessed party either by personal service or by certified mail, return receipt requested, sent to the last known address of the assessed party and shall be made by filing a written notice of appeal with the chief electrical inspector, as secretary to the board. The request for an appeal must be accompanied with a certified check payable to the department in the sum of two hundred dollars.

(12) Appeals of proposed decisions issued by the office of administrative hearings.

(a) A party may appeal a proposed decision issued by the office of administrative hearings pursuant to chapter 19.28 RCW to the board. The appeal must be filed within twenty days after service of the decision and must be made by filing a written notice of appeal with the chief electrical inspector, as secretary to the board.

(b) The notice of appeal of a proposed decision must be received in the office of the chief electrical inspector, as secretary to the board, at least thirty days before a regularly scheduled board meeting. The appellant must submit any written argument, briefs testimony or documents for the board's consideration at least twenty days prior to the scheduled hearing.

(13) Appeals of suspension or revocation.

(a) An appeal of the suspension or revocation of a license or certificate of competency under RCW 19.28.241 and 19.28.341 will be heard by the board in accordance with chapter 34.05 RCW and not assigned to the office of administrative hearings. The board will conduct the hearing and

may elect to have the assistance of an administrative law judge in the proceeding.

(b) The notice of appeal, with the certified check payable to the department in the sum of two hundred dollars for appeals of a revocation or suspension of a contractor's or administrator's license, must be filed within twenty days after the notice of suspension or revocation is served on the subject of said action, either by personal service or by certified mail, return receipt requested, sent to the last known address of the subject and shall be filed by written notice of appeal with the chief electrical inspector, as secretary to the board.

(14) Appeals of decisions on installation.

(a) A party may seek board review for disputes relating to the interpretation and application of electrical/telecommunications installation or maintenance standards under RCW 19.28.111, 19.28.480, and 19.28.531. The board will conduct the hearing and may elect to have the assistance of an administrative law judge in the proceeding.

(b) The notice of appeal, with the certified check payable to the department in the sum of two hundred dollars, must be received in the office of the chief electrical inspector, as secretary to the board, at least thirty days before a regularly scheduled board meeting. The appellant must submit any written argument, briefs testimony or documents for the board's consideration at least twenty days prior to the scheduled hearing.

(15) Appeals of a continuing education class or instructor for denials or revocations.

A party may appeal a decision issued by the department, pursuant to WAC 296-46B-970 (3)(e)(vi), if the department acts as the contractor pursuant to WAC 296-46B-970 (2)(h) to the superior court per RCW 34.05.542(3).

(16) Judicial review of final decisions of the board.

A party may seek judicial review of a final order of the board within thirty days after service of the decision. Appeals of final decisions and orders must be done in accordance with chapter 34.05 RCW.

(17) If appeal(s) according to subsections (11), (12), (13), and (15) of this section are not filed or the appeal is not filed timely, the proposed decision or action becomes final with no further action on the part of the department or the board.

(18) Appeals - general requirements.

(a) Appeals according to subsections (11), (12), or (15) of this section must specify the contentions of the appellant, and must for subsection (12) of this section specify to which conclusions of law and findings of fact the party takes exception. The appeal will be based on the record of the hearing. The board shall not grant a hearing de novo.

(b) In appeals under subsections (12), (13), (14), and (15) of this section, the issues to be adjudicated must be made as precise as possible, in order that the board may proceed promptly to conduct the hearing on relevant and material matter only.

(c) In all appeals of chapter 19.28 RCW and this chapter, the appellant has the burden of proof by a preponderance of the evidence.

### Appearance and practice before board.

(19) No party may appear as a representative in proceedings other than the following:

(a) Attorneys at law qualified to practice before the supreme court of the state of Washington;

(b) Attorneys at law qualified to practice before the highest court of record of another state, if the attorneys at law of the state of Washington are permitted to appear as representatives before administrative agencies of the other state, and if not otherwise prohibited by Washington law; or

(c) An owner, officer, partner, or full-time employee of a firm, association, organization, partnership, corporation, or other entity who appears for the firm, association, organization, partnership, corporation or other entity.

(20) All persons appearing in proceedings as a representative must conform to the standards of ethical conduct required of attorneys before the courts of Washington. If a person does not conform to these standards, the board may decline to permit the person to appear as a representative in any proceeding before the board.

### NEW SECTION

**WAC 296-46B-997 Engineer approval.** (1) This section describes the methods required to obtain recognition and accreditation of professional engineers registered under chapter 18.43 RCW to approve industrial utilization equipment. This section provides assurance to the general consuming public that electrical products have been tested for safety and identified for their intended use.

(2) Industrial utilization equipment is considered to be safe when it is certified by an engineer accredited by the department.

(a) The department may declare industrial utilization equipment unsafe if:

(i) The equipment is not being manufactured or produced in accordance with all standards of design and construction and all terms and conditions set out in the certification report for the equipment referred to in this chapter;

(ii) The equipment has been shown by field experience to be unduly hazardous to persons or property;

(iii) An examination of the equipment or of the certification report for the equipment shows that the equipment does not comply with all applicable standards; or

(iv) An examination of the certification report or the equipment shows that the equipment cannot be installed in accordance with this chapter.

(b) When the department declares industrial utilization equipment unsafe, the department will notify the product owner and the certifying engineer in writing.

### Accreditation - general.

(3) The department's chief electrical inspector's office reviews requests for accreditation. Applicants must submit supporting data to document and verify the requirements of this section have been met.

(4) The accreditation of an engineer will be valid for the period of three years.

(5) On-site inspection of an engineer's facilities.

(a) On-site inspection of the facility(ies) may be required during the initial application process or the renewal process. Representative(s) of the department will evaluate for compliance with accreditation criteria.

(b) The applicant must pay all costs associated with the on-site inspection.

(6) For purposes of chapter 19.28 RCW, all engineers who certify industrial utilization equipment offered for sale in the state of Washington must be accredited by the department.

(7) Fees are payable as required in WAC 296-46B-911.

(8) The engineer must apply for renewal of accreditation at least thirty days prior to the accreditation expiration date. The department will renew accreditation for the period of three years or notify the renewing laboratory of the department's reason(s) of refusal following receipt of the completed form and renewal fee.

(9) The department accepts or denies engineer accreditation for engineers seeking to evaluate industrial utilization equipment within the state. Accreditation is determined when an engineer provides evidence to the department that all the requirements of this chapter are met. Accreditation is determined by the department and prior to making a determination, the department may require information and documentation to be provided by the engineer.

(a) Accreditation is subject to review when deemed necessary by the department. The engineer must pay all costs associated with on-site review.

(b) Every accredited engineer must continue to satisfy all the conditions specified in this chapter during the period of the accreditation. An engineer must furnish the department an annual report detailing the extent of its activities for the year. The report must include, but not be limited to:

(i) The number of industrial utilization equipment approved;

(ii) Organizational structure;

(iii) Statement of ownership; and

(iv) Reports of litigation, which in any way were the result of or may affect any accreditation or testing of products covered by this chapter.

(c) The department will notify the applicant of the accreditation results. A letter of accreditation from the department is proof of the accreditation of the engineer.

(10) The engineer will be approved to certify industrial utilization equipment.

#### **Suspension or revocation.**

(11) The department may suspend, revoke, or refuse to renew the department's accreditation of any engineer found to be in noncompliance with requirements of this chapter, the laws of the state of Washington, or submitting false information.

(12) The department will serve written notice of intent prior to suspension, revocation, or refusal to renew the accreditation of a laboratory.

(13) An engineer, whose accreditation has been suspended, may not reapply for accreditation during the period of such suspension. An engineer, whose accreditation has been revoked, may reapply for accreditation no sooner than two years after the date of revocation of accreditation.

#### **Business structure, practices, and personnel.**

(14) The engineer must be an independent, third-party organization with no organizational, managerial, financial, design, or promotional affiliation with owners, manufacturers, suppliers, installers, or vendors of products covered under the engineer's certification or evaluation programs.

The engineer must have an adequate diversity of clients or activity so that the loss or award of a specific contract regarding certification or evaluation would not be a deciding factor in the financial well-being of the engineer.

(15) The engineer must adequately meet the following business practices:

(a) Perform the examinations, tests, evaluations, and inspections required under the certifications programs in accordance with the designated standards and procedures;

(b) Assure that reported values accurately reflect measured and observed data;

(c) Limit work to that for which competence and capacity is available;

(d) Treat test data, records, and reports as proprietary information;

(e) Respond to and attempt to resolve complaints contesting certifications and evaluation results;

(f) Maintain an independent relationship between its clients, affiliates, and other organizations so the laboratory's capacity to give certifications and evaluations objectively and without bias is not adversely affected; and

(g) Notify the department within thirty calendar days should it become unable to conform to any of the requirements of this chapter.

(16) Engineers accredited under this chapter must notify the department within thirty calendar days of any of the following:

(a) Change in company name and/or address;

(b) Changes in major test equipment which affect the ability to perform work for which accredited; or

(c) Change in independent status.

(17) The engineer must develop and maintain a certification or evaluation program plan that includes, but is not limited to:

(a) The procedures and authority to ensure the product complies with the standard(s) established by the program;

(b) A quality control system;

(c) Verification and maintenance of facilities and/or equipment; or

(d) Sample selection as applicable for product certifications, and for component testing as necessary for evaluations.

The plan must demonstrate that the engineer has adequate facilities, and equipment to perform all certifications and testing for which it is accredited by the state of Washington. These elements must be contained in the engineer's operations control manual.

(18) The engineer must develop and maintain a quality control system adequate to assure the accuracy and technical integrity of its work as follows:

(a) The engineer's quality control system must include a quality control or engineer's operations control manual;

(b) The quality control or engineer's operations control manual must be adequate to guide a testing technician or inspector in conducting the inspection, evaluation, and/or test

in accordance with the test methods and procedures required for the engineer's certification and/or evaluation program(s); and

(c) The engineer must have a current copy of the quality control or laboratory operations control manual available for the engineer's use.

(19) The engineer must have training, technical knowledge, and experience adequate to perform the tests, examinations, and evaluations for the certification and/or evaluation activities for which recognition is sought.

(20) The engineer must:

(a) Provide adequate safeguards protecting the engineer's status from the influence or control of manufacturers, vendors, owners, or installers of electrical products certified or tested by the engineer; and

(b) Develop and maintain an adequate training program assuring that the engineer will be able to perform tasks properly and uniformly.

#### **Recordkeeping and reporting - general.**

(21) The engineer must develop and maintain records and reports of those testing, inspection, certification, and evaluation activities associated with each piece of industrial utilization equipment. The engineer must retain these records for a minimum of three years.

(22) The engineer must make available to the department, upon request, all records required by the department to verify compliance with this chapter.

(23) The engineer's evaluation report must include:

(a) Name and address of the engineer;

(b) Name of client;

(c) Address where the evaluated product is or will be installed;

(d) Designation of standards used to certify or test the product including edition and latest revision (e.g., UL 508, 16th Edition, Feb. 1993, Revision Oct. 9, 1997);

(e) Description of the overall product evaluated to include full nameplate data and equipment type;

(f) A statement as to whether or not the results comply with the requirements of the standard;

(g) Pertinent test evaluation data and identification of tests or inspections including anomalies;

(h) The engineer's stamp; and

(i) Any condition of acceptability or restrictions on use/relocation.

(24) Within thirty calendar days after affixing the evaluation mark, the engineer must submit a copy of the evaluation report to:

(a) The department's chief electrical inspector submitted electronically in a format approved by the department;

(b) Local electrical inspection office submitted electronically in a format approved by the department; and

(c) Client submitted in any format acceptable to the client and testing laboratory.

**AMENDATORY SECTION** (Amending WSR 05-10-024, filed 4/26/05, effective 6/30/05)

#### **WAC 296-46B-999 Electrical testing laboratory requirements. General.**

(1) This ~~((chapter))~~ section describes the methods required to obtain recognition and accreditation of electrical product(s) certification and/or field evaluation laboratories by the state of Washington. This ~~((chapter))~~ section provides assurance to the general consuming public that electrical products have been tested for safety and identified for their intended use.

(2) An electrical product is considered to be safe when it is either certified by a laboratory accredited by the department or labeled with a field evaluation mark by a laboratory accredited by the department.

(a) The department may declare electrical equipment unsafe if:

(i) The equipment is not being manufactured or produced in accordance with all standards of design and construction and all terms and conditions set out in the certification report for the equipment referred to in this chapter;

(ii) The equipment has been shown by field experience to be unduly hazardous to persons or property;

(iii) An examination of the equipment or of the certification report for the equipment shows that the equipment does not comply with all applicable standards; or

(iv) An examination of the certification report or the equipment shows that the equipment cannot be installed in accordance with this chapter.

(b) When the department declares an electrical product unsafe, the department will:

(i) Notify the product manufacturer and the appropriate testing laboratory in writing;

(ii) Notify the general public by:

(A) Report to the Consumer Product Safety Commission;

(B) A published article in the *Electrical Currents*;

(C) Internet web site posting; and/or

(D) News release.

#### **Accreditation - general.**

(3) The department's chief electrical inspector's office reviews requests for accreditation or evaluation. Applicants must submit supporting data ~~((as outlined in subsections (4) through (54)))~~ to document and verify the requirements of this section have been met.

(4) The accreditation ~~((period))~~ of a NRTL will be valid for the period of the laboratory's current OSHA NRTL accreditation. The accreditation of a non-NRTL will be valid for the period of five years from the date of the department's accreditation.

(5) On-site inspection of a laboratory.

(a) On-site inspection of the laboratory may be required during the initial application process or the renewal process. Technically qualified representative(s) of the department will evaluate for compliance with accreditation criteria.

(b) On-site inspection is not required for NRTL-recognized laboratories requesting approval as certification laboratories using standards for which NRTL recognition has been approved.

(c) The department may waive on-site inspection for:

(i) Laboratories recognized or accredited by another state determined to provide an accreditation program acceptable to the department; or

(ii) NRTL-recognized laboratories requesting approval as certification laboratories for using other standards for which NRTL recognition has not been approved.

(d) The applicant must pay all costs associated with the on-site inspection.

(6) For purposes of chapter 19.28 RCW, all laboratories which certify and/or field evaluate electrical products offered for sale in the state of Washington must be accredited by the department. A NRTL requesting approval as a certification laboratory will be approved for accreditation by the department upon completion of the application process.

(7) Fees are payable as required in WAC 296-46B-911.

(8) The laboratory must apply for renewal of accreditation at least thirty days prior to the accreditation expiration date. The department will renew accreditation for the period specified in subsection (4) of this section or notify the renewing laboratory of the department's reason(s) of refusal following receipt of the completed form and renewal fee. Accreditation may be renewed or refused for one or more electrical product category(ies).

(9) The department accepts or denies laboratory accreditation for all laboratories within the state. Accreditation is determined when a laboratory provides evidence to the department that all the requirements of this chapter are met. Accreditation is determined by the department and prior to making a determination, the department may require information and documentation to be provided by the laboratory.

(a) Accreditation is subject to review when deemed necessary by the department. The laboratory must pay all costs associated with on-site review.

(b) Every accredited laboratory must continue to satisfy all the conditions specified in this chapter during the period of the accreditation. A non-NRTL accredited laboratory must furnish the department an annual report detailing the extent of its activities for the year. The report must include, but not be limited to:

(i) The number of factory inspections;

(ii) Organizational structure of the laboratory;

(iii) Statement of ownership of the laboratory;

(iv) Laboratory equipment verification;

(v) Client accreditation programs;

(vi) Reports of litigation, which in any way were the result of or may affect any accreditation or testing of products covered by this chapter; or

(vii) Assessment of recordkeeping (i.e., certification/evaluation plans, certification/evaluation reports).

(c) The department will notify the applicant of the accreditation results. A letter of accreditation from the department is proof of the accreditation of a laboratory.

(10) The laboratory will be approved to certify only those categories identified and authorized by the department. The department will approve and list electrical product category(ies) the laboratory is qualified to certify or evaluate. The accreditation letter will indicate the electrical product category(ies) for which accreditation is issued.

(11) The department may exclude specific electrical products from acceptance. When required, the laboratory must provide evidence, acceptable to the department, that the laboratory is qualified to certify or field evaluate the specific electrical product. Laboratory recognition as an NRTL for the

standard(s) used to certify or field evaluate an electrical product will be acceptable evidence. The standards used for certification or field evaluation must be determined by the department to be acceptable and applicable to the electrical product being certified or field evaluated.

#### **Suspension or revocation.**

(12) Any laboratory failing to comply with the requirements of this chapter or submitting false information may have accreditation revoked or suspended for one or more electrical product category(ies).

(13) The department may suspend ~~((or))~~, revoke, or refuse to renew the accreditation of any laboratory found to be in noncompliance with this chapter or the laws of the state of Washington.

(14) The department will serve written notice of intent prior to suspension, revocation, or refusal to renew the accreditation of a laboratory.

(15) The laboratory must immediately notify all manufacturers whose products are covered by the accreditation that such products manufactured subsequent to the departmental revocation and offered for sale in the state of Washington can no longer bear the laboratory's label that identified it as a certified product in the state of Washington. A laboratory, whose accreditation has been suspended, may not reapply for accreditation during the period of such suspension. A laboratory, whose accreditation has been revoked, may reapply for accreditation no sooner than one year after the date of revocation of accreditation.

#### **Business structure, practices, and personnel.**

(16) The laboratory must be an independent, third-party organization with no organizational, managerial, financial, design, or promotional affiliation with manufacturers, suppliers, installers, or vendors of products covered under its certification or evaluation programs.

The laboratory must have an adequate diversity of clients or activity so that the loss or award of a specific contract regarding certification or evaluation would not be a deciding factor in the financial well-being of the laboratory.

(17) The laboratory must adequately meet the following business practices:

(a) Perform the examinations, tests, evaluations, and inspections required under the certifications programs in accordance with the designated standards and procedures;

(b) Assure that reported values accurately reflect measured and observed data;

(c) Limit work to that for which competence and capacity is available;

(d) Treat test data, records, and reports as proprietary information;

(e) Respond and attempt to resolve complaints contesting certifications and evaluation results;

(f) Maintain an independent relationship between its clients, affiliates, and other organizations so the laboratory's capacity to give certifications and evaluations objectively and without bias is not adversely affected; and

(g) Notify the department within thirty calendar days should it become unable to conform to any of the requirements of this chapter.



(18) Laboratories accredited under this chapter must notify the department within thirty calendar days of any of the following:

- (a) Change in company name and/or address;
- (b) Changes in major test equipment which affect the ability to perform work for which accredited;
- (c) Changes in principal officers, key supervisory and responsible personnel in the company including the director of testing and engineering services, director of follow-up services, and the laboratory supervisor; or
- (d) Change in independent status.

(19) The laboratory must develop and maintain a certification or evaluation program plan that includes, but is not limited to:

- (a) The procedures and authority to ensure the product complies with the standard(s) established by the program;
- (b) A quality control system;
- (c) Adequate personnel to perform the certification or evaluation;
- (d) Verification and maintenance of facilities and/or equipment; or
- (e) Sample selection as applicable for product certifications, and for component testing as necessary for field evaluations.

The plan must demonstrate that the laboratory has adequate personnel, facilities, and equipment to perform all certifications and testing for which it is accredited by the state of Washington. These elements must be contained in the laboratory operations control manual.

(20) The laboratory must develop and maintain a quality control system adequate to assure the accuracy and technical integrity of its work as follows:

- (a) The laboratory's quality control system must include a quality control or laboratory operations control manual;
- (b) The quality control or laboratory operations control manual must be adequate to guide a testing technician or inspector in conducting the inspection, evaluation, and/or test in accordance with the test methods and procedures required for the laboratory's certification and/or evaluation program(s); and
- (c) The laboratory must have a current copy of its quality control or laboratory operations control manual available in the laboratory for use by laboratory personnel.

(21) Competent personnel who must have training, technical knowledge, and experience adequate to perform the tests, examinations, and evaluations for the certification and/or evaluation activities for which recognition is sought must staff the laboratory.

(22) The laboratory must:

- (a) Provide adequate safeguards protecting the employment status of personnel from the influence or control of manufacturers, vendors, or installers of electrical products certified or tested by the laboratory;
- (b) Develop and maintain a job description for each technical position category;
- (c) Ensure the competency of its staff to perform assigned tasks through individual yearly observation and/or examination by a person(s) qualified by the person who has technical responsibility for the laboratory;

(d) Develop and maintain records of the results and dates of the observation or examination of personnel performance;

(e) Maintain information on the training, technical knowledge, and experience of personnel; and

(f) Develop and maintain an adequate training program assuring that new or untrained personnel will be able to perform assigned tasks properly and uniformly.

#### **Recordkeeping and reporting - general.**

(23) The laboratory must develop and maintain records and reports of those testing, inspection, certification, and evaluation activities associated with each program for which accreditation is sought. The laboratory must retain these records for a minimum of three years.

(24) The laboratory must make available to the department, upon request, all records required by the department to verify compliance with this chapter.

#### **Recordkeeping and reporting - certification.**

(25) Certification reports must contain, as applicable:

- (a) Name and address of the laboratory;
- (b) Pertinent data and identification of tests or inspections;
- (c) Name of client;
- (d) Appropriate product title;
- (e) Designation of standards used to certify or test the product including edition and latest revision (e.g., UL 508, 16th Edition, Feb. 1993, Revision Oct. 9, 1997);
- (f) Description and identification of the sample including, as necessary, where and how the sample was selected;
- (g) Identification of the test, inspection, or procedure as specified for certification or evaluation by the standard;
- (h) Known deviations, additions to, or exclusions from evaluation and certification activities in order to be appropriate for new or innovative products not contemplated by the standard;
- (i) Measurements, examinations, derived results, and identification of test anomalies;
- (j) A statement as to whether or not the results comply with the requirements of the standard;
- (k) Name, contact information, and signature of person(s) having responsibility for the report;
- (l) Raw data, calculations, tables, graphs, sketches, and/or photographs generated during certification or evaluation must be maintained if not included in the report;
- (m) Control forms documenting the receipt, handling, storage, shipping, and testing of samples;
- (n) Laboratory records of its quality control checks and audits for monitoring its test work associated with its certification programs, including:
  - (i) Records of products assurance (follow-up) test results; and
  - (ii) Records of detected errors and discrepancies and actions taken subsequent to such detection.
- (o) Record of written complaints and disposition thereof; and
- (p) A statement that records required by these criteria will be maintained for a minimum of three years after cessation of the certification or evaluation.

**Recordkeeping and reporting - field evaluation.**

- (26) The evaluation report must include:
- (a) Name and address of the laboratory;
  - (b) Name of client;
  - (c) Address where the evaluated product is or will be installed;
  - (d) Designation of standards used to certify or test the product including edition and latest revision (e.g., UL 508, 16th Edition, Feb. 1993, Revision Oct. 9, 1997);
  - (e) Description and identification of the nonlisted and nonlabeled component(s) requiring evaluation by applicable standard(s);
  - (f) Description of the overall product evaluated to include full nameplate data and equipment type;
  - (g) A statement as to whether or not the results comply with the requirements of the standard;
  - (h) Pertinent test evaluation data and identification of tests or inspections including anomalies;
  - (i) Signature of person(s) having responsibility for the report;
  - (j) Any condition of acceptability or restrictions on use/relocation;
  - (k) Serial number(s) of the field evaluation label(s) applied must be included with the equipment identification; and
  - (l) The labor and industries department file identification number;
- (27) Within thirty calendar days after affixing the evaluation mark, the laboratory must submit a copy of the evaluation report to:
- (a) The department's chief electrical inspector submitted electronically in a format approved by the department;
  - (b) Local electrical inspection office submitted electronically in a format approved by the department; and
  - (c) Client submitted in any format acceptable to the client and testing laboratory.

**Facilities and equipment.**

- (28) The laboratory must provide adequate evidence of the calibration, verification, and maintenance of the facilities and equipment specified for each certification or evaluation.
- (29) Verification and maintenance of facilities and equipment must include as applicable, but not be limited to:
- (a) Equipment description;
  - (b) Name of manufacturer;
  - (c) Model, style, serial number, or other identification;
  - (d) Equipment variables subject to calibration and verification;
  - (e) Statement of the equipment's allowable error and tolerances of readings;
  - (f) Calibration or verification procedure and schedule;
  - (g) Dates and results of last calibrations or verifications;
  - (h) Specified maintenance practices;
  - (i) Calibration and/or verification of equipment used;
  - (j) Name and contact information of personnel or outside contractor providing the calibration or verification service; and
  - (k) Traceability to National Institute of Standards and Technology or other equivalent standard reference authority.

**Standards.**

- (30) The laboratory must have copies available, for laboratory personnel use, of applicable standards and other documents referred to or used in performing each certification or test for which approval is sought.
- (31) If a laboratory desires to use a standard other than an ANSI standard, the department will evaluate the proposed standard to determine that it provides an adequate level of safety. The National Electrical Code, NFPA 70, will not be allowed to be the primary standard used to evaluate a product.

**Product certification.**

- (32) The electrical product certification program must contain test procedure(s), standard(s) used, certification agreement(s), method(s) of identification of products, follow-up inspection, and other laboratory procedures and authority necessary to ensure that the product complies with the standards (requirements) established by the program.
- (33) All components of certified or tested products must be labeled or evaluated for compliance with all standards and conditions of use applicable to such components.
- (34) The laboratory must publish an *Annual Product Directory* identifying products that are authorized to bear the laboratory's certification mark. The products directory must briefly describe the program, the products covered, the name of the manufacturer or vendor of the certified products, and the identification of the published standards or the compiled requirements on which the program is based. The product directory must be available to the public. Supplemental up-to-date information must be available to the public at the office of the laboratory during normal business hours.

**Certification laboratory/manufacturer - agreement.**

- (35) Measures to provide for manufacturer compliance with the provisions of the product standard and laboratory control of the use of the certification mark must be embodied in an agreement between the manufacturer and the certification laboratory. The certification agreement must:
- (a) Require the manufacturer to provide information and assistance as needed by the laboratory to conduct the necessary product conformity and production assurance evaluation;
  - (b) Allow the laboratory's representative(s) access to the manufacturer's facilities during working hours for inspection and may allow audit activities without prior notice;
  - (c) Restrict the manufacturer's application of certification marks to products that comply with requirements of the product standard;
  - (d) Secure the manufacturer's agreement to the publication of notice by the certification laboratory for any product already available in the marketplace that does not meet the safety standard;
  - (e) Require reevaluation of products whenever the standard covering the product is revised;
  - (f) Require the laboratory to notify the manufacturer's personnel responsible for and authorized to institute product recall in the case of a hazard;

(g) Provide for control of certification marks by the laboratory;

(h) Require that the laboratory provide the manufacturer with a report of original product evaluation. The report must document conformity with applicable product standards by test results and other data; and

(i) Require the identification of the manufacturer(s) of the product and the location(s) where the product is produced.

#### **Certification mark.**

(36) The laboratory owns the certification mark.

(37) The certification mark must be registered as a certification mark with the United States Patent and Trademark Office.

(38) The certification mark must:

(a) Not be readily transferable from one product to another;

(b) Be directly applied to each unit of production in the form of labels or markings suitable for the environment and use of the product. When the physical size of the unit does not permit individual marking, markings may be attached to the smallest package in which the unit is marketed;

(c) Include the name or other appropriate identification of the certification laboratory;

(d) Include the product category; and

(e) The laboratory must have a system of controls and records for all marks. The records must include marks removed or otherwise voided. See WAC 296-46B-999(25).

(39) The certification mark may be applied to the product prior to authorizing the use of a certification mark on a product. The laboratory must:

(a) Determine by examination and/or tests that representative samples of the product comply with the requirements (standards). Components of certified products must comply with the applicable safety requirements (standards) or be listed. Evaluation of the product design must be made on representative production samples or on prototype product samples with subsequent verification that factory productions are the same as the prototype;

(b) Determine that the manufacturer has the necessary facilities, test equipment, and control procedures to ensure that continuing production of the product complies with the requirements; and

(c) If the certification mark is not applied at the manufacturing facility, the laboratory must provide prior notification to the department of its intent to affix the certification mark in the field.

#### **Certification laboratory product - assurance/follow up.**

(40) To verify continued product acceptability, the laboratory must develop and maintain a factory follow-up inspection program and manual to determine continued compliance of certified products with the applicable standard.

(41) The follow-up inspection file must include the:

(a) Conditions governing the use of the certification mark on products;

(b) Identification of the products authorized for certification;

(c) Identification of manufacturer and plant location at which manufacture and certification are authorized;

(d) Description, specifications, and requirements applicable to the product;

(e) Description of processes needed for control purposes;

(f) Description of the manufacturer's quality assurance program when used as part of the follow-up program;

(g) Description of inspections and tests to be conducted by the manufacturer and the laboratory; and

(h) Description of follow-up tests to be conducted in the laboratory.

(42) Follow-up procedures and activities must include:

(a) Periodic inspections at the factory with testing at the factory or certification laboratory of representative samples selected from production and, if appropriate, from the market;

(b) Periodic auditing or surveillance of the manufacturer's quality assurance program through the witnessing of manufacturer's tests, review of the manufacturer's records, and verification of the manufacturer's produced data;

(c) Investigation of alleged field failures upon department request; and

(d) Procedures for control of the use of the certification mark by:

(i) Keeping records of the release and use of certification marks;

(ii) Removal of marks from noncomplying products;

(iii) Return or destruction of unused marks when the authority to use the marks is terminated; and

(iv) Legal action.

(43) The frequency of laboratory follow-up inspections must not be less than four times per year during production, unless adequate data is provided to the department to justify less frequent inspections. If there is no production during the year, at least one follow-up inspection is to be completed. The frequency of follow-up inspections must be sufficient to provide a reasonable check on the method(s) the manufacturer exercises to assure that the product bearing the certification mark complies with the applicable standards.

#### **Field evaluation - requirements.**

(44) The field evaluation laboratory may perform evaluations on any products or product categories previously approved by the department. NRTL recognition may be accepted by the department as a basis for approval to perform field evaluations. Since OSHA does not review or recognize laboratories for field evaluation purposes, laboratories seeking accreditation from the department for field evaluation may be required to provide additional justification of capability such as, but not limited to: Recordkeeping, employee standards and proficiency, equipment requirements, and other requirements described in this chapter.

(45) The laboratory must request permission from the department in writing two working days prior to conducting any field evaluation of an electrical product to be installed in any jurisdiction in the state. Requests must be made using a department-supplied form.

(46) The field evaluation process must be completed within six months following department approval. If the field evaluation is not completed within six months following

department approval, the laboratory must request permission from the department in writing to continue the evaluation process. If this secondary permission is granted to the laboratory, the department may require the equipment to be placed out-of-service except as necessary to complete the field evaluation process.

(47) The scope of a field evaluation will depend on the status of the item to be evaluated as follows:

(a) A new piece of equipment must have a complete evaluation of all components and the assembly as provided by the manufacturer. For example: An industrial machine with a control panel, remote motors, sensors, controls, and other utilization equipment; and

(b) A product that has been modified internally or by an addition need have only those portions evaluated that were affected by the modification. For example: A switchboard with multiple sections that has a section added would only need the new section, the one section immediately adjacent, and any control modifications evaluated.

(48) Each unit that receives a field evaluation mark applied by the field evaluation laboratory must have sufficient inspections and/or testing completed to ensure it is in essential conformance with the applicable product standard(s).

(49) The laboratory may perform the preliminary evaluation in the manufacturer's facility. Final evaluation and acceptance of the product must be made on-site at the location of final installation, unless waived by the department.

#### Field evaluation mark.

(50) Only laboratory personnel may apply the field evaluation mark after final acceptance of the product. The field evaluation label must be applied on-site at the location of the final installation, unless waived by the department.

(51) The field evaluation laboratory must have a system of controls and records for all field evaluation marks it applies. The records must include labels removed or otherwise voided.

(52) A field evaluated product may be relocated or fed from a different power source if not prohibited by the field evaluation mark or the field evaluation report.

(53) The field evaluation mark must:

(a) Not be readily transferable from one product to another;

(b) Be directly applied by the laboratory personnel to each unit of production in the form of labels or markings suitable for the environment and use of the product;

(c) Include the name or other appropriate identification of the certification laboratory; and

(d) Include a unique evaluation laboratory reference number.

(54) The field evaluation laboratory must have a system of controls and records for all field evaluation marks it applies. The records must include labels removed or otherwise voided. See subsection (26) of this section.

#### REPEALER

The following sections of the Washington Administrative Code are repealed:

WAC 296-46B-950	Opportunity for gaining credit for previous work experience gained in certain specialties.
WAC 296-46B-955	Appliance repair specialty electrician enforcement procedures.

#### **WSR 05-24-088**

#### **PROPOSED RULES**

#### **OFFICE OF**

#### **INSURANCE COMMISSIONER**

[Insurance Commissioner Matter No. R 2005-02—Filed December 6, 2005, 3:02 p.m.]

Original Notice.

Preproposal statement of inquiry was filed as WSR 05-17-163.

Title of Rule and Other Identifying Information: Property and casualty statistical plans.

Hearing Location(s): John L. O'Brien Building, Hearing Room C, 504 15th Avenue S.W., Olympia, WA 98504, on April 5, 2006, at 10:00 a.m.

Date of Intended Adoption: June 15, 2006.

Submit Written Comments to: Kacy Scott, P.O. Box 40255, Olympia, WA 98504-0258, e-mail Kacys@oic.wa.gov, fax (360) 586-3109, by April 4, 2006.

Assistance for Persons with Disabilities: Contact Lorie Villaflores by March 31, 2006, TTY (360) 586-0241 or (360) 725-7087.

Purpose of the Proposal and Its Anticipated Effects, Including Any Changes in Existing Rules: RCW 48.19.370 requires the commissioner to adopt rules and statistical plans for property and casualty insurance. WAC 284-24-015 has not been amended since 1998, and includes information that is no longer accurate. WAC 284-24-015 is repealed and replaced with chapter 284-24B WAC that sets forth a process for insurers to report insurance statistical data and for qualifying entities to be designated as statistical agents. In addition, a new chapter 284-24C WAC prescribes specific data elements that medical malpractice insurers must report to statistical agents. These data elements will assist the commissioner to determine if rating elements comply with RCW 48.19.020 and 48.19.030, and will provide information the commissioner needs to monitor the condition of this market.

Reasons Supporting Proposal: Statistical reporting has been required under RCW 48.19.370 since 1947. These rules update processes and procedures under which insurers report data. These rules are consistent with processes and procedures adopted by the National Association of Insurance Commissioners.

Statutory Authority for Adoption: RCW 48.02.060, 48.19.370.

Statute Being Implemented: RCW 48.19.370.

Rule is not necessitated by federal law, federal or state court decision.

Name of Proponent: Mike Kreidler, Insurance Commissioner, governmental.

Name of Agency Personnel Responsible for Drafting: Lisa Smego, P.O. Box 40255, Olympia, WA 98504-0255, (360) 725-7134; Implementation: Beth Berendt, P.O. Box 40255, Olympia, WA 98504-0255, (360) 725-7117; and Enforcement: Carol Sureau, P.O. Box 40255, Olympia, WA 98504-0255, (360) 725-7050.

No small business economic impact statement has been prepared under chapter 19.85 RCW. There is no impact on small business as defined under RCW 19.85.020(1).

A cost-benefit analysis is required under RCW 34.05.328. A preliminary cost-benefit analysis may be obtained by contacting Kacy Scott, Insurance Building, 302 14th Avenue S.W., P.O. Box 40254, Olympia, WA 98504-0258, phone (360) 725-7041, fax (360) 586-3109, e-mail KacyS@oic.wa.gov.

December 1, 2005

Mike Kreidler

Insurance Commissioner

### Chapter 284-24B WAC

#### RULES THAT REQUIRE PROPERTY AND CASUALTY INSURERS TO REPORT STATISTICAL DATA

##### NEW SECTION

**WAC 284-24B-010 Definitions that apply to these rules.** (1) **"Insurer"** means an authorized insurer that has premium, loss or loss adjustment expense data in Washington state for one or more of these lines of insurance:

- (a) Property, as defined in RCW 48.11.040;
- (b) Marine and transportation, as defined in RCW 48.11.050, if not exempt from statistical reporting under RCW 48.19.010 (1)(e);
- (c) Vehicle, as defined in RCW 48.11.060;
- (d) General casualty, as defined in RCW 48.11.070; and
- (e) Surety, as defined in RCW 48.11.080.

(2) **"NAIC Statistical Handbook"** is a publication of the National Association of Insurance Commissioners (NAIC) that explains insurance statistical data and provides reporting requirements and report formats for data that statistical agents must submit to the commissioner.

(3) **"Statistical agent"** means an entity that the commissioner has designated under RCW 48.19.370(4) to collect insurance statistical data from insurers and report these data to the commissioner on behalf of those insurers.

(4) **"Statistical plan"** means a system for collecting information from insurers.

##### NEW SECTION

**WAC 284-24B-020 Purpose.** (1) The purpose of this chapter is to:

- (a) Incorporate the provisions of the *NAIC Statistical Handbook* into this chapter;

(b) Prescribe the manner of reporting statistical and the types of statistical data insurers must submit to statistical agents under RCW 48.19.370; and

(c) Establish a procedure for the commissioner to designate statistical agents under RCW 48.19.370.

(2) This chapter does not limit the powers granted to the commissioner by any law of this state.

##### NEW SECTION

**WAC 284-24B-030 The commissioner adopts certain statistical plans.** (1) By reference, the commissioner incorporates the provisions of the *NAIC Statistical Handbook* into this rule, except:

(a) Medical Professional Liability Reports: Statistical Plan Reporting Requirements; and

(b) Medical Professional Liability Reports: Model Medical Professional Liability Statistical Plan.

(2) The commissioner will issue a technical assistance advisory to notify insurers and statistical agents of the effective date of any revisions to the *NAIC Statistical Handbook*.

##### NEW SECTION

**WAC 284-24B-040 Insurers must report statistical experience.** (1) Under RCW 48.19.370(4), the commissioner may designate certain rating organizations or other entities as statistical agents to gather, compile, and report insurance statistical data.

(2) RCW 48.19.370 says each insurer must report loss and expense experience to the commissioner. As a condition of transacting the business of insurance under RCW 48.05.040, each insurer must:

(a) Report its insurance statistical data to a statistical agent designated by the commissioner in accordance with the statistical plans filed with the commissioner by the statistical agent in WAC 284-24B-060;

(b) Comply with the reporting requirements and data quality procedures in the *NAIC Statistical Handbook*; and

(c) Adopt edit and audit procedures to screen and check data for reasonableness and accuracy.

(3) So the commissioner may assure compliance with this chapter, each insurer filing rates under chapter 48.19 RCW must include the name of its statistical agent for that line of insurance.

##### NEW SECTION

**WAC 284-24B-050 Process for an entity to be designated a statistical agent.** The commissioner may designate an entity as a statistical entity if the entity makes a written request to the commissioner that:

(1) Identifies the line(s) of business for which the entity will collect and report statistical experience;

(2) States the entity's qualifications to act as a statistical agent; and

(3) Agrees to:

(a) Comply with the reporting requirements and data quality procedures in the *NAIC Statistical Handbook*, and all rules, technical advisories and directives issued by the commissioner;

(b) Report statistical data to the commissioner in a timely manner; and

(c) Submit to an examination in accordance with procedures described in RCW 48.03.010.

#### NEW SECTION

**WAC 284-24B-060 Statistical agents must file their statistical plans with the commissioner.** Entities that are designated as statistical agents under WAC 284-24B-050 must file with the commissioner:

(1) Their statistical plans, including standard report formats; and

(2) All changes in their statistical plans or reporting formats.

#### NEW SECTION

**WAC 284-24B-070 Statistical agents must comply with the NAIC Statistical Handbook.** Statistical agents must collect statistical data in a form and detail as required by the *NAIC Statistical Handbook* and any additional detail required by rules adopted by the commissioner.

#### NEW SECTION

**WAC 284-24B-080 Multiple statistical agents for the same line of insurance.** If the commissioner designates more than one statistical agent to collect statistical data for a particular line of insurance, those statistical agents must arrange to file reports that combine all data collected by the statistical agents for that line(s) of insurance. The statistical agents may arrange among themselves for the equitable sharing of the costs to produce combined reports.

#### NEW SECTION

**WAC 284-24B-090 Access to data.** The commissioner shall have access to all statistical data that statistical agents collect to comply with this chapter. If requested by the commissioner, statistical agents must promptly provide a copy of any report produced from data that the statistical agent is required to collect under this chapter.

#### NEW SECTION

**WAC 284-24B-100 Disclosure of data.** (1) Aggregate data reported to the commissioner by statistical agents are available for public inspection.

(2) If data submitted to the commissioner by a statistical agent appear likely to identify individual insurers, claimants or insureds, or the statistical agent or an insurer asserts that data are exempt from public disclosure under RCW 48.02.-120(3), such data may not be publicly disclosed until the commissioner:

(a) Notifies the statistical agent and any insurer that has asserted the data to be exempt from public disclosure of the disclosure request;

(b) Provides a thirty-day period from the date of notice for any insurer that reported data to the statistical agent to

assert that its data are trade secrets or are otherwise protected from disclosure; and

(c) Provides aggrieved insurers with the opportunity to request a hearing under RCW 48.04.010 and chapter 34.05 RCW.

### Chapter 284-24C WAC

#### SPECIFIC RULES THAT APPLY TO STATISTICAL PLANS FOR MEDICAL PROFESSIONAL LIABILITY REPORTS

#### NEW SECTION

**WAC 284-24C-010 Definitions that apply to these rules.** (1) "**Medical malpractice insurer**" means an authorized general casualty insurer that has premium, loss or loss adjustment expense data for medical malpractice insurance.

(2) "**Medical professional liability insurance**" or "**medical malpractice insurance**" provides coverage for tort claims brought against various medical-related institutions and medical professionals, such as:

(a) Institutions, including hospitals, infirmaries, nursing homes, mental institutions, blood banks, sanitariums, and clinics; and

(b) Individual medical professionals including physicians, surgeons, dentists, nurses, pharmacists, opticians, optometrists, physiotherapists, chiropractors, laboratory technicians, and various specialists.

(3) "**Medical malpractice statistical agent**" means an organization designated by the commissioner under RCW 48.19.370(4) to gather, compile and report medical malpractice statistical data.

(4) "**NAIC Statistical Handbook**" is a publication of the National Association of Insurance Commissioners (NAIC) that explains insurance statistical data and provides reporting requirements and report formats for data that statistical agents must submit to the commissioner.

(5) "**Statistical plan**" means a system for collecting information from insurers.

#### NEW SECTION

**WAC 284-24C-020 Purpose.** (1) The purpose of this chapter is to:

(a) Incorporate the provisions of chapter 284-24B WAC into this chapter;

(b) Prescribe the manner of reporting statistical data and the types of statistical data medical malpractice insurers must submit to statistical agents under RCW 48.19.370; and

(c) Establish a medical professional liability statistical plan.

(2) This chapter does not limit the powers granted to the commissioner by any law of this state.

#### NEW SECTION

**WAC 284-24C-030 Statistical reporting for medical professional liability insurance.** Each medical malpractice insurer must:

- (1) Comply with the provisions of RCW 48.19.370 and chapter 284-24B WAC; and
- (2) Report its insurance statistical data to a statistical agent designated by the commissioner in accordance with the statistical plans filed by the statistical agent under WAC 284-24B-060 and all additional detail required by this chapter.

#### NEW SECTION

**WAC 284-24C-040 NAIC Statistical Handbook—Medical professional liability statistical plan reporting requirements.** These data items, as specified by the *NAIC Statistical Handbook*, must be reported by each medical malpractice insurer to a medical malpractice statistical agent:

(1) Company number: Experience must be reported by the company number assigned by the medical malpractice statistical agent. Medical malpractice statistical agents must convert each company number to NAIC group and company code numbers.

- (2) Accounting/calendar date:
- (a) Accounting quarter (where applicable).
  - (b) Accounting year.
- (3) Transaction identifier and amounts. Identify the following items and their respective amounts:
- (a) Written premium.
  - (b) Paid losses.
  - (c) Paid allocated loss adjustment expenses.
  - (d) Outstanding losses.
  - (e) Outstanding allocated loss adjustment expense.
- (4) Subline identifier:
- (a) Hospital professional and other health care facilities liability.
  - (b) Physicians, surgeons, and dentists professional liability.
  - (c) Other health care professional liability.
  - (d) All composite rated risks.
  - (e) Indivisible premium policy experience.
- (5) Classification codes. Individual industry classification codes describing specific coverage. In Washington, the current Insurance Services Office (ISO) five digit common statistical base classifications must be used.
- (6) State indicator.
- (7) Policy effective year:
- (a) The effective date of the policy, defined as the beginning date of the declarations page or renewal certificate.
  - (b) For claims-made tail coverage, the date on which tail coverage began is required.
- (8) Type of program indicator:
- (a) Monoline; or
  - (b) Package.
- (9) Date of entry into the claims-made program:
- (a) The date of entry into the claims-made program is the retroactive date employed in claims-made coverage in order to exclude coverage for occurrences that took place prior to that date even though claims resulting from such occurrences are made within the policy period.
  - (b) Claims-made tail coverage records must include, in the date of entry into the claims-made program field, the date applicable to the basic and excess coverage.
- (10) Type of policy contract identifier:

- (a) Claims-made coverage - basic and excess.
- (b) Claims-made coverage - tail.
- (c) Occurrence coverage.

(11) Exposures. The applicable exposure is required for each of the subdivisions of experience for which separate classification codes and exposure bases exist. The current Insurance Services Office (ISO) exposure reporting basis included with the common statistical base classifications must be used.

#### NEW SECTION

**WAC 284-24C-050 Additional medical professional liability statistical plan reporting requirements required by the commissioner.** In addition to the data items specified by the *NAIC Statistical Handbook*, these data items, specific to this medical malpractice statistical plan rule, must be reported by each medical malpractice insurer to a medical malpractice statistical agent:

- (1) Claim dates:
- (a) Incident month/year; and
  - (b) Report month/year.
- (c) Closed month/year (closed claims only).
- (2) Additional transaction identifiers and details. Identify the following items and their respective amounts:
- (a) Paid losses segmented by amounts paid or incurred for past and future:
    - (i) Wage loss;
    - (ii) Medical expenses; and
    - (iii) All other losses.
  - (b) Paid allocated loss adjustment expenses segmented by amounts paid for:
    - (i) Defense counsel;
    - (ii) Expert witness; and
    - (iii) All other allocated loss adjustment expenses.
  - (c) Outstanding losses segmented by amounts paid or incurred for past and future:
    - (i) Wage loss;
    - (ii) Medical expenses; and
    - (iii) All other losses.
  - (d) Outstanding allocated loss adjustment expense segmented by amounts paid or incurred for:
    - (i) Defense counsel;
    - (ii) Expert witness; and
    - (iii) All other allocated loss adjustment expenses.
- (3) Policy limit per incident.
- (4) Deductible or retention.
- (5) Medical outcome classifications (use only one code):
- (a) Emotional only: Fright, no physical damage.
  - (b) Temporary: Slight - lacerations, contusions, minor scars, rash. No delay.
  - (c) Temporary: Minor - infections, mis-set fracture, fall in hospital. Recovery delayed.
  - (d) Temporary: Major - burns, surgical material left, drug side effect, brain damage. Recovery delayed.
  - (e) Permanent: Minor - loss of fingers, loss or damage to organs. Includes nondisabling injuries.
  - (f) Permanent: Significant - deafness, loss of limb, loss of eye, loss of one kidney or lung.

(g) Permanent: Major - paraplegia, blindness, loss of two limbs, brain damage.

(h) Permanent: Grave - quadriplegia, severe brain damage, lifelong care or fatal prognosis.

(i) Permanent: Death.

(6) Act or omission classification, as follows:

(a) Diagnosis related;

(b) Anesthesia related;

(c) Surgery related;

(d) Medication related;

(e) Intravenous and/or blood products related;

(f) Obstetrics related;

(g) Treatment related;

(h) Monitoring related;

(i) Biomedical equipment and/or product related;

(j) Behavioral health related; or

(k) All other.

(7) Injury location codes:

(a) Type of facility (use only one code):

(i) Blood bank.

(ii) Clinic (multiservice facility, including ambulatory surgical centers).

(iii) Hospital inpatient facility.

(iv) Hospital outpatient facility.

(v) Medical test site.

(vi) Nursing home.

(vii) Physician's office.

(viii) Patient's home.

(ix) Other outpatient facility.

(x) Other hospital/institutional location.

(xi) Other.

(b) Location of institutional injury (paid and closed claims only, use only one code):

(i) Critical care unit.

(ii) Emergency room.

(iii) Labor/delivery room.

(iv) Laboratory services.

(v) Nursery.

(vi) Operating room.

(vii) Patient room.

(viii) Physical therapy department.

(ix) Radiology.

(x) Special procedure room.

(xi) Other.

(8) Claim disposition (paid and closed claims only):

(a) Settled by parties (use only one code):

(i) Before filing suit or demanding hearing.

(ii) Before trial or hearing.

(iii) During trial or hearing.

(iv) After trial or hearing but before judgment or decision (award).

(v) After judgment or decision, but before appeal.

(vi) During appeal.

(vii) After appeal.

(viii) Claim or suit abandoned.

(ix) During review panel or nonbinding arbitration.

(b) Disposed of by a court (use only one code):

(i) No court proceedings.

(ii) Directed verdict for plaintiff.

(iii) Directed verdict for defendant.

(iv) Judgment notwithstanding the verdict (plaintiff).

(v) Judgment notwithstanding the verdict (defendant).

(vi) Judgment for the plaintiff.

(vii) Judgment for the defendant.

(viii) Decision for plaintiff on appeal.

(ix) Decision for defendant on appeal.

(x) All other.

(c) Disposed of by binding arbitration (use only one code).

(i) Claim not subject to arbitration.

(ii) Claim subject to arbitration, but previously coded disposition reached in lieu of award.

(iii) Award for plaintiff.

(iv) Award for defendant.

(d) Mediation.

(e) Private trial:

(i) Award for plaintiff.

(ii) Award for defendant.

(9) Territory indicator for principal location in which the incident of alleged medical malpractice occurred, including:

(a) County indicator; and

(b) City indicator.

#### NEW SECTION

**WAC 284-24C-060 Effective date.** Medical malpractice insurers must begin reporting statistical data specified by this chapter to medical malpractice statistical agent by January 1, 2007. Medical malpractice statistical agents must begin reporting calendar year 2007 data under these rules by April 1, 2008.

#### REPEALER

The following section of the Washington Administrative Code is repealed:

WAC 284-24-015

Statistical plans and designation of statistical agents.

#### **WSR 05-24-090**

#### **PROPOSED RULES**

#### **DEPARTMENT OF**

#### **SOCIAL AND HEALTH SERVICES**

(Aging and Disability Services Administration)

[Filed December 6, 2005, 3:28 p.m.]

Original Notice.

Preproposal statement of inquiry was filed as WSR 05-13-174.

Title of Rule and Other Identifying Information: Chapter 388-825 WAC, Division of Developmental Disabilities service rules, new WAC 388-825-500 through 388-825-595, promulgating rules governing the family support pilot program.

Hearing Location(s): Blake Office Park East, Rose Room, 4500 10th Avenue S.E., Lacey, WA 98503 (one block north of the intersection of Pacific Avenue S.E. and Alhadeff Lane, behind Goodyear Tire. A map or directions are avail-



able at <http://www1.dshs.wa.gov/msa/rpau/docket.html> or by calling (360) 664-6097, on January 10, 2006, at 10:00 a.m.

Date of Intended Adoption: Not earlier than January 11, 2006.

Submit Written Comments to: DSHS Rules Coordinator, P.O. Box 45850, Olympia, WA 98504, delivery 4500 10th Avenue S.E., Lacey, WA 98503, e-mail [fernaax@dshs.wa.gov](mailto:fernaax@dshs.wa.gov), fax (360) 664-6185, by 5:00 p.m., January 10, 2006.

Assistance for Persons with Disabilities: Contact Stephanie Schiller, DSHS Rules Consultant, by January 6, 2006, TTY (360) 664-6178 or (360) 664-6097 or by e-mail at [schilse@dshs.wa.gov](mailto:schilse@dshs.wa.gov).

Purpose of the Proposal and Its Anticipated Effects, Including Any Changes in Existing Rules: These rules are necessary to implement ESSB 6090, 2005-2007 Conference Budget (section 205 (1)(e), chapter 518, Laws of 2005), which establishes a flexible family support pilot program for families who are providing care and support for family members with developmental disabilities. The family support pilot program is funded through June 30, 2007.

Reasons Supporting Proposal: The Division of Developmental Disabilities (DDD) determined that new sections of chapter 388-825 WAC are necessary to implement the legislature's directive in ESSB 6090.

Statutory Authority for Adoption: RCW 71A.12.030, 71A.12.040.

Statute Being Implemented: Section 205 (1)(e), chapter 518, Laws of 2005, Title 71A RCW.

Rule is not necessitated by federal law, federal or state court decision.

Name of Proponent: Department of Social and Health Services, governmental.

Name of Agency Personnel Responsible for Drafting: Steve Brink, 640 Woodland Square Loop S.E., Lacey, WA 98503-1045, P.O. Box 45310, Olympia, WA 98507-5310, e-mail [brinksc@dshs.wa.gov](mailto:brinksc@dshs.wa.gov), (360) 725-3416; Implementation: Shirley Everard, 640 Woodland Square Loop S.E., Lacey, WA 98503-1045, P.O. Box 45310, Olympia, WA 98507-5310, e-mail [everash@dshs.wa.gov](mailto:everash@dshs.wa.gov), (360) 725-3444; and Enforcement: Colleen Erskine, 640 Woodland Square Loop S.E., Lacey, WA 98503-1045, P.O. Box 45310, Olympia, WA 98507-5310, e-mail [erskicm@dshs.wa.gov](mailto:erskicm@dshs.wa.gov), (360) 724-3452.

No small business economic impact statement has been prepared under chapter 19.85 RCW. DDD has determined that these rules do not impose additional costs on small businesses.

A cost-benefit analysis is required under RCW 34.05.328. A preliminary cost-benefit analysis may be obtained by contacting Steve Brink, 640 Woodland Square Loop S.E., Lacey, WA 98503-1045, P.O. Box 45310, Olympia, WA 98507-5310, phone (360) 725-3416, fax (360) 407-0955, e-mail [brinksc@dshs.wa.gov](mailto:brinksc@dshs.wa.gov).

November 29, 2005

Andy Fernando, Manager

Rules and Policies Assistance Unit

#### NEW SECTION

**WAC 388-825-500 What is the Family Support Pilot?** (1) The Family Support Pilot (FSP) is a new state-only program funded by the legislature to provide services in a new program through June 2007.

(2) The purpose of the Family Support Pilot is to provide paid services in a flexible manner to eligible DDD clients.

#### NEW SECTION

**WAC 388-825-505 What is the statutory authority for the Family Support Pilot?** The legislature directed DDD to implement the Family Support Pilot in the 2005-2007 conference budget, chapter 518, Laws of 2005 Section 205 (1)(e).

#### NEW SECTION

**WAC 388-825-510 Who is eligible to participate in the Family Support Pilot?** To be eligible to participate in the Family Support Pilot (FSP), you must meet all of the following criteria:

- (1) Be a client of DDD.
  - (a) Your eligibility must be current.
  - (b) WAC 388-823-1010 may require a review of your eligibility prior to any approval of paid services.
- (2) Be in DDD's current database as having requested FSP.
  - (3) Live with family as defined in WAC 388-825-512.
  - (4) Not be receiving any other DDD paid services as defined in WAC 388-825-516.
  - (5) Have been determined ineligible for Medicaid Personal Care (MPC).
  - (6) Have a gross household annual income of less than or equal to 400% of federal poverty level (FPL).
  - (7) Have completed a mini-assessment per chapter 388-824 WAC.

#### NEW SECTION

**WAC 388-825-512 What is the definition of family?** Family means relatives who live in the same home with the eligible client. Relatives include parents, grandparents, brother, sister, step-parent, step-brother, step-sister, uncle, aunt, first cousin, niece or nephew.

#### NEW SECTION

**WAC 388-825-513 What is the definition of an "award"?** (1) An award is the dollar amount of services performed by a provider for an eligible client.

(2) The award will be paid directly to the provider.

#### NEW SECTION

**WAC 388-825-514 If I participate in the FSP, will I be eligible for services through the DDD Home and Community Based Services (HCBS) waiver?** You may request to be served in the DDD HCBS waiver per WAC 388-845-0050 but waiver enrollment is limited by waiver capacity and

funding. Participation in the FSP will not affect your potential waiver eligibility.

NEW SECTION

**WAC 388-825-516 If I receive other DDD funded services do I qualify for the FSP?** You do not qualify for the FSP if any of the following apply:

- (1) You receive other DDD funded services identified in WAC 388-823-1015, including services through the DDD HCBS waiver per WAC 388-845-0050;
- (2) You are eligible for Medicaid Personal Care;
- (3) You receive the State Supplementary Payment administered by DDD; or
- (4) You are under age three. (All children under age three receive or are eligible to receive services through the Infant Toddler Early Intervention Program and/or child development services through DDD.)

NEW SECTION

**WAC 388-825-520 If I qualify for and receive an FSP award, will my name remain on the Family Support Waitlist?** Participation in the FSP does not remove your name from the family support waitlist.

NEW SECTION

**WAC 388-825-524 How do I apply for the FSP?** You may apply for the FSP by completing and returning an FSP

Household Size	100% FPL	200% FPL	300% FPL	400% FPL
One	\$9,570	\$19,140	\$28,710	\$38,280
Two	\$12,830	\$25,660	\$38,490	\$51,320
Three	\$16,090	\$32,180	\$48,270	\$64,360
Four	\$19,350	\$38,700	\$58,050	\$77,400
Five	\$22,610	\$45,220	\$67,830	\$90,440
Six	\$25,870	\$51,740	\$77,610	\$103,480
Seven	\$29,130	\$58,260	\$87,390	\$116,520
Eight	\$32,390	\$64,780	\$97,170	\$129,560
Nine	\$35,650	\$71,300	\$106,950	\$142,600
Ten	\$38,910	\$77,820	\$116,730	\$155,640

For each household member over ten, add the following amounts to the ten-person standard:

100% FPL	200% FPL	300% FPL	400% FPL
\$3,260	\$6,520	\$9,780	\$13,040

- (2) The FPL is updated each year in April.

NEW SECTION

**WAC 388-825-536 What is "gross annual household income"?** Gross annual household income means total unearned and earned income prior to any deductions or taxes for the past calendar year.

- (1) Ownership of income is defined in WAC 388-450-0005.

questionnaire that DDD will send to individuals and families who are on the family support waitlist as of August 1, 2005.

NEW SECTION

**WAC 388-825-528 What will DDD do with the FSP questionnaire that you return?** When you return the FSP questionnaire, DDD will determine your eligibility according to the criteria contained in WAC 388-825-510 and notify you of its decision according to WAC 388-825-588.

NEW SECTION

**WAC 388-825-532 How does DDD determine the federal poverty level (FPL) for my household?** DDD determines the federal poverty level (FPL) for your household by asking you for your gross annual household income and the number of people living in your household.

- (1) DDD cannot determine your financial eligibility for FSP without this information.
- (2) If you do not provide this information, you will not be eligible for FSP services.

NEW SECTION

**WAC 388-825-534 What are the annual federal poverty levels?** (1) The annual 2005 federal poverty levels (FPL) based on household size established by the federal Office of Management and Budget are:

- (2) Income that is not counted is defined in WAC 388-450-0015.
- (3) Unearned income is defined in WAC 388-450-0025.
- (4) Earned income is defined in WAC 388-450-0030.

NEW SECTION

**WAC 388-825-538 What is the definition of household?** For the purpose of determining household size and gross annual household income, the definition of household follows:

- (1) If you are under age eighteen, your household includes:
  - (a) You;
  - (b) Your full, half, step or adoptive siblings under age eighteen living with you; and

- (c) Your natural or adoptive parent(s) or stepparent(s) living with you.
- (2) If you are age eighteen or older, your household includes only you.

NEW SECTION

**WAC 388-825-540 Who must declare their income?**

If you are a child under age of eighteen at the time you are declaring income, your custodial, natural/step/adoptive parent(s) or guardian(s) must declare income.

- (2) If you are age eighteen or older, you are the only household member to declare income. You must report all unearned and earned income.
- (3) Income is subject to verification upon department request.

**Reviser's note:** The typographical error in the above section occurred in the copy filed by the agency and appears in the Register pursuant to the requirements of RCW 34.08.040.

NEW SECTION

**WAC 388-825-544 If I meet eligibility for FSP, will I receive paid services?** You will have access to an amount of paid services called an "FSP Award" if:

- (1) You are determined eligible by DDD to participate in FSP;
- (2) You meet one of the priority groups in WAC 388-825-554; and
- (3) There is funding available.

NEW SECTION

**WAC 388-825-548 What is the amount of the FSP Awards?** FSP Awards are based on your gross household income and the annual Federal Poverty Level (FPL) based on your household size and income.

Amount of Annual Income	Amount of Award
Equal to or less than 100% FPL	Up to \$4,000 per year
Greater than 100% but equal to or less than 200% FPL	Up to \$3,000 per year
Greater than 200% but equal to or less than 300% FPL	Up to \$2,000 per year
Greater than 300% but equal to or less than 400% FPL	Up to \$1,000 per year

NEW SECTION

**WAC 388-825-552 What if there are two or more family members who qualify for FSP?** Each family member who is eligible will be considered for an award.

NEW SECTION

**WAC 388-825-554 How will DDD determine who will receive awards for FSP?** Within the availability of staff time, DDD will distribute the awards to eligible FSP clients in order of the following priorities:

- (1) Client or caregiver with health and safety needs that places the client at immediate risk of out-of-home placement in a nursing facility or ICF/MR.

- (2) Clients living in single parent households;
- (3) Clients with multiple disabilities; and
- (4) Clients who are at least twenty-one years old and graduated from high school who need employment services.

NEW SECTION

**WAC 388-825-558 What FSP services can my family and I receive?** You and your family can use your FSP Award to pay for any of the following services identified and agreed to in your FSP service plan with DDD:

- (1) Respite care which is intermittent relief to your caregiver.
  - (a) Respite care may be provided in your home or the home of a relative or licensed provider, or community setting/activity contracted for respite care.
  - (b) The respite provider must be a qualified individual or agency per WAC 388-825-300 through WAC 388-825-400.
  - (c) Respite care may be provided by a registered or licensed nurse if you require a licensed health professional as determined by DDD.

(2) Training and consultation for you or your family, including:

- (a) Counseling related to your disability or genetic counseling.
- (b) Parenting classes and disability related support groups.
- (c) Behavior management/counseling.
- (3) Assistive technologies or specialized or adaptive equipment related to your development disability:

(a) Mobility devices such as walkers and wheelchairs are included, as well as communication devices and medical supplies such as diapers for children three years of age or older.

(b) Professional justifications may be required by the department.

(4) Employment services for those clients twenty-one years of age and older. See chapter 388-850 WAC.

(5) Extraordinary household expenses resulting from the client's developmental disability such as a portion of the power bill for a ventilator dependent client.

(a) The expense is limited to the total cost divided by the total number of persons living in the family.

(b) This will not include the purchase of any appliances, furniture, or floor coverings.

NEW SECTION

**WAC 388-825-560 What department restrictions apply to FSP?** The following department restrictions apply to FSP:

(1) FSP services are authorized only after you have accessed what is available to you under Medicaid, and any other private health insurance plan, school or child development services.

(2) All FSP service payments must be agreed to by DDD and the client in a written service plan.

(3) The department will contract directly with providers. FSP funding cannot be authorized for services or treatments determined by the department to be experimental.

(4) Your choice of qualified providers and services is limited to the most cost effective option that meets your assessed need.

(5) Respite care cannot be a replacement for child care while the parent or guardian is at work regardless of the age of the child.

(6) The department shall not authorize a birth parent, adoptive parent, step-parent or any other primary caregiver or their spouse living in the same household with the client to provide respite, nursing, therapy or counseling services.

(7) FSP will not pay for conference registrations.

(8) FSP will not pay for behavior management/counseling procedures, modifications, or equipment that are restrictive.

(9) FSP will not pay for services provided after the death of the eligible client. Payment may occur after the date of death, but not the service.

(10) FSP will not pay for employment services if you are under age twenty-one or are designated to receive DDD funded transition services.

#### NEW SECTION

**WAC 388-825-562 What is an FSP plan?** (1) An FSP plan is a written plan you develop with your DDD case resource manager that identifies the services you will purchase with your FSP Award.

(2) The FSP plan will last for up to twelve months, but cannot extend beyond June 30, 2007.

(3) The department has the final approval over service authorization.

#### NEW SECTION

**WAC 388-825-564 Does my family have a choice of FSP services?** The individual and family identify and choose FSP services per WAC 388-825-558 through the department's assessment and planning process. Adult clients are included in the choice of FSP services.

#### NEW SECTION

**WAC 388-825-572 What if I have needs that exceed my FSP award limit?** If you have needs that exceed your FSP award limit, DDD may approve additional funding to meet certain extraordinary needs as "one-time award". This approval is an exception to your award limit and you cannot appeal the amount of the exception or denial of an exception.

#### NEW SECTION

**WAC 388-825-575 What are one-time awards?** A one-time award is limited to extraordinary support for individuals receiving FSP funding.

(1) The one-time award can only be approved for the following services performed by a DDD contracted provider:

- (a) Respite care; and/or
- (b) Behavior management/counseling.

(2) A one-time award may be approved only once during the period of time covered by your FSP plan.

(3) Providers of the services in subsection (1) of this section must be contracted with and paid directly by DDD.

#### NEW SECTION

**WAC 388-825-576 How do I apply for a one-time award?** You may apply for a one-time award by following the procedures contained in WAC 388-825-236.

#### NEW SECTION

**WAC 388-825-578 What amount of one-time funding is available for my family?** The maximum amount of one-time funding available for respite care and/or behavior management/counseling is the same as the amount of your award, determined by WAC 388-825-548.

#### NEW SECTION

**WAC 388-825-581 How long do I remain eligible for the FSP?** (1) If you are approved for an FSP award, your FSP plan will be reviewed annually for continued funding as long as FSP funding is available.

(2) The Family Support Pilot ends June 30, 2007.

#### NEW SECTION

**WAC 388-825-584 Can I be terminated from FSP?** You will be terminated from FSP if any of the following occur:

(1) Your DDD eligibility is terminated per chapter 388-823 WAC;

(2) You no longer live with a family as defined in WAC 388-825-512;

(3) You begin living independently or with a spouse;

(4) You begin to receive other DDD funded services;

(5) Your household income exceeds 400% of the FPL;

(6) You become eligible for Medicaid Personal Care;

and or

(7) FSP funding is no longer available.

#### NEW SECTION

**WAC 388-825-586 When are changes in my circumstances considered effective?** (1) Except for changes in income and/or household size, changes are effective immediately.

(2) Changes in gross annual household income and changes in household size are effective at the time your FSP plan is reviewed.

#### NEW SECTION

**WAC 388-825-588 How will the department notify me of their decisions?** The department will provide written notification to you and your legal representative of all eligibility and service decisions per WAC 388-825-100 through WAC 388-825-105. These notices will include your appeal rights.

NEW SECTION

**WAC 388-825-591 What are my appeal rights under the FSP?** You have appeal rights under WAC 388-825-120 to the following decisions:

- (1) Denial of eligibility to participate in the FSP per WAC 388-825-510.
- (2) A denial, reduction or termination of FSP services.
- (3) A denial or termination of your choice of a qualified provider.

NEW SECTION

**WAC 388-825-595 How do I appeal a department action?** Your appeal rights and procedures to appeal a department decision are in WAC 388-825-120 through WAC 388-825-165.

**WSR 05-24-094**  
**PROPOSED RULES**  
**DEPARTMENT OF**  
**FISH AND WILDLIFE**  
 [Filed December 7, 2005, 8:18 a.m.]

Original Notice.

Preproposal statement of inquiry was filed as WSR 05-20-112.

Title of Rule and Other Identifying Information: WAC 232-28-294 Multiple season big game permits, 232-28-295 Landowner hunting permits, 232-28-293 PLWMA raffle hunts, 232-28-271 PLWMA rules and boundary.

Hearing Location(s): Natural Resources Building, 1111 Washington Street S.E., Olympia, WA 98504, on January 13-14, 2006, at 8:00 a.m.

Date of Intended Adoption: January 13, 2006.

Submit Written Comments to: Attn: Wildlife Program Commission Meeting Public Comments, 600 Capitol Way North, Olympia, WA 98501-1091, e-mail Wildthing@dfw.wa.gov, fax (360) 902-2612, by Wednesday, December 28, 2005.

Assistance for Persons with Disabilities: Contact Susan Yeager by November [December] 30, 2005, TTY (360) 902-2207 or (360) 902-2267.

Purpose of the Proposal and Its Anticipated Effects, Including Any Changes in Existing Rules: WAC 232-28-294, this proposal establishes a new rule to allow permit hunters to hunt deer or elk during more than one general season.

WAC 232-28-295, this proposal establishes landowner hunting permits and encourages hunter access to private lands under contract with the department.

WAC 232-28-293, the proposal is to amend this rule to make it consistent with recent adoption of commission policy on private lands; termination of private lands wildlife management area (PLWMA) program; and allows second licenses authorized by this rule to be purchased where ever feasible.

WAC 232-28-271, the proposal is to delete an obsolete rule.

Reasons Supporting Proposal: WAC 232-28-294, this rule provides greater season length and hunting opportunity to a randomly drawn group of hunters. The number of participants is limited by permit drawing to ensure controls over harvest levels.

WAC 232-28-295, this rule provides incentives to private landowners to open their property for hunter access.

WAC 232-28-293, this proposal clarifies that raffle hunts may be conducted by private landowners and eliminates references to PLWMAs.

WAC 232-28-271, this rule is no longer necessary and the applicable dates have expired.

Statutory Authority for Adoption: RCW 77.12.047.

Statute Being Implemented: RCW 77.12.047.

Rule is not necessitated by federal law, federal or state court decision.

Name of Proponent: Washington Fish and Wildlife Commission, governmental.

Name of Agency Personnel Responsible for Drafting and Implementation: Dave Brittell, Natural Resources Building, Olympia, (360) 902-2504; and Enforcement: Bruce Bjork, Natural Resources Building, Olympia, (360) 902-2932.

A small business economic impact statement has been prepared under chapter 19.85 RCW.

Small Business Economic Impact Statement

For WAC 232-28-293 PLWMA Raffle Hunts

1. Description of the Reporting, Record-keeping, and Other Compliance Requirements of the Proposed Rule: None beyond what is already required by existing Washington State Gambling Commission rules.

2. Kinds of Professional Services That a Small Business is Likely to Need in Order to Comply with Such Requirements: None.

3. Costs of Compliance for Businesses, Including Costs of Equipment, Supplies, Labor, and Increased Administrative Costs: None.

4. Will Compliance with the Rule Cause Businesses to Lose Sales or Revenue? No.

5. Cost of Compliance for the 10% of Businesses That are the Largest Businesses Required to Comply with the Proposed Rules Using One or More of the Following as a Basis for Comparing Costs: Cost per employee, cost per hour of labor, or cost per one hundred dollars of sales: No costs for compliance with this rule are identified.

6. Steps Taken by the Agency to Reduce the Costs of the Rule on Small Businesses or Reasonable Justification for Not Doing So: None were needed.

7. A Description of How the Agency Will Involve Small Businesses in the Development of the Rule: WDFW held several stakeholders meetings with selected individuals that represented interests from various landowners who could be impacted by the rule (e.g., industrial timberland and Washington State Grange).

8. A List of Industries That Will Be Required to Comply with the Rule: Persons who elect to sign an access contract with WDFW and who agree to meet contract provisions will be required to comply with the rule.

A copy of the statement may be obtained by contacting Wildlife Program, 600 Capitol Way North, Olympia, WA 98501-1091, phone (360) 902-2515, fax (360) 902-2162, e-mail Wildthing@dfw.wa.gov.

No small business economic impact statement has been prepared under chapter 19.85 RCW for WAC 232-28-294 Multiple season big game permits, 232-28-295 Landowner hunting permits, and 232-28-271 PLWMA rules and boundary, regulate recreational hunters and do not directly regulate small business.

A cost-benefit analysis is not required under RCW 34.05.328. Not hydraulics rules.

December 6, 2005  
 Evan Jacoby  
 Rules Coordinator

A. To apply for multiple season big game hunting season permits for deer or elk, applicants must purchase and submit a permit application.

B. No refunds or exchanges for applications will be made for persons applying for multiple season big game hunting season permits after the drawing has been held.

C. An applicant may purchase only one application for a multiple season big game hunting season permit for each species.

D. Permits will be randomly drawn by computer selection.

E. Incomplete applications will not be accepted.

F. The department will establish application and drawing dates.

2) The bag limit for this permit is one deer or elk.

3) Multiple season permits:

A. Hunters who are drawn will be required to purchase their original deer or elk license, corresponding to their permit, and the multiple season big game permit.

B. Successful applicants must purchase their multiple season permit within 30 days of the drawing notification date. If they have not purchased the multiple season permit by the deadline, the next person drawn will be offered the permit.

C. The permits are not transferable.

NEW SECTION

**WAC 232-28-294 Multiple season big game permits.**

The Commission may, by rule, offer permits for hunters to hunt deer or elk during more than one general season. An annual drawing will be conducted by the department for multiple season permits.

1) Multiple season big game hunting permit applications:

Number of Permits	Dates	Game Management Units (GMUs)	Legal Animal
<b>Multiple Season Deer Permits</b>			
1500	Sept. 1 - December 31 within established general seasons for deer by the Commission	Statewide in those GMUs with general seasons for archery, muzzleloader, or modern firearm hunters	Any buck
<b>Multiple Season Elk Permits</b>			
500	Sept. 1 - December 31 within established general seasons for elk by the Commission	Statewide in those GMUs with general seasons for archery, muzzleloader, or modern firearm hunters	Any bull

NEW SECTION

**WAC 232-28-295 Landowner hunting permits.** A landowner may enter into a contract with the department and establish boundaries and other requirements for hunter access consistent with Commission policy.

Hunters must possess both an access permit from the landowner and a hunting permit from the department when hunting on lands and for species covered under contract.

**Buckrun:**

**Mule and Whitetail Deer**

**Buckrun Landowner Hunting Permits**

The manager of Buckrun will distribute these hunting permits. An access fee may be charged in order to utilize these permits. Only hunters possessing a modern firearm deer tag are eligible for permits on Buckrun properties. You may contact the manager, Derek Stevens, at (509) 345-2577 for information.

Hunt Name	Quota	Access Season	Special Restrictions	Boundary Description
Buckrun	12	Sept. 15 - Dec. 31	Any Deer	Lands identified in WDFW's contract with Buckrun.
	50	Sept. 15 - Nov. 5	*3 Pt. Maximum or Antlerless deer	Lands identified in WDFW's contract with Buckrun.
	40	Sept. 15 - Dec. 31	Antlerless Only	Lands identified in WDFW's contract with Buckrun.
Buckrun Raffle	3	Sept. 15 - Dec. 31	Raffle - Any Deer	Lands identified in WDFW's contract with Buckrun.

## Mule and Whitetail Deer

### Buckrun Special Hunting Permits

Hunters apply to Washington Department of Fish and Wildlife for these permits. Only hunters possessing a modern firearm deer tag are eligible for Buckrun special hunting permits. Hunters can expect one to three days of hunting during the permit season with a written access permit from the Buckrun manager. All hunters must check in and out with Buckrun manager on hunt day.

Hunt Name	Permit Number	Permit Season	Special Restrictions	Boundary Description
Buckrun A	5	Sept. 1 - Dec. 31	Any Deer	Lands identified in WDFW's contract with Buckrun.
Buckrun B	20	Sept. 1 - Nov. 5	*3 Pt. Maximum or Antlerless deer	Lands identified in WDFW's contract with Buckrun.
Buckrun C	40	Oct. 24 - Dec. 31	Antlerless deer	Lands identified in WDFW's contract with Buckrun.
Buckrun D	10	Sept. 1 - Dec. 31	Senior hunters only, Antlerless deer	Lands identified in WDFW's contract with Buckrun.

\*3 Pt. maximum - A legal deer must have no more than 3 antler points on either antler (i.e. 1x1, 1x2, 1x3, 2x2, 2x3, 3x3 are legal). All antler points must be at least one inch long. Antler points exclude eye guards. Hunts are scheduled by the manager 509-345-2577. All other hunting regulations apply.

AMENDATORY SECTION (Amending Order 01-69, filed 4/26/01, effective 5/27/01)

**WAC 232-28-293 ((PLWMA)) Landowner raffle hunts.** The commission, in consultation with the director and by agreement with ((a)) cooperating private ((lands wildlife management area (PLWMA))) landowners, may authorize hunts for big game animals through raffle.

1. The ((PLWMA)) manager of property under contract with WDFW will conduct the landowner raffle drawing. Raffle tickets will be sold for not more than \$25.00 each.

2. Any person may purchase ((PLWMA)) landowner raffle tickets in addition to WDFW raffle tickets and participate in auctions and special hunting season permit drawings.

3. The ((PLWMA)) landowner raffle winners must possess the appropriate hunting license and transport tag prior to participating in the ((PLWMA)) landowner raffle hunt.

4. The ((PLWMA)) landowner deer or elk raffle hunt winners may purchase an additional deer or elk hunting license and obtain a second transport tag if desired.

5. If an additional deer or elk hunting license and transport tag are acquired by a raffle winner, the additional transport tag can only be used on the ((PLWMA)) contracted lands during the raffle hunt.

~~((6. The additional deer or elk hunting license and transport tag must be issued by the Olympia department headquarters licensing division.))~~

7) 6. Hunting licenses or transport tags obtained pursuant to a raffle may not be resold or reassigned.

((8)) 7. The ((PLWMA)) manager of property under contract with WDFW who is conducting an authorized raffle will provide an annual report to the department of fish and wildlife prior to December 31. The report will include information on how the event was administered, where and when it occurred, who the winners were, the cost of tickets, and the number of tickets sold.

((9)) 8. Anyone may participate in ((PLWMA)) landowner raffles.

**Reviser's note:** The typographical error in the above section occurred in the copy filed by the agency and appears in the Register pursuant to the requirements of RCW 34.08.040.

### REPEALER

The following section of the Washington Administrative Code is repealed:

WAC 232-28-271

Private lands wildlife management area hunting seasons, rules and boundary descriptions.

## WSR 05-24-115

### PROPOSED RULES

### DEPARTMENT OF HEALTH

[Filed December 7, 2005, 9:28 a.m.]

Supplemental Notice to WSR 05-19-053.

Exempt from preproposal statement of inquiry under RCW 34.05.310(4).

Title of Rule and Other Identifying Information: Medical use of radioactive material, chapter 246-240 WAC (sections are being added, amended and repealed). Sections of other chapters in the radiation protection regulations are being changed to bring them into conformity with the US Nuclear Regulatory Commission (USNRC) rules for medical use of radioactive material. In addition to those sections in chapter 246-240 WAC, the following sections of existing regulations are amended or repealed: WAC 246-220-010, 246-221-001, 246-221-060, 246-221-130; 246-232-001, 246-232-014, 246-235-020, 246-235-080, 246-235-090, 246-235-100, 246-235-102, 246-235-110, 246-235-120 Schedule A (repealed), 246-239-001, 246-239-010, 246-239-020, 246-239-022, 246-239-025, 246-239-030, 246-239-035, 246-239-040, 246-239-050, 246-239-055, 246-239-060, 246-239-070, 246-239-080, 246-239-090, and 246-239-100 (all repealed).

Hearing Location(s): Washington State Department of Health, Town Center 2, Room 145, 111 Israel Road S.E., Tumwater, WA 98501, on January 10, 2006, at 10:00 a.m.

Date of Intended Adoption: January 12, 2006.

Submit Written Comments to: Arden C. Scroggs, P.O. Box 47827, Olympia, WA 98504, e-mail <http://www3.doh.wa.gov/policyreview/>, fax (360) 236-2255, by January 10, 2005 [2006].

Assistance for Persons with Disabilities: Contact Arden C. Scroggs by January 3, 2006, TTY (800) 838-6388.

Purpose of the Proposal and Its Anticipated Effects, Including Any Changes in Existing Rules: A hearing was held on October 28, 2005. Changes have been made to the original text based on comments received at the hearing and from the Nuclear Regulatory Commission. The changes incorporate portions of the federal rule that were inadvertently omitted from the proposal as well as several other changes made for clarity and consistency with other rules.

In response to comments received at the public hearing, in writing, and from the USNRC, the following changes have been made:

A. WAC 246-220-010, the definition of "physician" was changed to clearly include doctors of osteopathy as well as medical doctors;

B. WAC 246-240-001 Purpose and scope, now includes the sentence formerly contained in 10 C.F.R. 35.10(e), and inadvertently omitted in the original proposal, i.e. "When a requirement in this chapter differs from the requirement in an existing license condition, the requirement in this chapter shall govern";

C. The inadvertently omitted word "verifies" was added to the definition of preceptor in WAC 246-240-010 as required by 10 C.F.R. 35.2;

D. Inadvertently omitted references to certain written requirements for an authorized medical physicist to perform certification functions have been added to WAC 246-240-072 as required by 10 C.F.R. 35.51;

E. The number of required training hours referenced in WAC 246-240-075 as seven hundred hours has been changed to reflect the two hundred hours currently required by 10 C.F.R. 35.55;

F. Inadvertently omitted references to certain written requirements for an authorized nuclear pharmacist to perform certification functions have been added to WAC 246-240-075 as required by 10 C.F.R. 35.55;

G. The minimum requirement of eight hours classroom and laboratory training, inadvertently omitted from WAC 246-240-154, has been added as required by 10 C.F.R. 35.190;

H. The minimum requirement of eighty hours of classroom and laboratory training, inadvertently omitted from WAC 246-240-163, has been added as required by 10 C.F.R. 35.290;

I. WAC 246-240-210 as proposed requires a minimum three year residency training period while the USNRC rule does not specify a minimum training period. The minimum training period of three years has been deleted as required by 10 C.F.R. 35.390;

J. WAC 246-240-210 does not include the minimum two hundred hours of classroom and laboratory training require-

ment. The two hundred hour training requirement has been added as required by 10 C.F.R. 35.390; and

K. Training for the parenteral administration of unsealed radioactive material requiring a written directive was inadvertently omitted. This new section, WAC 246-240-219, has been added as required by 10 C.F.R. 35.396.

Reasons Supporting Proposal: Uniformity of regulations is intended to promote ease of use, and thus greater conformity, with regulations governing licensees who use radioactive material for medical purposes.

Statutory Authority for Adoption: RCW 70.98.050.

Statute Being Implemented: RCW 70.98.050.

Rule is necessary because of federal law, 67 F.R. 20250, 10 C.F.R. 35, 70 F.R. 16336.

Name of Proponent: Department of Health, governmental.

Name of Agency Personnel Responsible for Drafting: C. DeMaris, 111 Israel Road S.W., Tumwater, WA, (360) 236-3223; Implementation and Enforcement: A. Scroggs, 111 Israel Road S.W., Tumwater, WA, (360) 236-3221.

No small business economic impact statement has been prepared under chapter 19.85 RCW. This rule change is exempt from the small business impact statement requirement under RCW 19.85.025(3) because it adopts federal regulations without material change. This rule also has a "regulatory flexibility certification" prepared by USNRC stating that the "rule will not have a significant economic impact upon a substantial number of small entities."

A cost-benefit analysis is not required under RCW 34.05.328. Under RCW 34.05.328 (5)(b)(iii) and (iv), RCW 34.05.328 (1)-(4) do not apply to this rule adoption because this rule adopts federal regulations without material change and clarifies the language of a rule or otherwise makes house-keeping changes. This rule is for conformance with the USNRC regulations and is mandatory under our agreement state status with the federal government.

December 5, 2005

Mary C. Selecky  
Secretary

AMENDATORY SECTION (Amending WSR 04-23-093, filed 11/17/04, effective 12/18/04)

**WAC 246-220-010 Definitions.** As used in these regulations, these terms have the definitions set forth below. Additional definitions used only in a certain part will be found in that part.

(1) "Absorbed dose" means the energy imparted by ionizing radiation per unit mass of irradiated material. The units of absorbed dose are the gray (Gy) and the rad.

(2) "Accelerator produced material" means any material made radioactive by exposing it in a particle accelerator.

(3) "Act" means Nuclear energy and radiation, chapter 70.98 RCW.

(4) "Activity" means the rate of disintegration or transformation or decay of radioactive material. The units of activity are the becquerel (Bq) and the curie (Ci).

(5) "Adult" means an individual eighteen or more years of age.



(6) "Agreement state" means any state with which the United States Nuclear Regulatory Commission has entered into an effective agreement under section 274 b. of the Atomic Energy Act of 1954, as amended (73 Stat. 689).

(7) "Airborne radioactive material" means any radioactive material dispersed in the air in the form of particulates, dusts, fumes, mists, vapors, or gases.

(8) "Airborne radioactivity area" means a room, enclosure, or operating area in which airborne radioactive material exists in concentrations (a) in excess of the derived air concentration (DAC) specified in WAC 246-221-290, Appendix A, or (b) to ~~((such a))~~ the degree that an individual present in the area without respiratory protective equipment could exceed, during the hours an individual is present in a week, an intake of 0.6 percent of the annual limit on intake (ALI) or twelve DAC-hours.

(9) "Air purifying respirator" means a respirator with an air-purifying filter, cartridge, or canister that removes specific air contaminants by passing ambient air through the air-purifying element.

(10) "Alert" means events may occur, are in progress, or have occurred that could lead to a release of radioactive material but that the release is not expected to require a response by offsite response organizations to protect persons offsite.

(11) "Annual limit on intake" (ALI) means the derived limit for the amount of radioactive material taken into the body of an adult worker by inhalation or ingestion in a year. ALI is the smaller value of intake of a given radionuclide in a year by the reference man that would result in a committed effective dose equivalent of 0.05 Sv (5 rem) or a committed dose equivalent of 0.5 Sv (50 rem) to any individual organ or tissue. ALI values for intake by ingestion and by inhalation of selected radionuclides are given in WAC 246-221-290.

(12) "Assigned protection factor" (APF) means the expected workplace level of respiratory protection that would be provided by a properly functioning respirator or a class of respirators to properly fitted and trained users. Operationally, the inhaled concentration can be estimated by dividing the ambient airborne concentration by the APF.

(13) "Atmosphere-supplying respirator" means a respirator that supplies the respirator user with breathing air from a source independent of the ambient atmosphere, and includes supplied-air respirators (SARs) and self-contained breathing apparatus (SCBA) units.

(14) "Background radiation" means radiation from cosmic sources; naturally occurring radioactive materials, including radon, except as a decay product of source or special nuclear material, and including global fallout as it exists in the environment from the testing of nuclear explosive devices or from past nuclear accidents such as Chernobyl that contribute to background radiation and are not under the control of the licensee. "Background radiation" does not include sources of radiation from radioactive materials regulated by the department.

(15) "Becquerel" (Bq) means the SI unit of activity. One becquerel is equal to 1 disintegration or transformation per second ( $s^{-1}$ ).

(16) "Bioassay" means the determination of kinds, quantities or concentrations, and, in some cases, the locations of radioactive material in the human body, whether by direct

measurement, in vivo counting, or by analysis and evaluation of materials excreted or removed from the human body. For purposes of these regulations, "radiobioassay" is an equivalent term.

(17) "Byproduct material" means: (a) Any radioactive material (except special nuclear material) yielded in or made radioactive by exposure to the radiation incident to the process of producing or utilizing special nuclear material, and (b) the tailings or wastes produced by the extraction or concentration of uranium or thorium from any ore processed primarily for its source material content, including discrete surface wastes resulting from uranium or thorium solution extraction processes. Underground ore bodies depleted by these solution extraction operations do not constitute "byproduct material" within this definition.

(18) "Calendar quarter" means ~~((not less than))~~ at least twelve ~~((consecutive weeks nor))~~ but no more than fourteen consecutive weeks. The first calendar quarter of each year ~~((shall))~~ begins in January and subsequent calendar quarters shall be ~~((so))~~ arranged ~~((such))~~ so that no day is included in more than one calendar quarter and no day in any one year is omitted from inclusion within a calendar quarter. ~~((No))~~ A licensee or registrant ~~((shall))~~ may not change the method of determining calendar quarters for purposes of these regulations ~~((except at the beginning of a calendar year))~~.

(19) "Calibration" means the determination of (a) the response or reading of an instrument relative to a series of known radiation values over the range of the instrument, or (b) the strength of a source of radiation relative to a standard.

(20) "CFR" means Code of Federal Regulations.

(21) "Class" means a classification scheme for inhaled material according to its rate of clearance from the pulmonary region of the lung. Materials are classified as D, W, or Y, which applies to a range of clearance half-times: For Class D, Days, of less than ten days, for Class W, Weeks, from ten to one hundred days, and for Class Y, Years, of greater than one hundred days. For purposes of these regulations, "lung class" and "inhalation class" are equivalent terms. For "class of waste" see WAC 246-249-040.

(22) "Collective dose" means the sum of the individual doses received in a given period of time by a specified population from exposure to a specified source of radiation.

(23) "Committed dose equivalent" ( $H_{T,50}$ ) means the dose equivalent to organs or tissues of reference (T) that will be received from an intake of radioactive material by an individual during the fifty-year period following the intake.

(24) "Committed effective dose equivalent" ( $H_{E,50}$ ) is the sum of the products of the weighting factors applicable to each of the body organs or tissues that are irradiated and the committed dose equivalent to each of these organs or tissues ( $H_{E,50} = ((S)) \&S_{gr}; w_T, H_{T,50}$ ).

(25) "Constraint" or dose constraint means a value above which specified licensee actions are required.

(26) "Controlled area." See "Restricted area."

(27) "Curie" means a unit of quantity of radioactivity. One curie (Ci) is that quantity of radioactive material which decays at the rate of  $3.7 \times 10^{10}$  transformations per second (tps).

(28) "Declared pregnant woman" means a woman who has voluntarily informed the licensee or registrant, in writing,

of her pregnancy, and the estimated date of conception. The declaration remains in effect until the declared pregnant woman withdraws the declaration in writing or is no longer pregnant.

(29) "Deep dose equivalent" ( $H_d$ ), which applies to external whole body exposure, means the dose equivalent at a tissue depth of 1 centimeter ( $1000 \text{ mg/cm}^2$ ).

(30) "Demand respirator" means an atmosphere-supplying respirator that admits breathing air to the facepiece only when a negative pressure is created inside the facepiece by inhalation.

(31) "Department" means the Washington state department of health, (~~(division)~~) office of radiation protection, which has been designated as the state radiation control agency under chapter 70.98 RCW.

(32) "Depleted uranium" means the source material uranium in which the isotope Uranium-235 is less than 0.711 percent by weight of the total uranium present. Depleted uranium does not include special nuclear material.

(33) "Derived air concentration" (DAC) means the concentration of a given radionuclide in air which, if breathed by the reference man for a working year of two thousand hours under conditions of light work, results in an intake of one ALI. For purposes of these regulations, the condition of light work is an inhalation rate of 1.2 cubic meters of air per hour for two thousand hours in a year. DAC values are given in WAC 246-221-290.

(34) "Derived air concentration-hour" (DAC-hour) means the product of the concentration of radioactive material in air, expressed as a fraction or multiple of the derived air concentration for each radionuclide, and the time of exposure to that radionuclide, in hours. A licensee or registrant may take two thousand DAC-hours to represent one ALI, equivalent to a committed effective dose equivalent of 0.05 Sv (5 rem).

(35) "Disposable respirator" means a respirator for which maintenance is not intended and that is designed to be discarded after excessive breathing resistance, sorbent exhaustion, physical damage, or end-of-service-life renders it unsuitable for use. Examples of this type of respirator are a disposable half-mask respirator or a disposable escape-only self-contained breathing apparatus (SCBA).

(36) "Dose" is a generic term that means absorbed dose, dose equivalent, effective dose equivalent, committed dose equivalent, committed effective dose equivalent, total organ dose equivalent, or total effective dose equivalent. For purposes of these (~~(regulations)~~) rules, "radiation dose" is an equivalent term.

(37) "Dose commitment" means the total radiation dose to a part of the body that will result from retention in the body of radioactive material. For purposes of estimating the dose commitment, it is assumed that from the time of intake the period of exposure to retained material will not exceed fifty years.

(38) "Dose equivalent" ( $H_T$ ) means the product of the absorbed dose in tissue, quality factor, and all other necessary modifying factors at the location of interest. The units of dose equivalent are the sievert (Sv) and rem.

(39) "Dose limits" means the permissible upper bounds of radiation doses established in accordance with these regu-

lations. For purposes of these regulations, "limits" is an equivalent term.

(40) "Dosimetry processor" means a person that processes and evaluates individual monitoring devices in order to determine the radiation dose delivered to the monitoring devices.

(41) "dpm" means disintegrations per minute. See also "curie."

(42) "Effective dose equivalent" ( $H_E$ ) means the sum of the products of the dose equivalent to each organ or tissue ( $H_T$ ) and the weighting factor ( $w_T$ ) applicable to each of the body organs or tissues that are irradiated ( $H_E = \sum w_T H_T$ ).

(43) "Embryo/fetus" means the developing human organism from conception until the time of birth.

(44) "Entrance or access point" means any opening through which an individual or extremity of an individual could gain access to radiation areas or to licensed radioactive materials. This includes entry or exit portals of sufficient size to permit human entry, without respect to their intended use.

(45) "Exposure" means (a) being exposed to ionizing radiation or to radioactive material, or (b) the quotient of  $\Delta Q$  by  $\Delta m$  where " $\Delta Q$ " is the absolute value of the total charge of the ions of one sign produced in air when all the electrons (negatrons and positrons) liberated by photons in a volume element of air having mass " $\Delta m$ " are completely stopped in air. The special unit of exposure is the roentgen (R) and the SI equivalent is the coulomb per kilogram. One roentgen is equal to  $2.58 \times 10^{-4}$  coulomb per kilogram of air.

(46) "Exposure rate" means the exposure per unit of time, such as roentgen per minute and milliroentgen per hour.

(47) "External dose" means that portion of the dose equivalent received from any source of radiation outside the body.

(48) "Extremity" means hand, elbow, arm below the elbow, foot, knee, and leg below the knee.

(49) "Filtering facepiece" (dust mask) means a negative pressure particulate respirator with a filter as an integral part of the facepiece or with the entire facepiece composed of the filtering medium, not equipped with elastomeric sealing surfaces and adjustable straps.

(50) "Fit factor" means a quantitative estimate of the fit of a particular respirator to a specific individual, and typically estimates the ratio of the concentration of a substance in ambient air to its concentration inside the respirator when worn.

(51) "Fit test" means the use of a protocol to qualitatively or quantitatively evaluate the fit of a respirator on an individual.

(52) "Former United States Atomic Energy Commission (AEC) or United States Nuclear Regulatory Commission (NRC) licensed facilities" means nuclear reactors, nuclear fuel reprocessing plants, uranium enrichment plants, or critical mass experimental facilities where AEC or NRC licenses have been terminated.

(53) "Generally applicable environmental radiation standards" means standards issued by the United States Environmental Protection Agency (EPA) under the authority of the Atomic Energy Act of 1954, as amended, that impose limits on radiation exposures or levels, or concentrations or quanti-

ties of radioactive material, in the general environment outside the boundaries of locations under the control of persons possessing or using radioactive material.

(54) "Gray" (Gy) means the SI unit of absorbed dose. One gray is equal to an absorbed dose of 1 joule/kilogram (100 rad).

(55) "Healing arts" means the disciplines of medicine, dentistry, osteopathy, chiropractic, podiatry, and veterinary medicine.

(56) "Helmet" means a rigid respiratory inlet covering that also provides head protection against impact and penetration.

(57) "High radiation area" means any area, accessible to individuals, in which radiation levels from radiation sources external to the body could result in an individual receiving a dose equivalent in excess of 1 mSv (0.1 rem) in one hour at 30 centimeters from any source of radiation or 30 centimeters from any surface that the radiation penetrates. For purposes of these regulations, rooms or areas in which diagnostic X-ray systems are used for healing arts purposes are not considered high radiation areas.

(58) "Hood" means a respiratory inlet covering that completely covers the head and neck and may also cover portions of the shoulders and torso.

(59) "Human use" means the intentional internal or external administration of radiation or radioactive material to human beings.

(60) "Immediate" or "immediately" means as soon as possible but no later than four hours after the initiating condition.

(61) "IND" means investigatory new drug for which an exemption has been claimed under the United States Food, Drug and Cosmetic Act (Title 21 CFR).

(62) "Individual" means any human being.

(63) "Individual monitoring" means the assessment of:

(a) Dose equivalent (i) by the use of individual monitoring devices or (ii) by the use of survey data; or

(b) Committed effective dose equivalent (i) by bioassay or (ii) by determination of the time-weighted air concentrations to which an individual has been exposed, that is, DAC-hours.

(64) "Individual monitoring devices" (individual monitoring equipment) means devices designed to be worn by a single individual for the assessment of dose equivalent ~~((such))~~ e.g. as film badges, thermoluminescent dosimeters (TLDs), pocket ionization chambers, and personal ("lapel") air sampling devices.

(65) "Inspection" means an official examination or observation by the department including but not limited to, tests, surveys, and monitoring to determine compliance with rules, ~~((regulations,))~~ orders, requirements and conditions of the department.

(66) "Interlock" means a device arranged or connected ~~((such))~~ so that the occurrence of an event or condition is required before a second event or condition can occur or continue to occur.

(67) "Internal dose" means that portion of the dose equivalent received from radioactive material taken into the body.

(68) "Irretrievable source" means any sealed source containing licensed material which is pulled off or not connected to the wireline downhole and for which all reasonable effort at recovery, as determined by the department, has been expended.

(69) "Lens dose equivalent" (LDE) applies to the external exposure of the lens of the eye and is taken as the dose equivalent at a tissue depth of 0.3 centimeters (300 mg/cm<sup>2</sup>).

(70) "License" means a license issued by the department ~~((in accordance with the regulations adopted by the department)).~~

(71) "Licensed material" means radioactive material received, possessed, used, transferred, or disposed under a general or specific license issued by the department.

(72) "Licensee" means any person who is licensed by the department ~~((in accordance with))~~ under these ~~((regulations))~~ rules and the act.

(73) "Licensing state" means any state with regulations equivalent to the suggested state regulations for control of radiation relating to, and an effective program for, the regulatory control of NARM and which has been granted final designation by the Conference of Radiation Control Program Directors, Inc.

(74) "Loose-fitting facepiece" means a respiratory inlet covering that is designed to form a partial seal with the face.

(75) "Lost or missing licensed material" means licensed material whose location is unknown. This definition includes licensed material that has been shipped but has not reached its planned destination and whose location cannot be readily traced in the transportation system.

(76) "Member of the public" means an individual except when the individual is receiving an occupational dose.

(77) "Minor" means an individual less than eighteen years of age.

(78) "Monitoring" means the measurement of radiation, radioactive material concentrations, surface area activities or quantities of radioactive material and the use of the results of these measurements to evaluate potential exposures and doses. For purposes of these regulations, radiation monitoring and radiation protection monitoring are equivalent terms.

(79) "NARM" means any naturally occurring or accelerator-produced radioactive material. It does not include by-product, source, or special nuclear material. For the purpose of meeting the definition of a Licensing State by the Conference of Radiation Control Program Directors, Inc. (CRCPD), NARM refers only to discrete sources of NARM. Diffuse sources of NARM are excluded from consideration by the CRCPD for Licensing State designation purposes.

(80) "Natural radioactivity" means radioactivity of naturally occurring nuclides.

(81) "NDA" means a new drug application which has been submitted to the United States Food and Drug Administration.

(82) "Negative pressure respirator" (tight-fitting) means a respirator in which the air pressure inside the facepiece is negative during inhalation with respect to the ambient air pressure outside the respirator.

(83) "Nonstochastic effect" means a health effect, the severity of which varies with the dose and for which a threshold is believed to exist. Radiation-induced cataract formation

is an example of a nonstochastic effect. For purposes of these ((regulations)) rules, a "deterministic effect" is an equivalent term.

(84) "Nuclear Regulatory Commission" (NRC) means the United States Nuclear Regulatory Commission or its duly authorized representatives.

(85) "Occupational dose" means the dose received by an individual in the course of employment in which the individual's assigned duties involve exposure to radiation or to radioactive material from licensed and unlicensed sources of radiation, whether in the possession of the licensee, registrant, or other person. Occupational dose does not include dose received: From background radiation, from any medical administration the individual has received, from exposure to individuals administered radioactive material and released ((pursuant to)) under chapter((s 246-239 and)) 246-240 WAC, from voluntary participation in medical research programs, or as a member of the public.

(86) "Ore refineries" means all processors of a radioactive material ore.

(87) "Particle accelerator" means any machine capable of accelerating electrons, protons, deuterons, or other charged particles in a vacuum and of discharging the resultant particulate or other radiation into a medium at energies usually in excess of 1 MeV.

(88) "Permittee" means a person who has applied for, and received, a valid site use permit for use of the low-level waste disposal facility at Hanford, Washington.

(89) "Person" means any individual, corporation, partnership, firm, association, trust, estate, public or private institution, group, agency, political subdivision of this state, any other state or political subdivision or agency thereof, and any legal successor, representative, agent or agency of the foregoing, but shall not include federal government agencies.

(90) "Personal supervision" means supervision ((such that)) where the supervisor is physically present at the facility and in ((such)) sufficient proximity that contact can be maintained and immediate assistance given as required.

(91) "Personnel monitoring equipment." See individual monitoring devices.

(92) "Pharmacist" means an individual licensed by this state to compound and dispense drugs, and poisons.

(93) "Physician" means ((an individual)) a medical doctor or doctor of osteopathy licensed by this state to prescribe and dispense drugs in the practice of medicine.

(94) "Planned special exposure" means an infrequent exposure to radiation, separate from and in addition to the annual occupational dose limits.

(95) "Positive pressure respirator" means a respirator in which the pressure inside the respiratory inlet covering exceeds the ambient air pressure outside the respirator.

(96) "Powered air-purifying respirator" (PAPR) means an air-purifying respirator that uses a blower to force the ambient air through air-purifying elements to the inlet covering.

(97) "Practitioner" means an individual licensed by the state in the practice of a healing art (i.e., physician, dentist, podiatrist, chiropractor, etc.).

(98) "Pressure demand respirator" means a positive pressure atmosphere-supplying respirator that admits breathing

air to the facepiece when the positive pressure is reduced inside the facepiece by inhalation.

(99) "Public dose" means the dose received by a member of the public from exposure to sources of radiation under the licensee's or registrant's control or to radiation or radioactive material released by the licensee. Public dose does not include occupational dose or doses received from background radiation, from any medical administration the individual has received, from exposure to individuals administered radioactive material and released ((pursuant to)) under chapter((s 246-239 and)) 246-240 WAC, or from voluntary participation in medical research programs.

(100) "Qualified expert" means an individual who has demonstrated to the satisfaction of the department he/she has the knowledge, training, and experience to measure ionizing radiation, to evaluate safety techniques, and to advise regarding radiation protection needs. The department reserves the right to recognize the qualifications of an individual in specific areas of radiation protection.

(101) "Qualitative fit test" (QLFT) means a pass/fail fit test to assess the adequacy of respirator fit that relies on the individual's response to the test agent.

(102) "Quality factor" (Q) means the modifying factor, listed in Tables I and II, that is used to derive dose equivalent from absorbed dose.

TABLE I  
QUALITY FACTORS AND ABSORBED DOSE EQUIVALENCIES

TYPE OF RADIATION	Quality Factor (Q)	Absorbed Dose Equal to A Unit Dose Equivalent <sup>a</sup>
X, gamma, or beta radiation and high-speed electrons	1	1
Alpha particles, multiple-charged particles, fission fragments and heavy particles of unknown charge	20	0.05
Neutrons of unknown energy	10	0.1
High-energy protons	10	0.1

<sup>a</sup> Absorbed dose in rad equal to 1 rem or the absorbed dose in gray equal to 1 Sv.

If it is more convenient to measure the neutron fluence rate rather than to determine the neutron dose equivalent rate in sievert per hour or rem per hour as required for Table I, then 0.01 Sv (1 rem) of neutron radiation of unknown energies may, for purposes of these regulations, be assumed to result from a total fluence of 25 million neutrons per square centimeter incident upon the body. If sufficient information exists to estimate the approximate energy distribution of the neutrons, the licensee or registrant may use the fluence rate per unit dose equivalent or the appropriate Q value from Table II to convert a measured tissue dose in gray or rad to dose equivalent in sievert or rem.

TABLE II

MEAN QUALITY FACTORS, Q, AND FLUENCE PER UNIT DOSE EQUIVALENT FOR MONOENERGETIC NEUTRONS

Neutron Energy (MeV)	Quality Factor <sup>a</sup> (Q)	Fluence per Unit Dose Equivalent <sup>b</sup> (neutrons cm <sup>-2</sup> rem <sup>-1</sup> )	Fluence per Unit Dose Equivalent <sup>b</sup> (neutrons cm <sup>-2</sup> Sv <sup>-1</sup> )
(thermal) 2.5 x 10 <sup>-8</sup>	2	980 x 10 <sup>6</sup>	980 x 10 <sup>8</sup>
1 x 10 <sup>-7</sup>	2	980 x 10 <sup>6</sup>	980 x 10 <sup>8</sup>
1 x 10 <sup>-6</sup>	2	810 x 10 <sup>6</sup>	810 x 10 <sup>8</sup>
1 x 10 <sup>-5</sup>	2	810 x 10 <sup>6</sup>	810 x 10 <sup>8</sup>
1 x 10 <sup>-4</sup>	2	840 x 10 <sup>6</sup>	840 x 10 <sup>8</sup>
1 x 10 <sup>-3</sup>	2	980 x 10 <sup>6</sup>	980 x 10 <sup>8</sup>
1 x 10 <sup>-2</sup>	2.5	1010 x 10 <sup>6</sup>	1010 x 10 <sup>8</sup>
1 x 10 <sup>-1</sup>	7.5	170 x 10 <sup>6</sup>	170 x 10 <sup>8</sup>
5 x 10 <sup>-1</sup>	11	39 x 10 <sup>6</sup>	39 x 10 <sup>8</sup>
1	11	27 x 10 <sup>6</sup>	27 x 10 <sup>8</sup>
2.5	9	29 x 10 <sup>6</sup>	29 x 10 <sup>8</sup>
5	8	23 x 10 <sup>6</sup>	23 x 10 <sup>8</sup>
7	7	24 x 10 <sup>6</sup>	24 x 10 <sup>8</sup>
10	6.5	24 x 10 <sup>6</sup>	24 x 10 <sup>8</sup>
14	7.5	17 x 10 <sup>6</sup>	17 x 10 <sup>8</sup>
20	8	16 x 10 <sup>6</sup>	16 x 10 <sup>8</sup>
40	7	14 x 10 <sup>6</sup>	14 x 10 <sup>8</sup>
60	5.5	16 x 10 <sup>6</sup>	16 x 10 <sup>8</sup>
1 x 10 <sup>2</sup>	4	20 x 10 <sup>6</sup>	20 x 10 <sup>8</sup>
2 x 10 <sup>2</sup>	3.5	19 x 10 <sup>6</sup>	19 x 10 <sup>8</sup>
3 x 10 <sup>2</sup>	3.5	16 x 10 <sup>6</sup>	16 x 10 <sup>8</sup>
4 x 10 <sup>2</sup>	3.5	14 x 10 <sup>6</sup>	14 x 10 <sup>8</sup>

<sup>a</sup> Value of quality factor (Q) at the point where the dose equivalent is maximum in a 30-cm diameter cylinder tissue-equivalent phantom.

<sup>b</sup> Monoenergetic neutrons incident normally on a 30-cm diameter cylinder tissue-equivalent phantom.

(103) "Quantitative fit test" (QNFT) means an assessment of the adequacy of respirator fit by numerically measuring the amount of leakage into the respirator.

(104) "Quarter" means a period of time equal to one-fourth of the year observed by the licensee, approximately thirteen consecutive weeks, providing that the beginning of the first quarter in a year coincides with the starting date of the year and that no day is omitted or duplicated in consecutive quarters.

(105) "Rad" means the special unit of absorbed dose. One rad equals one-hundredth of a joule per kilogram of material; for example, if tissue is the material of interest, then 1 rad equals 100 ergs per gram of tissue. One rad is equal to an absorbed dose of 100 erg/gram or 0.01 joule/kilogram (0.01 gray).

(106) "Radiation" means alpha particles, beta particles, gamma rays, X rays, neutrons, high-speed electrons, high-speed protons, and other particles capable of producing ions. For purposes of these regulations, ionizing radiation is an equivalent term. Radiation, as used in these regulations, does not include magnetic fields or nonionizing radiation, (~~such as~~) like radiowaves or microwaves, visible, infrared, or ultraviolet light.

(107) "Radiation area" means any area, accessible to individuals, in which radiation levels could result in an individual receiving a dose equivalent in excess of 0.05 mSv (0.005 rem) in one hour at thirty centimeters from the source of radiation or from any surface that the radiation penetrates.

(108) "Radiation machine" means any device capable of producing ionizing radiation except those devices with radioactive materials as the only source of radiation.

(109) "Radiation safety officer" means an individual who has the knowledge and responsibility to apply appropriate radiation protection regulations and has been assigned (~~such~~) that responsibility by the licensee or registrant.

(110) "Radiation source." See "Source of radiation."

(111) "Radioactive material" means any material (solid, liquid, or gas) which emits radiation spontaneously.

(112) "Radioactive waste" means any radioactive material which is no longer of use and intended for disposal or treatment for the purposes of disposal.

(113) "Radioactivity" means the transformation of unstable atomic nuclei by the emission of radiation.

(114) "Reference man" means a hypothetical aggregation of human physical and physiological characteristics determined by international consensus. These characteristics may be used by researchers and public health workers to standardize results of experiments and to relate biological insult to a common base.

(115) "Registrable item" means any radiation machine except those exempted by RCW 70.98.180 or exempted by the department (~~pursuant to~~) under the authority of RCW 70.98.080.

(116) "Registrant" means any person who is registered by the department or is legally obligated to register with the department in accordance with these (~~regulations~~) rules and the act.

(117) "Registration" means registration with the department in accordance with the regulations adopted by the department.

(118) "Regulations of the United States Department of Transportation" means the regulations in 49 CFR Parts 170-189, 14 CFR Part 103, and 46 CFR Part 146.

(119) "Rem" means the special unit of any of the quantities expressed as dose equivalent. The dose equivalent in rem is equal to the absorbed dose in rad multiplied by the quality factor (1 rem = 0.01 Sv).

(120) "Research and development" means: (a) Theoretical analysis, exploration, or experimentation; or (b) the extension of investigative findings and theories of a scientific or technical nature into practical application for experimental and demonstration purposes, including the experimental production and testing of models, devices, equipment, materials, and processes. Research and development does not include the internal or external administration of radiation or radioactive material to human beings.

(121) "Respiratory protective equipment" means an apparatus, such as a respirator, used to reduce an individual's intake of airborne radioactive materials.

(122) "Restricted area" means any area to which access is limited by the licensee or registrant for purposes of protecting individuals against undue risks from exposure to radiation and radioactive material. "Restricted area" (~~shall~~) does

not include any areas used for residential quarters, although a separate room or rooms in a residential building may be set apart as a restricted area.

(123) "Roentgen" (R) means the special unit of exposure. One roentgen equals  $2.58 \times 10^{-4}$  coulombs/kilogram of air.

(124) "Sanitary sewerage" means a system of public sewers for carrying off waste water and refuse, but excluding sewage treatment facilities, septic tanks, and leach fields owned or operated by the licensee or registrant.

(125) "Sealed source" means any radioactive material that is encased in a capsule designed to prevent leakage or the escape of the radioactive material.

(126) "Self-contained breathing apparatus" (SCBA) means an atmosphere-supplying respirator for which the breathing air source is designed to be carried by the user.

(127) "Shallow dose equivalent" (H<sub>s</sub>), which applies to the external exposure of the skin of the whole body or the skin of an extremity, means the dose equivalent at a tissue depth of 0.007 centimeter (7 mg/cm<sup>2</sup>).

(128) "SI" means an abbreviation of the International System of Units.

(129) "Sievert" means the SI unit of any of the quantities expressed as dose equivalent. The dose equivalent in sievert is equal to the absorbed dose in gray multiplied by the quality factor (1 Sv = 100 rem).

(130) "Site area emergency" means events may occur, are in progress, or have occurred that could lead to a significant release of radioactive material and that could require a response by offsite response organizations to protect persons offsite.

(131) "Site boundary" means that line beyond which the land or property is not owned, leased, or otherwise controlled by the licensee or registrant.

(132) "Source container" means a device in which radioactive material is transported or stored.

(133) "Source material" means: (a) Uranium or thorium, or any combination thereof, in any physical or chemical form, or (b) ores which contain by weight one-twentieth of one percent (0.05 percent) or more of (i) uranium, (ii) thorium, or (iii) any combination thereof. Source material does not include special nuclear material.

(134) "Source material milling" means the extraction or concentration of uranium or thorium from any ore processing primarily for its source material content.

(135) "Source of radiation" means any radioactive material, or any device or equipment emitting or capable of producing ionizing radiation.

(136) "Special nuclear material" means:

(a) Plutonium, uranium-233, uranium enriched in the isotope 233 or in the isotope 235, and any other material that the United States Nuclear Regulatory Commission, (~~in accordance with~~) under the provisions of section 51 of the Atomic Energy Act of 1954, as amended, determines to be special nuclear material, but does not include source material; or

(b) Any material artificially enriched in any of the foregoing, but does not include source material.

(137) "Special nuclear material in quantities not sufficient to form a critical mass" means uranium enriched in the isotope U-235 in quantities not exceeding three hundred fifty

grams of contained U-235; Uranium-233 in quantities not exceeding two hundred grams; Plutonium in quantities not exceeding two hundred grams; or any combination of them in accordance with the following formula: For each kind of special nuclear material, determine the ratio between the quantity of that special nuclear material and the quantity specified above for the same kind of special nuclear material. The sum of ~~the~~ the ratios for all of the kinds of special nuclear material in combination shall not exceed "1" (i.e., unity). For example, the following quantities in combination would not exceed the limitation and are within the formula:

$$\frac{175 \text{ (grams contained U-235)}}{350} + \frac{50 \text{ (grams U-233)}}{200} + \frac{50 \text{ (grams Pu)}}{200} < 1$$

(138) "Stochastic effect" means a health effect that occurs randomly and for which the probability of the effect occurring, rather than its severity, is assumed to be a linear function of dose without threshold. Hereditary effects and cancer incidence are examples of stochastic effects. For purposes of these regulations, probabilistic effect is an equivalent term.

(139) "Supplied-air respirator" (SAR) or "airline respirator" means an atmosphere-supplying respirator for which the source of breathing air is not designed to be carried by the user.

(140) "Survey" means an evaluation of the radiological conditions and potential hazards incident to the production, use, release, disposal, or presence of sources of radiation. When appropriate, ~~the~~ the evaluation includes, but is not limited to, tests, physical examinations, calculations and measurements of levels of radiation or concentration of radioactive material present.

(141) "Test" means (a) the process of verifying compliance with an applicable regulation, or (b) a method for determining the characteristics or condition of sources of radiation or components thereof.

(142) "These ~~regulations~~ rules" mean all parts of the rules for radiation protection of the state of Washington.

(143) "Tight-fitting facepiece" means a respiratory inlet covering that forms a complete seal with the face.

(144) "Total effective dose equivalent" (TEDE) means the sum of the deep dose equivalent for external exposures and the committed effective dose equivalent for internal exposures.

(145) "Total organ dose equivalent" (TODE) means the sum of the deep dose equivalent and the committed dose equivalent to the organ or tissue receiving the highest dose.

(146) "United States Department of Energy" means the Department of Energy established by Public Law 95-91, August 4, 1977, 91 Stat. 565, 42 U.S.C. 7101 et seq., to the extent that the department exercises functions formerly vested in the United States Atomic Energy Commission, its chairman, members, officers and components and transferred to the United States Energy Research and Development

Administration and to the administrator thereof (~~(pursuant to)~~) under sections 104 (b), (c) and (d) of the Energy Reorganization Act of 1974 (Public Law 93-438, October 11, 1974, 88 Stat. 1233 at 1237, 42 U.S.C. 5814 effective January 19, 1975) and retransferred to the Secretary of Energy (~~(pursuant to)~~) under section 301(a) of the Department of Energy Organization Act (Public Law 95-91, August 4, 1977, 91 Stat. 565 at 577-578, 42 U.S.C. 7151, effective October 1, 1977).

(147) "Unrefined and unprocessed ore" means ore in its natural form prior to any processing, such as grinding, roasting, beneficiating, or refining.

(148) "Unrestricted area" (uncontrolled area) means any area which is not a restricted area. Areas where the external dose exceeds 2 mrem in any one hour or where the public dose, taking into account occupancy factors, will exceed 100 mrem total effective dose equivalent in any one year must be restricted.

(149) "User seal check" (fit check) means an action conducted by the respirator user to determine if the respirator is properly seated to the face. Examples include negative pressure check, positive pressure check, irritant smoke check, or isoamyl acetate check.

(150) "Very high radiation area" means an area, accessible to individuals, in which radiation levels from radiation sources external to the body could result in an individual receiving an absorbed dose in excess of 5 Gy (500 rad) in one hour at one meter from a source of radiation or one meter from any surface that the radiation penetrates.

(151) "Waste handling licensees" mean persons licensed to receive and store radioactive wastes prior to disposal and/or persons licensed to dispose of radioactive waste.

(152) "Week" means seven consecutive days starting on Sunday.

(153) "Weighting factor"  $w_T$  for an organ or tissue (T) means the proportion of the risk of stochastic effects resulting from irradiation of that organ or tissue to the total risk of stochastic effects when the whole body is irradiated uniformly. For calculating the effective dose equivalent, the values of  $w_T$  are:

ORGAN DOSE WEIGHTING FACTORS

Organ or Tissue	$w_T$
Gonads	0.25
Breast	0.15
Red bone marrow	0.12
Lung	0.12
Thyroid	0.03
Bone surfaces	0.03
Remainder	0.30 <sup>a</sup>
Whole Body	1.00 <sup>b</sup>

<sup>a</sup> 0.30 results from 0.06 for each of 5 "remainder" organs, excluding the skin and the lens of the eye, that receive the highest doses.

<sup>b</sup> For the purpose of weighting the external whole body dose, for adding it to the internal dose, a single weighting factor,  $w_T=1.0$ , has been specified. The use of other weighting factors for external exposure will be approved on a case-by-case basis until such time as specific guidance is issued.

(154) "Whole body" means, for purposes of external exposure, head, trunk including male gonads, arms above the elbow, or legs above the knee.

(155) "Worker" means an individual engaged in activities under a license or registration issued by the department and controlled by a licensee or registrant but does not include the licensee or registrant. Where the licensee or registrant is an individual rather than one of the other legal entities defined under "person," the radiation exposure limits for the worker also apply to the individual who is the licensee or registrant. If students of age eighteen years or older are subjected routinely to work involving radiation, then the students are considered to be workers. Individuals of less than eighteen years of age shall meet the requirements of WAC 246-221-050.

(156) "Working level" (WL) means any combination of short-lived radon daughters in 1 liter of air that will result in the ultimate emission of  $1.3 \times 10^5$  MeV of potential alpha particle energy. The short-lived radon daughters are — for radon-222: polonium-218, lead-214, bismuth-214, and polonium-214; and for radon-220: polonium-216, lead-212, bismuth-212, and polonium-212.

(157) "Working level month" (WLM) means an exposure to one working level for one hundred seventy hours — two thousand working hours per year divided by twelve months per year is approximately equal to one hundred seventy hours per month.

(158) "Year" means the period of time beginning in January used to determine compliance with the provisions of these regulations. The licensee or registrant may change the starting date of the year used to determine compliance by the licensee or registrant provided that the change is made at the beginning of the year and that no day is omitted or duplicated in consecutive years.

**Chapter 246-240 WAC**

**RADIATION PROTECTION—MEDICAL (~~(THERAPY)~~) USE OF RADIOACTIVE MATERIAL**

AMENDATORY SECTION (Amending Order 121, filed 12/27/90, effective 1/31/91)

**WAC 246-240-001 Purpose and scope.** (~~The provisions of this chapter apply to all licensees who use sealed sources in the healing arts and are in addition to, and not in substitution for, other applicable provisions of these regulations.~~) This chapter contains the requirements and provisions for the medical use of radioactive material and for issuance of specific licenses authorizing the medical use of this material. These requirements and provisions provide for the radiation safety of workers, the general public, patients, and human research subjects. The requirements and provisions of chapters 246-220, 246-221, 246-222, 246-232, 246-235, and 246-254 WAC, apply to applicants and licensees subject to this chapter unless specifically exempted. When a requirement in this chapter differs from the requirement in an existing license condition, the requirement in this chapter shall govern.

NEW SECTION

**WAC 246-240-004 Other federal and state requirements.** Nothing in this chapter relieves the licensee from complying with applicable FDA, or other federal and state requirements governing radioactive drugs or devices.

NEW SECTION

**WAC 246-240-007 Provisions for the protection of human research subjects.** (1) A licensee may conduct research involving human research subjects only if it uses the radioactive materials specified on its license for the uses authorized on its license.

(2) If the research is conducted, funded, supported, or regulated by another federal agency that has implemented the Federal Policy for the Protection of Human Subjects (federal policy), the licensee shall, before conducting research:

(a) Obtain review and approval of the research from an "institutional review board," as defined and described in the federal policy; and

(b) Obtain "informed consent," as defined and described in the federal policy, from the human research subject.

(3) If the research will not be conducted, funded, supported, or regulated by another federal agency that has implemented the federal policy, the licensee shall, before conducting research, apply for and receive a specific amendment to its medical use license. The amendment request must include a written commitment that the licensee will, before conducting research:

(a) Obtain review and approval of the research from an "institutional review board," as defined and described in the federal policy; and

(b) Obtain "informed consent," as defined and described in the federal policy, from the human research subject.

(4) Nothing in this section relieves licensees from complying with the other requirements in this chapter.

AMENDATORY SECTION (Amending WSR 98-13-037, filed 6/8/98, effective 7/9/98)

**WAC 246-240-010 Definitions.** ((As used in this chapter, the following definitions apply:

(1) "Authorized user" means a physician who is identified as an authorized user on a department, U.S. Nuclear Regulatory Commission or agreement state license that authorizes the medical use of radioactive material.

(2) "Brachytherapy" means a method of radiation therapy in which sealed sources are utilized to deliver a radiation dose at a distance of up to a few centimeters, by surface, intracavitary, or interstitial application.

(3) "Medical use" means the intentional internal or external administration of radioactive material or the radiation therefrom to patients or human research subjects under the supervision of an authorized user.

(4) "Prescribed dose" means:

(a) For gamma stereotactic radiosurgery, the total dose as documented in the written directive;

(b) For teletherapy, the total dose and dose per fraction as documented in the written directive; or

(c) For brachytherapy, either the total source strength and exposure time, or the total dose, as documented in the written directive.

(5) "Recordable therapy event" means the administration of:

(a) Radiation without a written directive where a written directive is required;

(b) Radiation where a written directive is required without daily recording of each radiation dose in the appropriate record;

(c) A teletherapy radiation dose when the calculated weekly administered dose exceeds the weekly prescribed dose by fifteen percent or more of the weekly prescribed dose; or

(d) A brachytherapy radiation dose when the calculated administered dose differs from the prescribed dose by more than ten percent of the prescribed dose.

(6) "Teletherapy" means therapeutic irradiation in which the source of radiation is at a distance from the body.

(7) "Therapy misadministration" means the administration of:

(a) A gamma stereotactic radiosurgery radiation dose:

(i) Involving the wrong individual or wrong treatment site; or

(ii) When the calculated total administered dose differs from the total prescribed dose by more than ten percent of the total prescribed dose;

(b) A teletherapy radiation dose:

(i) Involving the wrong individual, wrong mode of treatment, or wrong treatment site;

(ii) When the treatment consists of three or fewer fractions and the calculated total administered dose differs from the total prescribed dose by more than ten percent of the total prescribed dose;

(iii) When the calculated weekly administered dose exceeds the weekly prescribed dose by thirty percent or more of the weekly prescribed dose; or

(iv) When the calculated total administered dose differs from the total prescribed dose by more than twenty percent of the total prescribed dose;

(c) A brachytherapy radiation dose:

(i) Involving the wrong individual, wrong radioisotope, or wrong treatment site (excluding, for permanent implants, seeds that were implanted in the correct site but migrated outside the treatment site);

(ii) Involving a sealed source that is leaking;

(iii) When, for a temporary implant, one or more sealed sources are not removed upon completion of the procedure; or

(iv) When the calculated administered dose to the treatment site differs from the prescribed dose by more than twenty percent of the prescribed dose.

(8) "Written directive" means an order in writing for a specific patient or human research subject, dated and signed by an authorized user prior to the administration of radiation, except as specified in (d) of this subsection, containing the following information:

(a) For gamma stereotactic radiosurgery: Target coordinates, collimator size, plug pattern, and total dose;



(b) For teletherapy: The total dose, dose per fraction, treatment site, and overall treatment period;

(c) For high dose rate remote after loading brachytherapy: The radioisotope, treatment site, and total dose; or

(d) For all other brachytherapy, (i) prior to implantation: The radioisotope, number of sources, and source strengths; and (ii) after implantation but prior to completion of the procedure: The radioisotope, treatment site, and total source strength and exposure time (or, equivalently, the total dose).))

**Address of use** means the building or buildings that are identified on the license and where radioactive material may be received, prepared, used, or stored.

**Area of use** means a portion of an address of use that has been set aside for the purpose of receiving, preparing, using, or storing radioactive material.

**Authorized medical physicist** means an individual who:

(1) Meets the requirements in WAC 246-240-072 and 246-240-081; or

(2) Is identified as an authorized medical physicist or teletherapy physicist on a specific medical use license issued by the department, the U.S. Nuclear Regulatory Commission or agreement state prior to October 5, 2005.

(3) A permit issued by a commission or agreement state broad scope medical use licensee prior to October 5, 2005; or

(4) A permit issued by a commission master material license broad scope medical use permittee prior to October 5, 2005.

**Authorized nuclear pharmacist** means a pharmacist who:

(1) Meets the requirements in WAC 246-240-075 and 246-240-081; or

(2) Is identified as an authorized nuclear pharmacist on a specific license issued by the department, the U.S. NRC or agreement state prior to October 5, 2005, that authorizes medical use or the practice of nuclear pharmacy; or

(3) Is identified as an authorized nuclear pharmacist by a commercial nuclear pharmacy that has been authorized to identify authorized nuclear pharmacists; or

(4) A permit issued by a commission master material licensee that authorizes medical use or the practice of nuclear pharmacy;

(5) A permit issued by a commission or agreement state broad scope medical use licensee that authorizes medical use or the practice of nuclear pharmacy; or

(6) A permit issued by a commission master material license board scope medical use permittee that authorizes medical use or the practice of nuclear pharmacy; or

(7) Is designated as an authorized nuclear pharmacist in accordance with WAC 246-235-100(2).

**Authorized user** means a physician, dentist, or podiatrist who:

(1) Meets the requirements in WAC 246-240-081 and 246-240-154, 246-240-163, 246-240-210, 246-240-213, 246-240-216, 246-240-278, 246-240-301, or 246-240-399;

(2) Is identified as an authorized user on a department, U.S. NRC, or agreement state license prior to October 5, 2005, that authorizes the medical use of radioactive material.

(3) A permit issued by a commission master material licensee that is authorized to permit the medical use of by-product material;

(4) A permit issued by a commission or agreement state specific licensee of broad scope that is authorized to permit the medical use of by-product material; or

(5) A permit issued by a commission master material license broad scope permittee that is authorized to permit the medical use of by-product material.

**Brachytherapy** means a method of radiation therapy in which sources are used to deliver a radiation dose at a distance of up to a few centimeters by surface, intracavitary, intraluminal, or interstitial application.

**Brachytherapy source** means a radioactive source or a manufacturer-assembled source train or a combination of these sources that is designed to deliver a therapeutic dose within a distance of a few centimeters.

**Client's address** means the area of use or a temporary job site for the purpose of providing mobile medical service in accordance with WAC 246-240-125.

**Dedicated check source** means a radioactive source that is used to assure the constant operation of a radiation detection or measurement device over several months or years.

**Dentist** means an individual licensed by a state or territory of the United States, the District of Columbia, or the Commonwealth of Puerto Rico to practice dentistry.

**High dose-rate remote afterloader**, as used in this chapter, means a brachytherapy device that remotely delivers a dose rate in excess of 12 gray (1200 rads) per hour at the point or surface where the dose is prescribed.

**Low dose-rate remote afterloader**, as used in this chapter, means a brachytherapy device that remotely delivers a dose rate of less than or equal to 2 gray (200 rads) per hour at the point or surface where the dose is prescribed.

**Management** means the chief executive officer or other individual having the authority to manage, direct, or administer the licensee's activities, or that person's delegate or delegates.

**Manual brachytherapy**, as used in this chapter, means a type of brachytherapy in which the brachytherapy sources (e.g., seeds, ribbons) are manually placed topically on or inserted either into the body cavities that are in close proximity to a treatment site or directly into the tissue volume.

**Medical event** means an event that meets the criteria in WAC 246-240-651.

**Medical institution** means an organization in which more than one medical discipline is practiced.

**Medical use** means the intentional internal or external administration of radioactive material or the radiation from radioactive material to patients or human research subjects under the supervision of an authorized user.

**Medium dose-rate remote afterloader**, as used in this chapter, means a brachytherapy device that remotely delivers a dose rate of greater than 2 gray (200 rads), but less than or equal to 12 grays (1200 rads) per hour at the point or surface where the dose is prescribed.

**Mobile medical service** means the transportation of radioactive material to and its medical use at the client's address.

**Output** means the exposure rate, dose rate, or a quantity related in a known manner to these rates from a brachytherapy source or a teletherapy, remote afterloader, or gamma stereotactic radiosurgery unit for a specified set of exposure conditions.

**Patient intervention** means actions by the patient or human research subject, whether intentional or unintentional, such as dislodging or removing treatment devices or prematurely terminating the administration.

**Podiatrist** means an individual licensed by a state or territory of the United States, the District of Columbia, or the Commonwealth of Puerto Rico to practice podiatry.

**Preceptor** means an individual who provides, directs, or verifies training and experience required for an individual to become an authorized user, an authorized medical physicist, an authorized nuclear pharmacist, or a radiation safety officer.

**Prescribed dosage** means the specified activity or range of activity of unsealed radioactive material as documented:

(1) In a written directive; or

(2) In accordance with the directions of the authorized user for procedures performed under WAC 246-240-151 and 246-240-157.

**Prescribed dose** means:

(1) For gamma stereotactic radiosurgery, the total dose as documented in the written directive;

(2) For teletherapy, the total dose and dose per fraction as documented in the written directive;

(3) For manual brachytherapy, either the total source strength and exposure time or the total dose, as documented in the written directive; or

(4) For remote brachytherapy afterloaders, the total dose and dose per fraction as documented in the written directive.

**Pulsed dose-rate remote afterloader**, as used in this chapter, means a special type of remote afterloading brachytherapy device that uses a single source capable of delivering dose rates in the "high dose-rate" range, but:

(1) Is approximately one-tenth of the activity of typical high dose-rate remote afterloader sources; and

(2) Is used to simulate the radiobiology of a low dose-rate treatment by inserting the source for a given fraction of each hour.

**Radiation safety officer** means an individual who:

(1) Meets the requirements in WAC 246-240-069 and 246-240-081;

(2) Is identified as a radiation safety officer on a specific medical use license issued by the department prior to October 5, 2005, the U.S. NRC or an agreement state; or

(3) A medical use permit issued by a commission master material licensee.

**Sealed source and device registry** means the national registry that contains all the registration certificates, generated by both the U.S. NRC and the agreement states, that summarize the radiation safety information for the sealed sources and devices and describe the licensing and use conditions approved for the product.

**Stereotactic radiosurgery** means the use of external radiation in conjunction with a stereotactic guidance device to very precisely deliver a therapeutic dose to a tissue volume.

**Structured educational program** means an educational program designed to impart particular knowledge and practical education through interrelated studies and supervised training.

**Teletherapy**, as used in this chapter, means a method of radiation therapy in which collimated gamma rays are delivered at a distance from the patient or human research subject.

**Temporary job site** means a location where mobile medical services are conducted other than those location(s) of use authorized on the license.

**Therapeutic dosage** means a dosage of unsealed radioactive material that is intended to deliver a radiation dose to a patient or human research subject for palliative or curative treatment.

**Therapeutic dose** means a radiation dose delivered from a source containing radioactive material to a patient or human research subject for palliative or curative treatment.

**Treatment site** means the anatomical description of the tissue intended to receive a radiation dose, as described in a written directive.

**Type of use** means use of radioactive material under WAC 246-240-151, 246-240-157, 246-240-201, 246-240-251, 246-240-301, 246-240-351, or 246-240-501.

**Unit dosage** means a dosage prepared for medical use for administration as a single dosage to a patient or human research subject without any further manipulation of the dosage after it is initially prepared.

**Written directive** means an authorized user's written order for the administration of radioactive material or radiation from radioactive material to a specific patient or human research subject, as specified in WAC 246-240-060.

## NEW SECTION

**WAC 246-240-013 Maintenance of records.** Each record required by this chapter must be legible throughout the retention period specified by each department regulation. The record may be the original or a reproduced copy or a microform provided that the copy or microform is authenticated by authorized personnel and that the microform is capable of producing a clear copy throughout the required retention period. The record may also be stored in electronic media with the capability for producing legible, accurate, and complete records during the required retention period. Records such as letters, drawings, and specifications, must include all pertinent information such as stamps, initials, and signatures. The licensee shall maintain adequate safeguards against tampering with and loss of records.

## NEW SECTION

**WAC 246-240-016 License required.** (1) A person may manufacture, produce, acquire, receive, possess, prepare, use, or transfer radioactive material for medical use only in accordance with a specific license issued by the department, the U.S. NRC or an agreement state, or as allowed in subsection (2)(a) or (b) of this section.

(2) A specific license is not needed for an individual who:

(a) Receives, possesses, uses, or transfers radioactive material in accordance with these rules under the supervision

of an authorized user under in WAC 246-240-057, unless prohibited by license condition; or

(b) Prepares unsealed radioactive material for medical use in accordance with these rules under the supervision of an authorized nuclear pharmacist or authorized user under WAC 246-240-057, unless prohibited by license condition.

#### NEW SECTION

**WAC 246-240-019 Application for license, amendment, or renewal.** (1) An application must be signed by the applicant's or licensee's management.

(2) An application for a license for medical use of radioactive material as described in WAC 246-240-151, 246-240-157, 246-240-201, 246-240-251, 246-240-301, 246-240-351, and 246-240-501 must be made by:

(a) Filing the original "**Application for Radioactive Material License Medical**," with the department that includes the facility diagram, equipment, and training and experience qualifications of the radiation safety officer, authorized user(s), authorized medical physicist(s), and authorized nuclear pharmacist(s); and

(b) Submitting applicable procedures required by WAC 246-240-360, 246-240-378, 246-240-381, and 246-240-384.

(3) A request for a license amendment or renewal must be made by:

(a) Submitting an original of either to the department:

(i) "**Application for Radioactive Material License Medical**"; or

(ii) A letter requesting the amendment or renewal; and

(b) Submitting applicable procedures required by WAC 246-240-360, 246-240-378, 246-240-381, and 246-240-384.

(4) In addition to the requirements in subsections (2) and (3) of this section, an application for a license or amendment for medical use of radioactive material as described in WAC 246-240-501 must also include information regarding any radiation safety aspects of the medical use of the material that is not addressed in this chapter.

(a) The applicant shall also provide specific information on:

(i) Radiation safety precautions and instructions;

(ii) Methodology for measurement of dosages or doses to be administered to patients or human research subjects; and

(iii) Calibration, maintenance, and repair of instruments and equipment necessary for radiation safety.

(b) The applicant or licensee shall also provide any other information requested by the department in its review of the application.

(5) An applicant that satisfies the requirements specified in WAC 246-235-090 may apply for a Type A specific license of broad scope.

#### NEW SECTION

**WAC 246-240-022 License amendments.** A licensee shall apply for and must receive a license amendment before the licensee:

(1) Receives, prepares, or uses radioactive material for a type of use that is permitted under this chapter, but that is not authorized on the licensee's current license issued under this chapter;

(2) Permits anyone to work as an authorized user, authorized nuclear pharmacist, or authorized medical physicist under the license, except:

(a) For an authorized user, an individual who meets the requirements in WAC 246-240-154, 246-240-163, 246-240-210, 246-240-213, 246-240-216, 246-240-278, or 246-240-399;

(b) For an authorized nuclear pharmacist, an individual who meets the requirements in WAC 246-240-075 and 246-240-081;

(c) For an authorized medical physicist, an individual who meets the requirements in WAC 246-240-072 and 246-240-081;

(d) An individual who is identified as an authorized user, an authorized nuclear pharmacist, or authorized medical physicist:

(i) On an agreement state or U.S. NRC license or other equivalent license recognized by the department that authorizes the use of radioactive material in medical use or in the practice of nuclear pharmacy; or

(ii) On a permit issued by a commission or agreement state specific license of broad scope that is authorized to permit the use of by-product material in medical use or in the practice of nuclear pharmacy;

(iii) On a permit issued by a commission master material licensee that is authorized to permit the use of by-product material in medical use or in the practice of nuclear pharmacy; or

(iv) By a commercial nuclear pharmacy that has been authorized to identify authorized nuclear pharmacists.

(3) Changes radiation safety officers, except as provided in WAC 246-240-051;

(4) Receives radioactive material in excess of the amount or in a different form, or receives a different radionuclide than is authorized on the license;

(5) Adds to or changes the areas of use identified in the application or on the license, except for areas of use where radioactive material is used only in accordance with either WAC 246-240-151 or 246-240-157;

(6) Changes the address(es) of use identified in the application or on the license; and

(7) Revises procedures required by WAC 246-240-360, 246-240-378, 246-240-381, and 246-240-384, as applicable, where the revision reduces radiation safety.

**AMENDATORY SECTION** (Amending WSR 98-13-037, filed 6/8/98, effective 7/9/98)

**WAC 246-240-025 (~~Release of individuals containing permanent implants.~~) Notifications.** (1) (~~The licensee may authorize the release from its control of any individual who has permanent implants containing radioactive material if the total effective dose equivalent to any other individual from exposure to the released individual is not likely to exceed 5 millisieverts (0.5 rem).~~)

(2) ~~The licensee shall provide the released individual with instructions, including written instructions, on actions recommended to maintain doses to other individuals as low as is reasonably achievable if the total effective dose equivalent~~

lent to any other individual is likely to exceed 1 millisievert (0.1 rem):

(3) ~~The licensee shall maintain a record of the basis for authorizing the release of an individual, for three years after the date of release, if the total effective dose equivalent is calculated by:~~

~~(a) Using an occupancy factor less than 0.25 at 1 meter; or~~

~~(b) Considering the shielding by tissue.)~~ A licensee shall notify the department no later than thirty days after:

(a) An authorized user, an authorized nuclear pharmacist, a radiation safety officer, or an authorized medical physicist permanently discontinues performance of duties under the license or has a name change;

(b) The licensee's mailing address changes;

(c) The licensee's name changes, but the name change does not constitute a transfer of control of the license as described in WAC 246-232-050(2); or

(d) The licensee has added to or changed the areas of use identified in the application or on the license where radioactive material is used under either WAC 246-240-151 or 246-240-157.

(2) The licensee shall send the documents required in this section to the department at P.O. Box 47827, Olympia WA 98504-7827.

#### NEW SECTION

**WAC 246-240-028 Exemptions regarding Type A specific licenses of broad scope.** A licensee possessing a Type A specific license of broad scope for medical use, issued under WAC 246-235-090, is exempt from the provisions of:

(1) WAC 246-240-019 regarding the need to file an amendment to the license for medical use of radioactive material, as described in WAC 246-240-501;

(2) WAC 246-240-022;

(3) WAC 246-240-022 regarding additions to or changes in the areas of use at the addresses identified in the application or on the license;

(4) WAC 246-240-025;

(5) WAC 246-240-025 for an authorized user, an authorized nuclear pharmacist, or an authorized medical physicist;

(6) WAC 246-240-025 regarding additions to or changes in the areas of use identified in the application or on the license where radioactive material is used in accordance with either WAC 246-240-151 or 246-240-157;

(7) WAC 246-240-122.

#### NEW SECTION

**WAC 246-240-031 License issuance and specific exemptions.** (1) The department shall issue a license for the medical use of radioactive material if:

(a) The applicant has filed "Application for Radioactive Material License Medical" in accordance with the instructions in WAC 246-240-019;

(b) The applicant has paid applicable fee under chapter 246-254 WAC;

(c) The department finds the applicant equipped and committed to observe the safety standards established by the

department in these regulations for the protection of the public health and safety; and

(d) The applicant meets the requirements of chapter 246-232 WAC.

(2) The department shall issue a license for mobile medical service if the applicant:

(a) Meets the requirements in subsection (1) of this section; and

(b) Assures that individuals or human research subjects to whom unsealed radioactive material, or radiation from implants containing radioactive material, will be administered may be released following treatment in accordance with WAC 246-240-122.

(3) The department may, upon application of any interested person or upon its own initiative, grant exemptions from this chapter that it determines are authorized by law and will not endanger life or property or the common defense and security and are otherwise in the public interest.

#### NEW SECTION

**WAC 246-240-051 Authority and responsibilities for the radiation protection program.** (1) In addition to the radiation protection program requirements of WAC 246-221-005, a licensee's management shall approve in writing:

(a) Requests for a license application, renewal, or amendment before submittal to the department;

(b) Any individual before allowing that individual to work as an authorized user, authorized nuclear pharmacist, or authorized medical physicist; and

(c) Radiation protection program changes that do not require a license amendment and are permitted under WAC 246-240-054;

(2) A licensee's management shall appoint a radiation safety officer, who agrees, in writing, to be responsible for implementing the radiation protection program. The licensee, through the radiation safety officer, shall ensure that radiation safety activities are being performed in accordance with licensee-approved procedures and regulatory requirements.

(3) For up to sixty days each year, a licensee may permit an authorized user or an individual qualified to be a radiation safety officer, under WAC 246-240-069 and 246-240-081, to function as a temporary radiation safety officer and to perform the functions of a radiation safety officer, under subsection (7) of this section, if the licensee takes the actions required in subsections (2), (5), (7), and (8) of this section and notifies the department in accordance with WAC 246-240-025.

(4) A licensee may simultaneously appoint more than one temporary radiation safety officer under subsection (3) of this section, if needed to ensure that the licensee has a temporary radiation safety officer that satisfies the requirements to be a radiation safety officer for each of the different types of uses of radioactive material permitted by the license.

(5) A licensee shall establish the authority, duties, and responsibilities of the radiation safety officer in writing.

(6) Licensees that are authorized for two or more different types of use of radioactive material under WAC 246-240-201, 246-240-251, and/or 246-240-351, shall establish a radi-

ation safety committee to oversee all uses of radioactive material permitted by the license. The committee must include an authorized user of each type of use permitted by the license, the radiation safety officer, a representative of the nursing service, and a representative of management who is neither an authorized user nor a radiation safety officer. The committee may include other members the licensee considers appropriate.

(7) A licensee shall provide the radiation safety officer sufficient authority, organizational freedom, time, resources, and management prerogative, to:

- (a) Identify radiation safety problems;
- (b) Initiate, recommend, or provide corrective actions;
- (c) Stop unsafe operations; and
- (d) Verify implementation of corrective actions.

(8) A licensee shall retain a record of actions taken under subsections (1), (2), and (5) of this section in accordance with WAC 246-240-551.

#### NEW SECTION

**WAC 246-240-054 Radiation protection program changes.** (1) A licensee may revise its radiation protection program without department approval if:

- (a) The revision does not require a license amendment under WAC 246-240-022;
- (b) The revision is in compliance with this chapter and the license;
- (c) The revision has been reviewed and approved by the radiation safety officer and licensee management; and
- (d) The affected individuals are instructed on the revised program before the changes are implemented.

(2) A licensee shall retain a record of each change in accordance with WAC 246-240-554.

#### NEW SECTION

**WAC 246-240-057 Supervision.** (1) A licensee that permits the receipt, possession, use, or transfer of radioactive material by an individual under the supervision of an authorized user, as allowed by WAC 246-240-016, shall in addition to the requirements in WAC 246-222-030:

(a) Instruct the supervised individual in the licensee's written radiation protection procedures, written directive procedures, this chapter, and license conditions with respect to the use of radioactive material; and

(b) Require the supervised individual to follow the instructions of the supervising authorized user for medical uses of radioactive material, written radiation protection procedures established by the licensee, written directive procedures, regulations of these regulations, and license conditions with respect to the medical use of radioactive material.

(2) A licensee that permits the preparation of radioactive material for medical use by an individual under the supervision of an authorized nuclear pharmacist or physician who is an authorized user, as allowed by WAC 246-240-016, shall:

(a) In addition to the requirements in WAC 246-222-030, instruct the supervised individual in the preparation of radioactive material for medical use, as appropriate to that individual's involvement with radioactive material; and

(b) Require the supervised individual to follow the instructions of the supervising authorized user or authorized nuclear pharmacist regarding the preparation of radioactive material for medical use, written radiation protection procedures established by the licensee, this chapter, and license conditions.

(c) A licensee that permits supervised activities under subsections (1) and (2) of this section is responsible for the acts and omissions of the supervised individual.

#### NEW SECTION

**WAC 246-240-060 Written directives.** (1) A written directive must be dated and signed by an authorized user before the administration of I-131 sodium iodide greater than 1.11 megabecquerels (MBq) (30 microcuries ( $\mu\text{Ci}$ )), any therapeutic dosage of unsealed radioactive material or any therapeutic dose of radiation from radioactive material.

If, because of the emergent nature of the patient's condition, a delay in order to provide a written directive would jeopardize the patient's health, an oral directive is acceptable. The information contained in the oral directive must be documented as soon as possible in writing in the patient's record. A written directive must be prepared within forty-eight hours of the oral directive.

(2) The written directive must contain the patient or human research subject's name and the following information:

(a) For any administration of quantities greater than 1.11 MBq (30  $\mu\text{Ci}$ ) of sodium iodide I-131: The dosage;

(b) For an administration of a therapeutic dosage of unsealed radioactive material other than sodium iodide I-131: The radioactive drug, dosage, and route of administration;

(c) For gamma stereotactic radiosurgery: The total dose, treatment site, and values for the target coordinate settings per treatment for each anatomically distinct treatment site;

(d) For teletherapy: The total dose, dose per fraction, number of fractions, and treatment site;

(e) For high dose-rate remote afterloading brachytherapy: The radionuclide, treatment site, dose per fraction, number of fractions, and total dose; or

(f) For all other brachytherapy, including low, medium, and pulsed dose rate remote afterloaders:

(i) Before implantation: Treatment site, the radionuclide, and dose; and

(ii) After implantation but before completion of the procedure: The radionuclide, treatment site, number of sources, and total source strength and exposure time (or the total dose). (3) A written revision to an existing written directive may be made if the revision is dated and signed by an authorized user before the administration of the dosage of unsealed radioactive material, the brachytherapy dose, the gamma stereotactic radiosurgery dose, the teletherapy dose, or the next fractional dose.

If, because of the patient's condition, a delay in order to provide a written revision to an existing written directive would jeopardize the patient's health, an oral revision to an existing written directive is acceptable. The oral revision must be documented as soon as possible in the patient's

record. A revised written directive must be signed by the authorized user within forty-eight hours of the oral revision.

(4) The licensee shall retain a copy of the written directive in accordance with WAC 246-240-557.

#### NEW SECTION

**WAC 246-240-063 Procedures for administrations requiring a written directive.** (1) For any administration requiring a written directive, the licensee shall develop, implement, and maintain written procedures to provide high confidence that:

(a) The patient's or human research subject's identity is verified before each administration; and

(b) Each administration is in accordance with the written directive.

(2) At a minimum, the procedures required by subsection (1) of this section must address the following items that are applicable to the licensee's use of radioactive material:

(a) Verifying the identity of the patient or human research subject;

(b) Verifying that the administration is in accordance with the treatment plan, if applicable, and the written directive;

(c) Checking both manual and computer-generated dose calculations; and

(d) Verifying that any computer-generated dose calculations are correctly transferred into the consoles of therapeutic medical units authorized by WAC 246-240-351.

(3) A licensee shall retain a copy of the procedures required under subsection (1) of this section in accordance with WAC 246-240-560.

#### NEW SECTION

**WAC 246-240-066 Suppliers for sealed sources or devices for medical use.** For medical use, a licensee may only use:

(1) Sealed sources or devices manufactured, labeled, packaged, and distributed in accordance with a license issued under WAC 246-235-102.

(2) Sealed sources or devices noncommercially transferred from a U.S. NRC or agreement state licensee; or

(3) Teletherapy sources manufactured and distributed in accordance with a license issued under chapter 246-232 WAC.

#### NEW SECTION

**WAC 246-240-069 Training for radiation safety officer.** Except as provided in WAC 246-240-078, the licensee shall require an individual fulfilling the responsibilities of the radiation safety officer under WAC 246-240-051 to be an individual who:

(1) Is certified by a specialty board whose certification process has been recognized by the department, the U.S. NRC, or an agreement state. (Specialty boards whose certification process has been recognized by the department, the U.S. Nuclear Regulatory Commission or an agreement state will be posted on the NRC's web page, at <http://www.nrc.gov>.)

To be recognized, a specialty board shall require all candidates for certification to:

(a) Hold a bachelor's or graduate degree from an accredited college or university in physical science or engineering or biological science with a minimum of twenty college credits in physical science;

(b) Have five or more years of professional experience in health physics (graduate training may be substituted for no more than two years of the required experience) including at least three years in applied health physics;

(c) Pass an examination administered by diplomates of the specialty board, which evaluates knowledge and competence in radiation physics and instrumentation, radiation protection, mathematics pertaining to the use and measurement of radioactivity, radiation biology, and radiation dosimetry; or

(i) Hold a master's or doctor's degree in physics, medical physics, other physical science, engineering, or applied mathematics from an accredited college or university;

(ii) Have two years of full-time practical training and/or supervised experience in medical physics;

(A) Under the supervision of a medical physicist who is certified in medical physics by a specialty board recognized by the commission or an agreement state; or

(B) In clinical nuclear medicine facilities providing diagnostic and/or therapeutic services under the direction of physicians who meet the requirements for authorized users under these rules before October 24, 2005; and

(iii) Pass an examination, administered by diplomates of the specialty board, that assesses knowledge and competence in clinical diagnostic radiological or nuclear medicine physics and in radiation safety; or

(d) Obtain written certification signed by a preceptor radiation safety officer that the individual has achieved a level of radiation safety knowledge sufficient to function independently as a radiation safety officer for a medical use licensee; or

(2)(a) Has completed a structured educational program consisting of both:

(i) Two hundred hours of didactic training in the following areas:

(A) Radiation physics and instrumentation;

(B) Radiation protection;

(C) Mathematics pertaining to the use and measurement of radioactivity;

(D) Radiation biology; and

(E) Radiation dosimetry; and

(ii) One year of full-time radiation safety experience under the supervision of the individual identified as the radiation safety officer on a department or agreement state license or license issued by the U.S. NRC that authorizes similar type(s) of use(s) of radioactive material involving the following:

(A) Shipping, receiving, and performing related radiation surveys;

(B) Using and performing checks for proper operation of instruments used to determine the activity of dosages, survey meters, and instruments used to measure radionuclides;

(C) Securing and controlling radioactive material;

(D) Using administrative controls to avoid mistakes in the administration of radioactive material;

(E) Using procedures to prevent or minimize radioactive contamination and using proper decontamination procedures;

(F) Using emergency procedures to control radioactive material; and

(G) Disposing of radioactive material; and

(b) Is a medical physicist who has been certified by a specialty board whose certification process has been recognized by the commission or an agreement state under WAC 246-240-072 and has experience in radiation safety for similar types of use of by-product material for which the licensee is seeking the approval of the individual as radiation safety officer and who meets the requirements in (d) and (e) of this subsection; or

(3) Is an authorized user, authorized medical physicist, or authorized nuclear pharmacist identified on the licensee's license or a medical physicist who has been certified by a specialty board whose certification process has been recognized by the department, the U.S. Nuclear Regulatory Commission or an agreement state under WAC 246-240-072 and has experience with the radiation safety aspects of similar types of use of radioactive material for which the individual has radiation safety officer responsibilities; and

(4) Has obtained written certification, signed by a preceptor radiation safety officer, that the individual has satisfactorily completed the requirements in (a) of this subsection and has achieved a level of radiation safety knowledge sufficient to function independently as a radiation safety officer for a medical use licensee; and

(5) Has training in the radiation safety, regulatory issues, and emergency procedures for the types of use for which a licensee seeks approval. This training requirement may be satisfied by completing training that is supervised by an authorized medical physicist, authorized user, authorized nuclear pharmacist, or radiation safety officer, as appropriate, who is authorized for the type(s) of use for which the licensee is seeking approval.

#### NEW SECTION

**WAC 246-240-072 Training for an authorized medical physicist.** Except as provided in WAC 246-240-078, the licensee shall require the authorized medical physicist to be an individual who:

(1) Is certified by a specialty board whose certification process has been recognized by the department, the U.S. Nuclear Regulatory Commission or an agreement state and who meets the requirements in subsections (2)(b) and (3) of this section. (Specialty boards whose certification process has been recognized by the commission or an agreement state will be posted on the NRC's web page at <http://www.nrc.gov>.) To be recognized, a specialty board shall require all candidates for certification to:

(a) Hold a master's or doctor's degree in physics, medical physics, other physical science, engineering, or applied mathematics from an accredited college or university;

(b) Have two years of full-time practical training and/or supervised experience in medical physics:

(i) Under the supervision of a medical physicist who is certified in medical physics by a specialty board recognized by the commission or an agreement state; or

(ii) In clinical radiation facilities providing high energy, external beam therapy and brachytherapy services under the direction of physicians who meet the requirements for authorized users in WAC 246-240-278 or 246-240-399;

(c) Pass an examination, administered by diplomates of the specialty board, which assesses knowledge and competence in clinical radiation therapy, radiation safety, calibration, quality assurance, and treatment planning for external beam therapy, brachytherapy, and stereotactic radiosurgery; or

(2)(a) Holds a master's or doctor's degree in physics, medical physics, other physical science, engineering, or applied mathematics from an accredited college or university; and has completed one year of full-time training in medical physics and an additional year of full-time work experience under the supervision of an individual who meets the requirements for an authorized medical physicist for the type(s) of use modalities for which the individual is seeking authorization. This training and work experience must be conducted in clinical radiation facilities that provide high energy, external beam therapy and brachytherapy services and must include:

(i) Performing sealed source leak tests and inventories;

(ii) Performing decay corrections;

(iii) Performing full calibration and periodic spot checks of external beam treatment units, stereotactic radiosurgery units, and remote afterloading units as applicable; and

(iv) Conducting radiation surveys around external beam treatment units, stereotactic radiosurgery units, and remote afterloading units as applicable; and

(b) Has obtained written certification that the individual has satisfactorily completed the requirements in subsections (1)(a) and (b) and (3), or (2)(a) and (3) of this section, and has achieved a level of competency sufficient to function independently as an authorized medical physicist for each type of therapeutic medical unit for which the individual is requesting authorized medical physicist status. The written certification must be signed by a preceptor authorized medical physicist who meets the requirements in WAC 246-240-072 or equivalent U.S. NRC or agreement state requirements for an authorized medical physicist for each type of therapeutic medical unit for which the individual is requesting authorized medical physicist status; and

(3) Has training for the type(s) of use in the modalities for which authorization is sought that includes hands-on device operation, safety procedures, clinical use, and the operation of a treatment planning system. This training requirement may be satisfied by satisfactorily completing either a training program provided by the vendor or by training supervised by an authorized medical physicist authorized for the type(s) of use for which the individual is seeking authorization.

#### NEW SECTION

**WAC 246-240-075 Training for an authorized nuclear pharmacist.** Except as provided in WAC 246-240-

078, the licensee shall require the authorized nuclear pharmacist to be a pharmacist who:

(1) Is certified by a specialty board whose certification process has been recognized by the department, the U.S. Nuclear Regulatory Commission or an agreement state and who meets the requirements in subsection (2)(b) of this section. (Specialty boards whose certification process has been recognized by the commission or an agreement state will be posted on the NRC's web page at <http://www.nrc.gov>.) To be recognized, a specialty board shall require all candidates for certification to:

(a) Have graduated from a pharmacy program accredited by the American Council On Pharmaceutical Education (ACPE) or have passed the Foreign Pharmacy Graduate Examination Committee (FPGEC) examination;

(b) Hold a current, active license to practice pharmacy;

(c) Provide evidence of having acquired at least four thousand hours of training/experience in nuclear pharmacy practice. Academic training may be substituted for no more than two thousand hours of the required training and experience; and

(d) Pass an examination in nuclear pharmacy administered by diplomates of the specialty board, which assesses knowledge and competency in procurement, compounding, quality assurance, dispensing, distribution, health and safety, radiation safety, provision of information and consultation, monitoring patient outcomes, research and development; or

(2)(a) Has completed two hundred hours in a structured educational program consisting of both:

(i) Didactic training in the following areas:

(A) Radiation physics and instrumentation;

(B) Radiation protection;

(C) Mathematics pertaining to the use and measurement of radioactivity;

(D) Chemistry of radioactive material for medical use; and

(E) Radiation biology; and

(ii) Supervised practical experience in a nuclear pharmacy involving:

(A) Shipping, receiving, and performing related radiation surveys;

(B) Using and performing checks for proper operation of instruments used to determine the activity of dosages, survey meters, and, if appropriate, instruments used to measure alpha-or beta-emitting radionuclides;

(C) Calculating, assaying, and safely preparing dosages for patients or human research subjects;

(D) Using administrative controls to avoid medical events in the administration of radioactive material; and

(E) Using procedures to prevent or minimize radioactive contamination and using proper decontamination procedures; and

(b) Has obtained written certification, signed by a precursor authorized nuclear pharmacist, that the individual has satisfactorily completed the requirements in subsections (1)(a), (b), and (c) or (2)(a) of this section and has achieved a level of competency sufficient to function independently as an authorized nuclear pharmacist.

#### NEW SECTION

**WAC 246-240-078 Training for experienced radiation safety officer, teletherapy or medical physicist, authorized user, and nuclear pharmacist.** (1) An individual identified as a radiation safety officer, a teletherapy or medical physicist, or a nuclear pharmacist on a department, U.S. NRC, or agreement state license, or a permit issued by an agreement state or U.S. NRC broad scope licensee or master material license permit, or by a master material license permittee of broad scope before October 24, 2006, need not comply with the training requirements of WAC 246-240-278, 246-240-072, or 246-240-075, respectively.

(2) Physicians, dentists, or podiatrists identified as authorized users for the medical use of radioactive material on a license issued by the department or agreement state, or U.S. NRC broad scope license, or license issued before October 24, 2006, who perform only those medical uses for which they were authorized on that date need not comply with the training requirements of WAC 246-240-151 and 246-240-399.

#### NEW SECTION

**WAC 246-240-081 Recency of training.** Training and experience specified in WAC 246-240-069, 246-240-072, 246-240-075, 246-240-078, 246-240-154, 246-240-163, 246-240-210, 246-240-213, 246-240-216, 246-240-278, 246-240-281, 246-240-399, and 246-240-451 through 246-240-487 (inclusive), must have been obtained within the seven years preceding the date of application or the individual must have had related continuing education and experience since the required training and experience was completed.

#### NEW SECTION

**WAC 246-240-101 Possession, use, and calibration of instruments used to measure the activity of unsealed radioactive material.** (1) For direct measurements performed in accordance with WAC 246-240-107, a licensee shall possess and use instrumentation to measure the activity of unsealed radioactive material before it is administered to each patient or human research subject.

(2) A licensee shall calibrate the instrumentation required in subsection (1) of this section in accordance with nationally recognized standards or the manufacturer's instructions.

(3) A licensee shall retain a record of each instrument calibration required by this section in accordance with WAC 246-240-563.

#### NEW SECTION

**WAC 246-240-104 Calibration of survey instruments.** (1) A licensee shall calibrate the survey instruments used to show compliance with this section and WAC 246-240-587 before first use, annually, and following a repair that affects the calibration. A licensee shall:

(a) Calibrate all scales with readings up to 10 mSv (1000 mrem) per hour with a radiation source;



(b) Calibrate two separated readings on each scale or decade that will be used to show compliance; and

(c) Conspicuously note on the instrument the date of calibration.

(2) A licensee may not use survey instruments if the difference between the indicated exposure rate and the calculated exposure rate is more than twenty percent.

(3) A licensee shall retain a record of each survey instrument calibration in accordance with WAC 246-240-566.

#### NEW SECTION

**WAC 246-240-107 Determination of dosages of unsealed radioactive material for medical use.** (1) A licensee shall determine and record the activity of each dosage before medical use.

(2) For a unit dosage, this determination must be made by:

(a) Direct measurement of radioactivity; or

(b) A decay correction, based on the activity or activity concentration determined by:

(i) A manufacturer or preparer licensed under WAC 246-235-100 or equivalent U.S. NRC or agreement state requirements; or

(ii) An agreement state or U.S. NRC licensee for use in research in accordance with a radioactive drug research committee-approved protocol or an investigational new drug (IND) protocol accepted by FDA.

(3) For other than unit dosages, this determination must be made by:

(a) Direct measurement of radioactivity;

(b) Combination of measurement of radioactivity and mathematical calculations; or

(c) Combination of volumetric measurements and mathematical calculations, based on the measurement made by a manufacturer or preparer licensed under WAC 246-235-100 or equivalent agreement state requirements.

(4) Unless otherwise directed by the authorized user, a licensee may not use a dosage if the dosage does not fall within the prescribed dosage range or if the dosage differs from the prescribed dosage by more than twenty percent.

(5) A licensee shall retain a record of the dosage determination required by this section in accordance with WAC 246-240-569.

#### NEW SECTION

**WAC 246-240-110 Authorization for calibration, transmission, and reference sources.** Any person authorized by WAC 246-240-016 for medical use of radioactive material may receive, possess, and use any of the following radioactive material for check, calibration, transmission, and reference use:

(1) Sealed sources, not exceeding 1.11 GBq (30 mCi) each, manufactured and distributed by a person licensed under WAC 246-235-102 or equivalent agreement state or U.S. NRC regulations.

(2) Sealed sources, not exceeding 1.11 GBq (30 mCi) each, redistributed by a licensee authorized to redistribute the sealed sources manufactured and distributed by a person licensed under WAC 246-235-102, if the redistributed sealed

sources are in the original packaging and shielding and are accompanied by the manufacturer's approved instructions.

(3) Any radioactive material with a half-life not longer than one hundred twenty days in individual amounts not to exceed 0.56 GBq (15 mCi).

(4) Any radioactive material with a half-life longer than one hundred twenty days in individual amounts not to exceed the smaller of 7.4 MBq (200  $\mu$ Ci) or 1000 times the quantities in Schedule B of WAC 246-232-120.

(5) Technetium-99m in amounts as needed.

#### NEW SECTION

**WAC 246-240-113 Requirements for possession of sealed sources and brachytherapy sources.** (1) A licensee in possession of any sealed source or brachytherapy source shall follow the radiation safety and handling instructions supplied by the manufacturer.

(2) A licensee in possession of a sealed source shall:

(a) Test the source for leakage before its first use unless the licensee has a certificate from the supplier indicating that the source was tested within six months before transfer to the licensee; and

(b) Test the source for leakage at intervals not to exceed six months or at other intervals approved by the department, the U.S. NRC, or an agreement state in the sealed source and device registry.

(3) To satisfy the leak test requirements of this section, the licensee shall ensure the sample is analyzed by such method that the leak test can detect the presence of 185 Bq (0.005  $\mu$ Ci) of radioactive material in the sample.

(4) A licensee shall retain leak test records in accordance with WAC 246-240-572(1).

(5) If the leak test reveals the presence of 185 Bq (0.005  $\mu$ Ci) or more of removable contamination, the licensee shall:

(a) Immediately withdraw the sealed source from use and store, dispose, or cause it to be repaired in accordance with the requirements in chapters 246-221 and 246-232 WAC; and

(b) File a report within five days of the leak test in accordance with WAC 246-240-657.

(6) A licensee need not perform a leak test on the following sources:

(a) Sources containing only radioactive material with a half-life of less than thirty days;

(b) Sources containing only radioactive material as a gas;

(c) Sources containing 3.7 MBq (100  $\mu$ Ci) or less of beta-or gamma-emitting material or 0.37 MBq (10  $\mu$ Ci) or less of alpha-emitting material;

(d) Seeds of iridium-192 encased in nylon ribbon; and

(e) Sources stored and not being used. However, the licensee shall test each source for leakage before any use or transfer unless it has been leak tested within six months before the date of use or transfer.

(7) A licensee in possession of sealed sources or brachytherapy sources, except for gamma stereotactic radiosurgery sources, shall conduct a physical inventory of all the sources in its possession at intervals not to exceed six months. The licensee shall retain each inventory record in accordance with WAC 246-240-572.

NEW SECTION**WAC 246-240-116 Labeling of vials and syringes.**

Each syringe and vial that contains unsealed radioactive material must be labeled to identify the radioactive drug. Each syringe shield and vial shield must also be labeled unless the label on the syringe or vial is visible when shielded.

NEW SECTION

**WAC 246-240-119 Surveys of ambient radiation exposure rate.** (1) In addition to the surveys required by chapter 246-221 WAC, a licensee shall survey with a radiation detection survey instrument at the end of each day of use. A licensee shall survey all areas where unsealed radioactive material requiring a written directive was prepared for use or administered.

(2) A licensee does not need to perform the surveys required by subsection (1) of this section in an area(s) where patients or human research subjects are confined when they cannot be released under WAC 246-240-122.

(3) A licensee shall retain a record of each survey in accordance with WAC 246-240-575.

NEW SECTION

**WAC 246-240-122 Release of individuals containing unsealed radioactive material or implants containing radioactive material.** (1) A licensee may authorize the release from its control of any individual who has been administered unsealed radioactive material or implants containing radioactive material if the total effective dose equivalent to any other individual from exposure to the released individual is not likely to exceed 5 mSv (0.5 rem).

(2) A licensee shall provide the released individual, or the individual's parent or guardian, with instructions, including written instructions, on actions recommended to maintain doses to other individuals as low as is reasonably achievable if the total effective dose equivalent to any other individual is likely to exceed 1 mSv (0.1 rem). If the total effective dose equivalent to a nursing infant or child could exceed 1 mSv (0.1 rem) assuming there were no interruption of breast-feeding, the instructions must also include:

(a) Guidance on the interruption or discontinuation of breast-feeding; and

(b) Information on the potential consequences, if any, of failure to follow the guidance.

(3) A licensee shall maintain a record of the basis for authorizing the release of an individual in accordance with WAC 246-240-578(1).

(4) The licensee shall maintain a record of instructions provided to a breast-feeding female in accordance with WAC 246-240-578(2). NUREG-1556, Vol. 9, "*Consolidated Guidance About Materials Licenses: Program-Specific Guidance About Medical Licenses*," describes methods for calculating doses to other individuals and contains tables of activities not likely to cause doses exceeding 5 mSv (0.5 rem).

NEW SECTION

**WAC 246-240-125 Provision of mobile medical service.** (1) A licensee who provides mobile medical service shall:

(a) Obtain a letter signed by the management of each client to whom services are rendered that permits the use of radioactive material at the client's address and clearly delineates the authority and responsibility of the licensee and the client;

(b) Check instruments used to measure the activity of unsealed radioactive material for proper function before medical use at each client's address or on each day of use, whichever is more frequent. At a minimum, the check for proper function required by this section must include a constancy check;

(c) Check survey instruments for proper operation with a dedicated check source before use at each client's address; and

(d) Before leaving a client's address, survey all areas of use to ensure compliance with chapter 246-221 WAC.

(2) A mobile medical service may not have radioactive material delivered from the manufacturer or the distributor to the client unless the client has a license allowing possession of the radioactive material. Radioactive material delivered to the client must be received and handled in conformance with the client's license.

(3) A licensee providing mobile medical services shall retain the letter required in subsection (1)(a) of this section and the record of each survey required in subsection (1)(d) of this section in accordance with WAC 246-240-581.

NEW SECTION

**WAC 246-240-128 Decay-in-storage.** (1) A licensee may hold radioactive material with a physical half-life of less than one hundred twenty days for decay-in-storage before disposal without regard to its radioactivity if it:

(a) Monitors radioactive material at the surface before disposal and determines that its radioactivity cannot be distinguished from the background radiation level with an appropriate radiation detection survey meter set on its most sensitive scale and with no interposed shielding; and

(b) Removes or obliterates all radiation labels, except for radiation labels on materials that are within containers and that will be managed as biomedical waste after they have been released from the licensee.

(2) A licensee shall retain a record of each disposal permitted under subsection (1) of this section in accordance with WAC 246-240-584.

NEW SECTION

**WAC 246-240-151 Use of unsealed radioactive material for uptake, dilution, and excretion studies for which a written directive is not required.** Except for quantities that require a written directive under WAC 246-240-060(2), a licensee may use any unsealed radioactive material prepared for medical use for uptake, dilution, or excretion studies that is:

(1) Obtained from a manufacturer or preparer licensed under WAC 246-235-100(1) or equivalent U.S. NRC or agreement state requirements; or

(2) Prepared by an authorized nuclear pharmacist, a physician who is an authorized user and who meets the requirements specified in WAC 246-240-163 or 246-240-210, or an individual under the supervision of either as specified in WAC 246-240-057; or

(3) Obtained from and prepared by an agreement state or U.S. NRC licensee for use in research in accordance with a radioactive drug research committee-approved protocol or an investigational new drug (IND) protocol accepted by FDA; or

(4) Prepared by the licensee for use in research in accordance with a radioactive drug research committee-approved application or an investigational new drug (IND) protocol accepted by FDA.

#### NEW SECTION

**WAC 246-240-154 Training for uptake, dilution, and excretion studies.** Except as provided in WAC 246-240-078, the licensee shall require an authorized user of unsealed radioactive material for the uses authorized under WAC 246-240-151 to be a physician who:

(1) Is certified by a medical specialty board whose certification process has been recognized by the department, the U.S. Nuclear Regulatory Commission or an agreement state and who meets the requirements of subsection (3)(b) of this section. (Specialty boards whose certification process has been recognized by the department, the U.S. NRC or an agreement state will be posted on the NRC's web page at <http://www.nrc.gov>.) To be recognized, a specialty board shall require all candidates for certification to:

(a) Meet the requirements in subsection (3)(a) of this section; and

(b) Pass an examination, administered by diplomates of the specialty board, which assesses knowledge and competence in radiation safety, radionuclide handling, and quality control; or

(2) Is an authorized user under WAC 246-240-163 or 246-240-210 or equivalent agreement state or U.S. NRC requirements; or

(3)(a) Has completed sixty hours of training and experience, including a minimum of eight hours of classroom and laboratory training, in basic radionuclide handling techniques applicable to the medical use of unsealed radioactive material for uptake, dilution, and excretion studies. The training and experience must include:

(i) Classroom and laboratory training in the following areas:

(A) Radiation physics and instrumentation;

(B) Radiation protection;

(C) Mathematics pertaining to the use and measurement of radioactivity;

(D) Chemistry of radioactive material for medical use; and

(E) Radiation biology; and

(ii) Work experience, under the supervision of an authorized user who meets the requirements in WAC 246-240-154,

246-240-163, or 246-240-210 or equivalent U.S. NRC or agreement state requirements, involving:

(A) Ordering, receiving, and unpacking radioactive materials safely and performing the related radiation surveys;

(B) Performing quality control procedures on instruments used to determine the activity of dosages and performing checks for proper operation of survey meters;

(C) Calculating, measuring, and safely preparing patient or human research subject dosages;

(D) Using administrative controls to prevent a medical event involving the use of unsealed radioactive material;

(E) Using procedures to contain spilled radioactive material safely and using proper decontamination procedures; and

(F) Administering dosages of radioactive drugs to patients or human research subjects; and

(b) Has obtained written certification, signed by a preceptor authorized user who meets the requirements in WAC 246-240-154, 246-240-163, or 246-240-210 or equivalent agreement state or U.S. NRC requirements, that the individual has satisfactorily completed the requirements in (a) of this subsection and has achieved a level of competency sufficient to function independently as an authorized user for the medical uses authorized under WAC 246-240-151.

#### NEW SECTION

**WAC 246-240-157 Use of unsealed radioactive material for imaging and localization studies for which a written directive is not required.** Except for quantities that require a written directive under WAC 246-240-060(2), a licensee may use any unsealed radioactive material prepared for medical use for imaging and localization studies that is:

(1) Obtained from a manufacturer or preparer licensed under WAC 246-235-100(1) or equivalent agreement state or U.S. NRC requirements; or

(2) Prepared by an authorized nuclear pharmacist, a physician who is an authorized user and who meets the requirements specified in WAC 246-240-163 or 246-240-210, or an individual under the supervision of either as specified in WAC 246-240-057;

(3) Obtained from and prepared by an agreement state or U.S. NRC licensee for use in research in accordance with a radioactive drug research committee-approved protocol or an investigational new drug (IND) protocol accepted by FDA; or

(4) Prepared by the licensee for use in research in accordance with a radioactive drug research committee-approved application or an investigational new drug (IND) protocol accepted by FDA.

#### NEW SECTION

**WAC 246-240-160 Permissible molybdenum-99 concentration.** (1) A licensee may not administer to humans a radiopharmaceutical that contains more than 5.55 kilobecquerel of molybdenum-99 per 37 megabecquerel of technetium-99m (0.15 microcurie of molybdenum-99 per millicurie of technetium-99m).

(2) A licensee that uses molybdenum-99/technetium-99m generators for preparing a technetium-99m radiophar-

maceutical shall measure the molybdenum-99 concentration of the first eluate after receipt of a generator to demonstrate compliance with subsection (1) of this section.

(3) If a licensee is required to measure the molybdenum-99 concentration, the licensee shall retain a record of each measurement in accordance with WAC 246-240-587.

#### NEW SECTION

**WAC 246-240-163 Training for imaging and localization studies.** Except as provided in WAC 246-240-078, the licensee shall require an authorized user of unsealed radioactive material for the uses authorized under WAC 246-240-157 to be a physician who:

(1) Is certified by a medical specialty board whose certification process has been recognized by the department, the U.S. Nuclear Regulatory Commission or an agreement state and who meets the requirements in subsection (3)(b) of this section. (Specialty boards whose certification process has been recognized by the commission or an agreement state will be posted on the U.S. NRC's web page at <http://www.nrc.gov>.) To be recognized, a specialty board shall require all candidates for certification to:

(a) Satisfy the requirements in subsection (3)(a) of this section; and

(b) Pass an examination, administered by diplomates of the specialty board, which assesses knowledge and competence in radiation safety, radionuclide handling, and quality control;

(2) Is an authorized user under WAC 246-240-210 or equivalent agreement state or U.S. NRC requirements prior to October 24, 2005; or

(3)(a) Has completed seven hundred hours of training and experience, including a minimum of eighty hours of classroom and laboratory training, in basic radionuclide handling techniques applicable to the medical use of unsealed radioactive material for imaging and localization studies. The training and experience must include, at a minimum:

(i) Classroom and laboratory training in the following areas:

(A) Radiation physics and instrumentation;

(B) Radiation protection;

(C) Mathematics pertaining to the use and measurement of radioactivity;

(D) Chemistry of radioactive material for medical use;

(E) Radiation biology; and

(ii) Work experience, under the supervision of an authorized user, who meets the requirements in WAC 246-240-163 or 246-240-210 or equivalent agreement state or U.S. NRC requirements, involving:

(A) Ordering, receiving, and unpacking radioactive materials safely and performing the related radiation surveys;

(B) Performing quality control procedures on instruments used to determine the activity of dosages and performing checks for proper operation of survey meters;

(C) Calculating, measuring, and safely preparing patient or human research subject dosages;

(D) Using administrative controls to prevent a medical event involving the use of unsealed radioactive material;

(E) Using procedures to safely contain spilled radioactive material and using proper decontamination procedures;

(F) Administering dosages of radioactive drugs to patients or human research subjects; and

(G) Eluting generator systems appropriate for preparation of radioactive drugs for imaging and localization studies, measuring and testing the eluate for radionuclidic purity, and processing the eluate with reagent kits to prepare labeled radioactive drugs; and

(b) Has obtained written certification, signed by a preceptor authorized user who meets the requirements in WAC 246-240-163 or 246-240-210 or equivalent agreement state or U.S. NRC requirements, that the individual has satisfactorily completed the requirements in (a) of this subsection and has achieved a level of competency sufficient to function independently as an authorized user for the medical uses authorized under WAC 246-240-151 and 246-240-157.

#### NEW SECTION

**WAC 246-240-201 Use of unsealed radioactive material for which a written directive is required.** A licensee may use any unsealed radioactive material prepared for medical use and for which a written directive is required that is:

(1) Obtained from a manufacturer or preparer licensed under WAC 246-235-100(1) or equivalent agreement state or U.S. NRC requirements; or

(2) Prepared by an authorized nuclear pharmacist, a physician who is an authorized user and who meets the requirements specified in WAC 246-240-163 or 246-240-210, or an individual under the supervision of either as specified in WAC 246-240-057; or

(3) Obtained from and prepared by an agreement state or U.S. NRC licensee for use in research in accordance with an investigational new drug (IND) protocol accepted by FDA; or

(4) Prepared by the licensee for use in research in accordance with an investigational new drug (IND) protocol accepted by FDA.

#### NEW SECTION

**WAC 246-240-204 Safety instruction.** In addition to the requirements of WAC 246-222-030:

(1) A licensee shall provide radiation safety instruction, initially and at least annually, to personnel caring for patients or human research subjects who cannot be released under WAC 246-240-122. To satisfy this requirement, the instruction must be commensurate with the duties of the personnel and include:

(a) Patient or human research subject control;

(b) Visitor control, including:

(i) Routine visitation to hospitalized individuals in accordance with WAC 246-221-060 (1)(a); and

(ii) Visitation authorized in accordance with WAC 246-221-060(2);

(c) Contamination control;

(d) Waste control; and

(e) Notification of the radiation safety officer, or their designee, and the authorized user if the patient or the human research subject has a medical emergency or dies.

(2) A licensee shall retain a record of individuals receiving instruction in accordance with WAC 246-240-590.

#### NEW SECTION

**WAC 246-240-207 Safety precautions.** (1) For each patient or human research subject who cannot be released under WAC 246-240-122, a licensee shall:

(a) Quarter the patient or the human research subject either in:

(i) A private room with a private sanitary facility; or

(ii) A room, with a private sanitary facility, with another individual who also has received therapy with unsealed radioactive material and who also cannot be released under WAC 246-240-122;

(b) Visibly post the patient's or the human research subject's room with a "Caution—Radioactive Materials" sign.

(c) Note on the door or in the patient's or human research subject's chart where and how long visitors may stay in the patient's or the human research subject's room; and

(d) Either monitor material and items removed from the patient's or the human research subject's room to determine that their radioactivity cannot be distinguished from the natural background radiation level with a radiation detection survey instrument set on its most sensitive scale and with no interposed shielding, or handle the material and items as radioactive waste.

(2) A licensee shall notify the radiation safety officer, or their designee, and the authorized user as soon as possible if the patient or human research subject has a medical emergency or dies.

#### NEW SECTION

**WAC 246-240-210 Training for use of unsealed radioactive material for which a written directive is required.** Except as provided in WAC 246-240-078, the licensee shall require an authorized user of unsealed radioactive material for the uses authorized under WAC 246-240-201 to be a physician who:

(1) Is certified by a medical specialty board whose certification process has been recognized by the department, the U.S. Nuclear Regulatory Commission or an agreement state. (Specialty boards whose certification process has been recognized by the commission or an agreement state will be posted on the NRC's web page at <http://www.nrc.gov>.) To be recognized, a specialty board shall require all candidates for certification to:

(a) Successfully complete a residency training in a radiation therapy or nuclear medicine training program or a program in a related medical specialty that includes seven hundred hours of training and experience as described in subsection (2) of this section. Eligible training programs must be approved by the Residency Review Committee of the Accreditation Council for Graduate Medical Education or Royal College of Physicians and Surgeons of Canada or the Committee on Postgraduate Training of the American Osteopathic Association;

(b) Pass an examination, administered by diplomates of the specialty board, which tests knowledge and competence

in radiation safety, radionuclide handling, quality assurance, and clinical use of unsealed by-product material; and

(c) Obtain written certification that the individual has achieved a level of competency sufficient to function independently as an authorized user for the medical uses authorized under WAC 246-240-201. The written certification must be signed by a preceptor authorized user who meets the requirements in WAC 246-240-210 or equivalent U.S. NRC or agreement state requirements. The preceptor authorized user, who meets the requirements in WAC 246-240-210 must have experience in administering dosages in the same dosage category or categories (i.e., this section) as the individual requesting authorized user status; or

(2) Has completed seven hundred hours of training and experience, including a minimum of two hundred hours of classroom and laboratory training, in basic radionuclide handling techniques applicable to the medical use of unsealed radioactive material requiring a written directive. The training and experience must include:

(a) Classroom and laboratory training in the following areas:

(i) Radiation physics and instrumentation;

(ii) Radiation protection;

(iii) Mathematics pertaining to the use and measurement of radioactivity;

(iv) Chemistry of radioactive material for medical use; and

(v) Radiation biology; and

(b) Work experience, under the supervision of an authorized user who meets the requirements in subsection (1) or (2) of this section, or equivalent U.S. NRC or agreement state requirements. A supervising authorized user, who meets the requirements in this subsection, must also have experience in administering dosages in the same dosage category or categories (i.e., this section) as the individual requesting authorized user status. The work experience must involve:

(i) Ordering, receiving, and unpacking radioactive materials safely and performing the related radiation surveys;

(ii) Performing quality control procedures on instruments used to determine the activity of dosages and performing checks for proper operation of survey meters;

(iii) Calculating, measuring, and safely preparing patient or human research subject dosages;

(iv) Using administrative controls to prevent a medical event involving the use of unsealed radioactive material;

(v) Using procedures to contain spilled radioactive material safely and using proper decontamination procedures;

(vi) Eluting generator systems, measuring and testing the eluate for radionuclidic purity, and processing the eluate with reagent kits to prepare labeled radioactive drugs; and

(vii) Administering dosages of radioactive drugs to patients or human research subjects involving a minimum of three cases in each of the following categories for which the individual is requesting authorized user status:

(A) Oral administration of less than or equal to 1.22 gigabecquerels (33 millicuries) of sodium iodide I-131;

(B) Oral administration of greater than 1.22 gigabecquerels (33 millicuries) of sodium iodide I-131. Experience with at least three cases in this also satisfies the requirement in (b)(vii)(A) of this subsection;

(C) Parenteral administration of any beta emitter or a photon-emitting radionuclide with a photon energy less than 150 keV for which a written directive is required; and/or

(D) Parenteral administration of any other radionuclide for which a written directive is required; and

(E) Has obtained written certification that the individual has satisfactorily completed the requirements in subsection (1)(a) and (b) of this section and has achieved a level of competency sufficient to function independently as an authorized user for the medical uses authorized under WAC 246-240-201. The written certification must be signed by a preceptor authorized user who meets the requirements in this section, or equivalent U.S. NRC or agreement state requirements. The preceptor authorized user, who meets the requirements in this subsection (2), must have experience in administering dosages in the same dosage category or categories (i.e., this section) as the individual requesting authorized user status.

#### NEW SECTION

**WAC 246-240-213 Training for the oral administration of sodium iodide I-131 requiring a written directive in quantities less than or equal to 1.22 gigabecquerels (33 millicuries).** Except as provided in WAC 246-240-078, the licensee shall require an authorized user for the oral administration of sodium iodide I-131 requiring a written directive in quantities less than or equal to 1.22 gigabecquerels (33 millicuries), to be a physician who:

(1) Is certified by a medical specialty board whose certification process includes all of the requirements in subsection (3) of this section and whose certification has been recognized by the department, the U.S. Nuclear Regulatory Commission or an agreement state. (Specialty boards whose certification process has been recognized by the commission or an agreement state will be posted on the NRC's web page at <http://www.nrc.gov>); or

(2) Is an authorized user under WAC 246-240-210 for uses listed in WAC 246-240-210 or 246-240-216, or equivalent agreement state or U.S. NRC requirements; or

(3)(a) Has successfully completed eighty hours of classroom and laboratory training, applicable to the medical use of sodium iodide I-131 for procedures requiring a written directive. The training must include:

- (i) Radiation physics and instrumentation;
- (ii) Radiation protection;
- (iii) Mathematics pertaining to the use and measurement of radioactivity;
- (iv) Chemistry of radioactive material for medical use; and

(v) Radiation biology; and

(b) Has work experience, under the supervision of an authorized user who meets the requirements in WAC 246-240-210, 246-240-213, 246-240-216, or equivalent agreement state or U.S. NRC requirements. A supervising authorized user who meets the requirements in WAC 246-240-210(2), must have experience in administering dosages as specified in WAC 246-240-210. The work experience must involve:

(i) Ordering, receiving, and unpacking radioactive materials safely and performing the related radiation surveys;

(ii) Performing quality control procedures on instruments used to determine the activity of dosages and performing checks for proper operation of survey meters;

(iii) Calculating, measuring, and safely preparing patient or human research subject dosages;

(iv) Using administrative controls to prevent a medical event involving the use of radioactive material;

(v) Using procedures to contain spilled radioactive material safely and using proper decontamination procedures; and

(vi) Administering dosages to patients or human research subjects, that includes at least three cases involving the oral administration of less than or equal to 1.22 gigabecquerels (33 millicuries) of sodium iodide I-131; and

(c) Has obtained written certification that the individual has satisfactorily completed the requirements in (a) and (b) of this subsection and has achieved a level of competency sufficient to function independently as an authorized user for medical uses authorized under WAC 246-240-201. The written certification must be signed by a preceptor authorized user who meets the requirements in WAC 246-240-210, 246-240-213, 246-240-216, or equivalent agreement state or U.S. NRC requirements. A preceptor authorized user, who meets the requirement in WAC 246-240-210, must have experience in administering dosages as specified in WAC 246-240-210.

#### NEW SECTION

**WAC 246-240-216 Training for the oral administration of sodium iodide I-131 requiring a written directive in quantities greater than 1.22 gigabecquerels (33 millicuries).** Except as provided in WAC 246-240-078, the licensee shall require an authorized user for the oral administration of sodium iodide I-131 requiring a written directive in quantities greater than 1.22 gigabecquerels (33 millicuries), to be a physician who:

(1) Is certified by a medical specialty board whose certification process includes all of the requirements in subsection (3) of this section and whose certification has been recognized by the department, the U.S. NRC or an agreement state. (Specialty boards whose certification process has been recognized by the commission or an agreement state will be posted on the NRC's web page at <http://www.nrc.gov>); or

(2) Is an authorized user under WAC 246-240-210 for uses listed in WAC 246-240-210, or equivalent agreement state or U.S. NRC requirements; or

(3)(a) Has successfully completed eighty hours of classroom and laboratory training, applicable to the medical use of sodium iodide I-131 for procedures requiring a written directive. The training must include:

- (i) Radiation physics and instrumentation;
- (ii) Radiation protection;
- (iii) Mathematics pertaining to the use and measurement of radioactivity;
- (iv) Chemistry of radioactive material for medical use; and

(v) Radiation biology; and

(b) Has work experience, under the supervision of an authorized user who meets the requirements in WAC 246-240-210, 246-240-216, or equivalent agreement state or U.S. NRC requirements. A supervising authorized user, who

meets the requirements in WAC 246-240-210(2), must have experience in administering dosages as specified in WAC 246-240-210.

The work experience must involve:

- (i) Ordering, receiving, and unpacking radioactive materials safely and performing the related radiation surveys;
- (ii) Performing quality control procedures on instruments used to determine the activity of dosages and performing checks for proper operation of survey meters;
- (iii) Calculating, measuring, and safely preparing patient or human research subject dosages;
- (iv) Using administrative controls to prevent a medical event involving the use of radioactive material;
- (v) Using procedures to contain spilled radioactive material safely and using proper decontamination procedures; and
- (vi) Administering dosages to patients or human research subjects, that includes at least three cases involving the oral administration of greater than 1.22 gigabecquerels (33 millicuries) of sodium iodide I-131; and
- (c) Has obtained written certification that the individual has satisfactorily completed the requirements in (a) and (b) of this subsection and has achieved a level of competency sufficient to function independently as an authorized user for medical uses authorized under WAC 246-240-201. The written certification must be signed by a preceptor authorized user who meets the requirements in WAC 246-240-210, 246-240-216, or equivalent agreement state or U.S. NRC requirements. A preceptor authorized user, who meets the requirements in WAC 246-240-210(2), must have experience in administering dosages as specified in WAC 246-240-210.

#### NEW SECTION

**WAC 246-240-219 Training for the parenteral administration of unsealed radioactive material requiring a written directive.** Except as provided in WAC 246-240-078, the licensee shall require an authorized user for the parenteral administration requiring a written directive, to be a physician who:

- (1) Is an authorized user under WAC 246-240-210 or equivalent agreement state or U.S. NRC requirements; or
- (2) Is an authorized user under WAC 246-240-278 or 246-240-399, or equivalent agreement state or U.S. NRC requirements and who meets the requirements in subsection (4) of this section; or
- (3) Is certified by a medical specialty board whose certification process has been recognized by the U.S. NRC or an agreement state under WAC 246-240-278 or 246-240-399, and who meets the requirements in subsection (4) of this section.
- (4)(a) Has successfully completed eighty hours of classroom and laboratory training, applicable to parenteral administrations, for which a written directive is required, of any beta emitter or any photon-emitting radionuclide with a photon energy less than 150 keV, and/or parenteral administration of any other radionuclide for which a written directive is required. The training must include:
  - (i) Radiation physics and instrumentation;
  - (ii) Radiation protection;

(iii) Mathematics pertaining to the use and measurement of radioactivity;

(iv) Chemistry of radioactive material for medical use; and

(v) Radiation biology; and

(b) Has work experience, under the supervision of an authorized user who meets the requirements in WAC 246-240-210 or 246-240-219, or equivalent agreement state or U.S. NRC requirements, in the parenteral administration, for which a written directive is required, of any beta emitter or any photon-emitting radionuclide with a photon energy less than 150 keV, and/or parenteral administration of any other radionuclide for which a written directive is required. A supervising authorized user who meets the requirements in WAC 246-240-210 or 246-240-460 must have experience in administering dosages as specified in WAC 246-240-210 (2)(b)(vii)(D) and/or (E). The work experience must involve:

(i) Ordering, receiving, and unpacking radioactive materials safely, and performing the related radiation surveys;

(ii) Performing quality control procedures on instruments used to determine the activity of dosages, and performing checks for proper operation of survey meters;

(iii) Calculating, measuring, and safely preparing patient or human research subject dosages;

(iv) Using administrative controls to prevent a medical event involving the use of unsealed radioactive material;

(v) Using procedures to contain spilled radioactive material safely, and using proper decontamination procedures; and

(vi) Administering dosages to patients or human research subjects, that include at least three cases involving the parenteral administration, for which a written directive is required, of any beta emitter or any photon-emitting radionuclide with a photon energy less than 150 keV and/or at least three cases involving the parenteral administration of any other radionuclide, for which a written directive is required; and

(5) Has obtained written certification that the individual has satisfactorily completed the requirements in subsection (2) or (3) of this section, and has achieved a level of competency sufficient to function independently as an authorized user for the parenteral administration of unsealed radioactive material requiring a written directive. The written certification must be signed by a preceptor authorized user who meets the requirements in WAC 246-240-210, 246-240-219, or equivalent agreement state or U.S. NRC requirements. A preceptor authorized user, who meets the requirements in WAC 246-240-210 or 246-240-219, must have experience in administering dosages as specified in WAC 246-240-210 (2)(b)(vii)(D) and/or (E).

#### NEW SECTION

**WAC 246-240-251 Use of sources for manual brachytherapy.** A licensee shall use only brachytherapy sources for therapeutic medical uses:

(1) As approved in the sealed source and device registry; or

(2) In research in accordance with an active investigational device exemption (IDE) application accepted by the

FDA provided the requirements of WAC 246-240-066 are met.

#### NEW SECTION

**WAC 246-240-254 Surveys after source implant and removal.** (1) Immediately after implanting sources in a patient or a human research subject, the licensee shall make a survey to locate and account for all sources that have not been implanted.

(2) Immediately after removing the last temporary implant source from a patient or a human research subject, the licensee shall make a survey of the patient or the human research subject with a radiation detection survey instrument to confirm that all sources have been removed.

(3) A licensee shall retain a record of the surveys required by subsections (1) and (2) of this section in accordance with WAC 246-240-593.

#### NEW SECTION

**WAC 246-240-260 Brachytherapy source accountability.** (1) A licensee shall maintain accountability at all times for all brachytherapy sources in storage, transport, or use.

(2) As soon as possible after removing sources from a patient or a human research subject, a licensee shall return brachytherapy sources to a secure storage area.

(3) A licensee shall maintain a record of the brachytherapy source accountability in accordance with WAC 246-240-596.

#### NEW SECTION

**WAC 246-240-263 Safety instruction.** In addition to the requirements of WAC 246-222-030:

(1) The licensee shall provide radiation safety instruction, initially and at least annually, to personnel caring for patients or human research subjects who are receiving brachytherapy and cannot be released under WAC 246-240-122. To satisfy this requirement, the instruction must be commensurate with the duties of the personnel and include the:

- (a) Size and appearance of the brachytherapy sources;
- (b) Safe handling and shielding instructions;
- (c) Patient or human research subject control;
- (d) Visitor control, including both:

(i) Routine visitation of hospitalized individuals in accordance with WAC 246-221-060 (1)(a); and

(ii) Visitation authorized in accordance with WAC 246-221-060(2); and

(e) Notification of the radiation safety officer, or their designee, and an authorized user if the patient or the human research subject has a medical emergency or dies.

(2) A licensee shall retain a record of individuals receiving instruction in accordance with WAC 246-240-590.

#### NEW SECTION

**WAC 246-240-266 Safety precautions.** (1) For each patient or human research subject who is receiving brachy-

therapy and cannot be released under WAC 246-240-122, a licensee shall:

(a) Not quarter the patient or the human research subject in the same room as an individual who is not receiving brachytherapy;

(b) Visibly post the patient's or human research subject's room with a "Caution—Radioactive Materials" sign; and

(c) Note on the door or in the patient's or human research subject's chart where and how long visitors may stay in the patient's or human research subject's room.

(2) A licensee shall have applicable emergency response equipment available near each treatment room to respond to a source:

(a) Dislodged from the patient; and

(b) Lodged within the patient following removal of the source applicators.

(3) A licensee shall notify the radiation safety officer, or their designee, and an authorized user as soon as possible if the patient or human research subject has a medical emergency or dies.

#### NEW SECTION

**WAC 246-240-269 Calibration measurements of brachytherapy sources.** (1) Before the first medical use of a brachytherapy source on or after October 24, 2006, a licensee shall have:

(a) Determined the source output or activity using a dosimetry system that meets the requirements of WAC 246-240-366(1);

(b) Determined source positioning accuracy within applicators; and

(c) Used published protocols currently accepted by nationally recognized bodies to meet the requirements of (a) and (b) of this subsection.

(2) A licensee may use measurements provided by the source manufacturer or by a calibration laboratory accredited by the American Association of Physicists in Medicine that are made in accordance with subsection (1) of this section.

(3) A licensee shall mathematically correct the outputs or activities determined in subsection (1) of this section for physical decay at intervals consistent with one percent physical decay.

(4) A licensee shall retain a record of each calibration in accordance with WAC 246-240-599.

#### NEW SECTION

**WAC 246-240-272 Decay of strontium-90 sources for ophthalmic treatments.** (1) Only an authorized medical physicist shall calculate the activity of each strontium-90 source that is used to determine the treatment times for ophthalmic treatments. The decay must be based on the activity determined under WAC 246-240-269.

(2) A licensee shall retain a record of the activity of each strontium-90 source in accordance with WAC 246-240-602.

#### NEW SECTION

**WAC 246-240-275 Therapy-related computer systems.** The licensee shall perform acceptance testing on the



treatment planning system of therapy-related computer systems in accordance with published protocols accepted by nationally recognized bodies. At a minimum, the acceptance testing must include, as applicable, verification of:

- (1) The source-specific input parameters required by the dose calculation algorithm;
- (2) The accuracy of dose, dwell time, and treatment time calculations at representative points;
- (3) The accuracy of isodose plots and graphic displays; and
- (4) The accuracy of the software used to determine sealed source positions from radiographic images.

#### NEW SECTION

**WAC 246-240-278 Training for use of manual brachytherapy sources.** Except as provided in WAC 246-240-078, the licensee shall require an authorized user of a manual brachytherapy source for the uses authorized under WAC 246-240-251 to be a physician who:

(1) Is certified by a medical specialty board whose certification process has been recognized by the department, the U.S. NRC, or an agreement state. (Specialty boards whose certification process has been recognized by the commission or an agreement state will be posted on the NRC's web page at <http://www.nrc.gov>.) To be recognized, a specialty board shall require all candidates for certification to:

(a) Successfully complete a minimum of three years of residency training in a radiation oncology program approved by the Residency Review Committee of the Accreditation Council for Graduate Medical Education or Royal College of Physicians and Surgeons of Canada or the Committee on Postgraduate Training of the American Osteopathic Association;

(b) Pass an examination, administered by diplomates of the specialty board, which tests knowledge and competence in radiation safety, radionuclide handling, treatment planning, quality assurance, and clinical use of high and low dose-rate brachytherapy; and

(c) Obtain written certification, signed by a preceptor authorized user who meets the requirements in WAC 246-240-278 or equivalent U.S. NRC or agreement state requirements, that the individual has achieved a level of competency sufficient to function independently as an authorized user of manual brachytherapy sources for the medical uses authorized in WAC 246-240-251; or

(2)(a) Has completed a structured educational program in basic radionuclide handling techniques applicable to the use of manual brachytherapy sources that includes:

(i) Two hundred hours of classroom and laboratory training in the following areas:

- (A) Radiation physics and instrumentation;
- (B) Radiation protection;
- (C) Mathematics pertaining to the use and measurement of radioactivity; and
- (D) Radiation biology; and

(ii) Five hundred hours of work experience, under the supervision of an authorized user who meets the requirements in WAC 246-240-278 or equivalent agreement state or U.S. NRC requirements at a medical institution, involving:

- (A) Ordering, receiving, and unpacking radioactive materials safely and performing the related radiation surveys;
- (B) Checking survey meters for proper operation;
- (C) Preparing, implanting, and removing brachytherapy sources;
- (D) Maintaining running inventories of material on hand;
- (E) Using administrative controls to prevent a medical event involving the use of radioactive material;
- (F) Using emergency procedures to control radioactive material; and

(b) Has completed three years of supervised clinical experience in radiation oncology, under an authorized user who meets the requirements in WAC 246-240-278 or equivalent U.S. NRC or agreement state requirements, as part of a formal training program approved by the Residency Review Committee for Radiation Oncology of the Accreditation Council for Graduate Medical Education or the Royal College of Physicians and Surgeons of Canada or the Committee on Postdoctoral Training of the American Osteopathic Association. This experience may be obtained concurrently with the supervised work experience required by (a)(ii) of this subsection; and

(c) Has obtained written certification, signed by a preceptor authorized user who meets the requirements in WAC 246-240-278 or equivalent agreement state or U.S. NRC requirements, that the individual has satisfactorily completed the requirements in (a) and (b) of this subsection and has achieved a level of competency sufficient to function independently as an authorized user of manual brachytherapy sources for the medical uses authorized under WAC 246-240-251.

#### NEW SECTION

**WAC 246-240-281 Training for ophthalmic use of strontium-90.** Except as provided in WAC 246-240-078, the licensee shall require the authorized user of strontium-90 for ophthalmic radiotherapy to be a physician who:

(1) Is an authorized user under WAC 246-240-278 or equivalent agreement state or U.S. NRC requirements; or

(2)(a) Has completed twenty-four hours of classroom and laboratory training applicable to the medical use of strontium-90 for ophthalmic radiotherapy. The training must include:

- (i) Radiation physics and instrumentation;
- (ii) Radiation protection;
- (iii) Mathematics pertaining to the use and measurement of radioactivity; and

(iv) Radiation biology; and

(b) Supervised clinical training in ophthalmic radiotherapy under the supervision of an authorized user at a medical institution that includes the use of strontium-90 for the ophthalmic treatment of five individuals.

This supervised clinical training must involve:

- (i) Examination of each individual to be treated;
- (ii) Calculation of the dose to be administered;
- (iii) Administration of the dose; and
- (iv) Follow up and review of each individual's case history; and

(c) Has obtained written certification, signed by a preceptor authorized user who meets the requirements in WAC 246-240-278, 246-240-281, or equivalent agreement state or U.S. NRC requirements, that the individual has satisfactorily completed the requirements in subsections (1) and (2) of this section and has achieved a level of competency sufficient to function independently as an authorized user of strontium-90 for ophthalmic use.

#### NEW SECTION

**WAC 246-240-301 Use of sealed sources for diagnosis.** A licensee shall use only sealed sources for diagnostic medical uses as approved in the sealed source and device registry.

#### NEW SECTION

**WAC 246-240-304 Training for use of sealed sources for diagnosis.** Except as provided in WAC 246-240-078, the licensee shall require the authorized user of a diagnostic sealed source for use in a device authorized under WAC 246-240-301 to be a physician, dentist, or podiatrist who:

(1) Is certified by a specialty board whose certification process includes all of the requirements in subsections (2) and (3) of this section and whose certification has been recognized by the Department, the U.S. NRC, or an agreement state. (Specialty boards whose certification process has been recognized by the commission or an agreement state will be posted on the NRC's web page at <http://www.nrc.gov>); or

(2) Has completed eight hours of classroom and laboratory training in basic radionuclide handling techniques specifically applicable to the use of the device. The training must include:

- (a) Radiation physics and instrumentation;
- (b) Radiation protection;
- (c) Mathematics pertaining to the use and measurement of radioactivity;
- (d) Radiation biology; and

(3) Has completed training in the use of the device for the uses requested.

#### NEW SECTION

**WAC 246-240-351 Use of a sealed source in a remote afterloader unit, teletherapy unit, or gamma stereotactic radiosurgery unit.** A licensee shall use sealed sources in photon emitting remote afterloader units, teletherapy units, or gamma stereotactic radiosurgery units for therapeutic medical uses:

(1) As approved in the sealed source and device registry; or

(2) In research in accordance with an active investigational device exemption (IDE) application accepted by the FDA provided the requirements of WAC 246-240-066(1) are met.

#### NEW SECTION

**WAC 246-240-354 Surveys of patients and human research subjects treated with a remote afterloader unit.**

(1) Before releasing a patient or a human research subject from licensee control, a licensee shall survey the patient or the human research subject and the remote afterloader unit with a portable radiation detection survey instrument to confirm that the source(s) has been removed from the patient or human research subject and returned to the safe shielded position.

(2) A licensee shall retain a record of these surveys in accordance with WAC 246-240-593.

#### NEW SECTION

**WAC 246-240-357 Installation, maintenance, adjustment, and repair.** (1) Only a person specifically licensed by the department, the U.S. NRC, or an agreement state shall install, maintain, adjust, or repair a remote afterloader unit, teletherapy unit, or gamma stereotactic radiosurgery unit that involves work on the source(s) shielding, the source(s) driving unit, or other electronic or mechanical component that could expose the source(s), reduce the shielding around the source(s), or compromise the radiation safety of the unit or the source(s).

(2) Except for low dose-rate remote afterloader units, only a person specifically licensed by the department, the U.S. NRC, or an agreement state shall install, replace, relocate, or remove a sealed source or source contained in other remote afterloader units, teletherapy units, or gamma stereotactic radiosurgery units.

(3) For a low dose-rate remote afterloader unit, only a person specifically licensed by the department, the U.S. NRC, or an agreement state or an authorized medical physicist shall install, replace, relocate, or remove a sealed source(s) contained in the unit.

(4) A licensee shall retain a record of the installation, maintenance, adjustment, and repair of remote afterloader units, teletherapy units, and gamma stereotactic radiosurgery units in accordance with WAC 246-240-605.

#### NEW SECTION

**WAC 246-240-360 Safety procedures and instructions for remote afterloader units, teletherapy units, and gamma stereotactic radiosurgery units.** (1) A licensee shall:

(a) Secure the unit, the console, the console keys, and the treatment room when not in use or unattended;

(b) Permit only individuals approved by the authorized user, radiation safety officer, or authorized medical physicist to be present in the treatment room during treatment with the source(s);

(c) Prevent dual operation of more than one radiation producing device in a treatment room if applicable; and

(d) Develop, implement, and maintain written procedures for responding to an abnormal situation when the operator is unable to place the source(s) in the shielded position, or remove the patient or human research subject from the radiation field with controls from outside the treatment room. These procedures must include:

(i) Instructions for responding to equipment failures and the names of the individuals responsible for implementing corrective actions;

(ii) The process for restricting access to and posting of the treatment area to minimize the risk of inadvertent exposure; and

(iii) The names and telephone numbers of the authorized users, the authorized medical physicist, and the radiation safety officer to be contacted if the unit or console operates abnormally.

(2) A copy of the procedures required by subsection (1)(d) of this section must be physically located at the unit console.

(3) A licensee shall post instructions at the unit console to inform the operator of:

(a) The location of the procedures required by subsection (1)(d) of this section; and

(b) The names and telephone numbers of the authorized users, the authorized medical physicist, and the radiation safety officer to be contacted if the unit or console operates abnormally.

(4) A licensee shall provide instruction, initially and at least annually, to all individuals who operate the unit, as appropriate to the individual's assigned duties, in:

(a) The procedures identified in subsection (1)(d) of this section; and

(b) The operating procedures for the unit.

(5) A licensee shall ensure that operators, authorized medical physicists, and authorized users participate in drills of the emergency procedures, initially and at least annually.

(6) A licensee shall retain a record of individuals receiving instruction required by subsection (4) of this section, in accordance with WAC 246-240-590.

(7) A licensee shall retain a copy of the procedures required by subsections (1)(d) and (4)(b) of this section in accordance with WAC 246-240-608.

#### NEW SECTION

**WAC 246-240-363 Safety precautions for remote afterloader units, teletherapy units, and gamma stereotactic radiosurgery units.** (1) A licensee shall control access to the treatment room by a door at each entrance.

(2) A licensee shall equip each entrance to the treatment room with an electrical interlock system that will:

(a) Prevent the operator from initiating the treatment cycle unless each treatment room entrance door is closed;

(b) Cause the source(s) to be shielded when an entrance door is opened; and

(c) Prevent the source(s) from being exposed following an interlock interruption until all treatment room entrance doors are closed and the source(s) on-off control is reset at the console.

(3) A licensee shall require any individual entering the treatment room to assure, through the use of appropriate radiation monitors, that radiation levels have returned to ambient levels.

(4) Except for low-dose remote afterloader units, a licensee shall construct or equip each treatment room with viewing and intercom systems to permit continuous observation of the patient or the human research subject from the treatment console during irradiation.

(5) For licensed activities where sources are placed within the patient's or human research subject's body, a licensee shall only conduct treatments which allow for expedient removal of a decoupled or jammed source.

(6) In addition to the requirements specified in subsections (1) through (5) of this section, a licensee shall:

(a) For *medium dose-rate and pulsed dose-rate remote afterloader units*, require:

(i) An authorized medical physicist and either an authorized user or a physician, under the supervision of an authorized user, who has been trained in the operation and emergency response for the unit to be physically present during the initiation of all patient treatments involving the unit; and

(ii) An authorized medical physicist and either an authorized user or an individual, under the supervision of an authorized user, who has been trained to remove the source applicator(s) in the event of an emergency involving the unit, to be immediately available during continuation of all patient treatments involving the unit.

(b) For *high dose-rate remote afterloader units*, require:

(i) An authorized user and an authorized medical physicist to be physically present during the initiation of all patient treatments involving the unit; and

(ii) An authorized medical physicist and either an authorized user or a physician, under the supervision of an authorized user, who has been trained in the operation and emergency response for the unit, to be physically present during continuation of all patient treatments involving the unit.

(c) For *gamma stereotactic radiosurgery units*, require an authorized user and an authorized medical physicist to be physically present throughout all patient treatments involving the unit.

(d) Notify the radiation safety officer, or their designee, and an authorized user as soon as possible if the patient or human research subject has a medical emergency or dies.

(7) A licensee shall have applicable emergency response equipment available near each treatment room to respond to a source:

(a) Remaining in the unshielded position; or

(b) Lodged within the patient following completion of the treatment.

#### NEW SECTION

**WAC 246-240-366 Dosimetry equipment.** (1) Except for low dose-rate remote afterloader sources where the source output or activity is determined by the manufacturer, a licensee shall have a calibrated dosimetry system available for use. To satisfy this requirement, one of the following two conditions must be met:

(a) The system must have been calibrated using a system or source traceable to the National Institute of Science and Technology (NIST) and published protocols accepted by nationally recognized bodies; or by a calibration laboratory accredited by the American Association of Physicists in Medicine (AAPM). The calibration must have been performed within the previous two years and after any servicing that may have affected system calibration; or

(b) The system must have been calibrated within the previous four years. Eighteen to thirty months after that calibra-

tion, the system must have been intercompared with another dosimetry system that was calibrated within the past twenty-four months by NIST or by a calibration laboratory accredited by the AAPM. The results of the intercomparison must indicate that the calibration factor of the licensee's system had not changed by more than two percent. The licensee may not use the intercomparison result to change the calibration factor. When intercomparing dosimetry systems to be used for calibrating sealed sources for therapeutic units, the licensee shall use a comparable unit with beam attenuators or collimators, as applicable, and sources of the same radionuclide as the source used at the licensee's facility.

(2) The licensee shall have a dosimetry system available for use for spot-check output measurements, if applicable. To satisfy this requirement, the system may be compared with a system that has been calibrated in accordance with subsection (1) of this section. This comparison must have been performed within the previous year and after each servicing that may have affected system calibration. The spot-check system may be the same system used to meet the requirement in subsection (1) of this section.

(3) The licensee shall retain a record of each calibration, intercomparison, and comparison in accordance with WAC 246-240-611.

#### NEW SECTION

**WAC 246-240-369 Full calibration measurements on teletherapy units.** (1) A licensee authorized to use a teletherapy unit for medical use shall perform full calibration measurements on each teletherapy unit:

- (a) Before the first medical use of the unit; and
  - (b) Before medical use under the following conditions:
    - (i) Whenever spot-check measurements indicate that the output differs by more than five percent from the output obtained at the last full calibration corrected mathematically for radioactive decay;
    - (ii) Following replacement of the source or following reinstallation of the teletherapy unit in a new location;
    - (iii) Following any repair of the teletherapy unit that includes removal of the source or major repair of the components associated with the source exposure assembly; and
  - (c) At intervals not exceeding one year.
- (2) To satisfy the requirement of subsection (1) of this section, full calibration measurements must include determination of:
- (a) The output within  $\pm 3$  percent for the range of field sizes and for the distance or range of distances used for medical use;
  - (b) The coincidence of the radiation field and the field indicated by the light beam localizing device;
  - (c) The uniformity of the radiation field and its dependence on the orientation of the useful beam;
  - (d) Timer accuracy and linearity over the range of use;
  - (e) On-off error; and
  - (f) The accuracy of all distance measuring and localization devices in medical use.

(3) A licensee shall use the dosimetry system described in WAC 246-240-366(1) to measure the output for one set of exposure conditions. The remaining radiation measurements

required in subsection (2)(a) of this section may be made using a dosimetry system that indicates relative dose rates.

(4) A licensee shall make full calibration measurements required by subsection (1) of this section in accordance with published protocols accepted by nationally recognized bodies.

(5) A licensee shall mathematically correct the outputs determined in subsection (2)(a) of this section for physical decay for intervals not exceeding one month for cobalt-60, six months for cesium-137, or at intervals consistent with one percent decay for all other nuclides.

(6) Full calibration measurements required by subsection (1) of this section and physical decay corrections required by subsection (5) of this section must be performed by the authorized medical physicist.

(7) A licensee shall retain a record of each calibration in accordance with WAC 246-240-614.

#### NEW SECTION

**WAC 246-240-372 Full calibration measurements on remote afterloader units.** (1) A licensee authorized to use a remote afterloader unit for medical use shall perform full calibration measurements on each unit:

- (a) Before the first medical use of the unit;
- (b) Before medical use under the following conditions:
  - (i) Following replacement of the source or following reinstallation of the unit in a new location outside the facility; and
  - (ii) Following any repair of the unit that includes removal of the source or major repair of the components associated with the source exposure assembly; and
- (c) At intervals not exceeding one calendar quarter for high dose-rate, medium dose-rate, and pulsed dose-rate remote afterloader units with sources whose half-life exceeds seventy-five days; and
- (d) At intervals not exceeding one year for low dose-rate remote afterloader units.

(2) To satisfy the requirement of subsection (1) of this section, full calibration measurements must include, as applicable, determination of:

- (a) The output within  $\pm 5$  percent;
- (b) Source positioning accuracy to within  $\pm 1$  millimeter;
- (c) Source retraction with backup battery upon power failure;
- (d) Length of the source transfer tubes;
- (e) Timer accuracy and linearity over the typical range of use;
- (f) Length of the applicators; and
- (g) Function of the source transfer tubes, applicators, and transfer tube-applicator interfaces.

(3) A licensee shall use the dosimetry system described in WAC 246-240-366(1) to measure the output.

(4) A licensee shall make full calibration measurements required by subsection (1) of this section in accordance with published protocols accepted by nationally recognized bodies.

(5) In addition to the requirements for full calibrations for low dose-rate remote afterloader units in subsection (2) of this section, a licensee shall perform an autoradiograph of the

source(s) to verify inventory and source(s) arrangement at intervals not exceeding one calendar quarter.

(6) For low dose-rate remote afterloader units, a licensee may use measurements provided by the source manufacturer that are made in accordance with subsections (1) through (5) of this section.

(7) A licensee shall mathematically correct the outputs determined in subsection (2)(a) of this section for physical decay at intervals consistent with one percent physical decay.

(8) Full calibration measurements required by subsection (1) of this section and physical decay corrections required by subsection (7) of this section must be performed by the authorized medical physicist.

(9) A licensee shall retain a record of each calibration in accordance with WAC 246-240-614.

#### NEW SECTION

**WAC 246-240-375 Full calibration measurements on gamma stereotactic radiosurgery units.** (1) A licensee authorized to use a gamma stereotactic radiosurgery unit for medical use shall perform full calibration measurements on each unit:

(a) Before the first medical use of the unit;  
 (b) Before medical use under the following conditions:  
 (i) Whenever spot-check measurements indicate that the output differs by more than five percent from the output obtained at the last full calibration corrected mathematically for radioactive decay;

(ii) Following replacement of the sources or following reinstallation of the gamma stereotactic radiosurgery unit in a new location; and

(iii) Following any repair of the gamma stereotactic radiosurgery unit that includes removal of the sources or major repair of the components associated with the source assembly; and

(c) At intervals not exceeding one year, with the exception that relative helmet factors need only be determined before the first medical use of a helmet and following any damage to a helmet.

(2) To satisfy the requirement of subsection (1) of this section, full calibration measurements must include determination of:

(a) The output within  $\pm 3$  percent;  
 (b) Relative helmet factors;  
 (c) Isocenter coincidence;  
 (d) Timer accuracy and linearity over the range of use;  
 (e) On-off error;  
 (f) Trunnion centricity;  
 (g) Treatment table retraction mechanism, using backup battery power or hydraulic backups with the unit off;  
 (h) Helmet microswitches;  
 (i) Emergency timing circuits; and  
 (j) Stereotactic frames and localizing devices (trunnions).

(3) A licensee shall use the dosimetry system described in WAC 246-240-366(1) to measure the output for one set of exposure conditions. The remaining radiation measurements required in subsection (2)(a) of this section may be made using a dosimetry system that indicates relative dose rates.

(4) A licensee shall make full calibration measurements required by subsection (1) of this section in accordance with published protocols accepted by nationally recognized bodies.

(5) A licensee shall mathematically correct the outputs determined in subsection (2)(a) of this section at intervals not exceeding one month for cobalt-60 and at intervals consistent with one percent physical decay for all other radionuclides.

(6) Full calibration measurements required by subsection (1) of this section and physical decay corrections required by subsection (5) of this section must be performed by the authorized medical physicist.

(7) A licensee shall retain a record of each calibration in accordance with WAC 246-240-614.

#### NEW SECTION

**WAC 246-240-378 Periodic spot-checks for teletherapy units.** (1) A licensee authorized to use teletherapy units for medical use shall perform output spot-checks on each teletherapy unit once in each calendar month that include determination of:

(a) Timer accuracy, and timer linearity over the range of use;

(b) On-off error;

(c) The coincidence of the radiation field and the field indicated by the light beam localizing device;

(d) The accuracy of all distance measuring and localizing devices used for medical use;

(e) The output for one typical set of operating conditions measured with the dosimetry system described in WAC 246-240-366(2); and

(f) The difference between the measurement made in (e) of this subsection and the anticipated output, expressed as a percentage of the anticipated output (i.e., the value obtained at last full calibration corrected mathematically for physical decay).

(2) A licensee shall perform measurements required by subsection (1) of this section in accordance with written procedures established by the authorized medical physicist. That individual need not actually perform the spot-check measurements.

(3) A licensee shall have the authorized medical physicist review the results of each spot-check within fifteen days. The authorized medical physicist shall notify the licensee as soon as possible in writing of the results of each spot-check.

(4) A licensee authorized to use a teletherapy unit for medical use shall perform safety spot-checks of each teletherapy facility once in each calendar month and after each source installation to assure proper operation of:

(a) Electrical interlocks at each teletherapy room entrance;

(b) Electrical or mechanical stops installed for the purpose of limiting use of the primary beam of radiation (restriction of source housing angulation or elevation, carriage or stand travel and operation of the beam on-off mechanism);

(c) Source exposure indicator lights on the teletherapy unit, on the control console, and in the facility;

(d) Viewing and intercom systems;

(e) Treatment room doors from inside and outside the treatment room; and

(f) Electrically assisted treatment room doors with the teletherapy unit electrical power turned off.

(5) If the results of the checks required in subsection (4) of this section indicate the malfunction of any system, a licensee shall lock the control console in the off position and not use the unit except as may be necessary to repair, replace, or check the malfunctioning system.

(6) A licensee shall retain a record of each spot-check required by subsections (1) and (4) of this section, and a copy of the procedures required by subsection (2) of this section, in accordance with WAC 246-240-617.

#### NEW SECTION

**WAC 246-240-381 Periodic spot-checks for remote afterloader units.** (1) A licensee authorized to use a remote afterloader unit for medical use shall perform spot-checks of each remote afterloader facility and on each unit:

(a) Before the first use of a high dose-rate, medium dose-rate, or pulsed dose-rate remote afterloader unit on a given day;

(b) Before each patient treatment with a low dose-rate remote afterloader unit; and

(c) After each source installation.

(2) A licensee shall perform the measurements required by subsection (1) of this section in accordance with written procedures established by the authorized medical physicist. That individual need not actually perform the spot check measurements.

(3) A licensee shall have the authorized medical physicist review the results of each spot-check within fifteen days. The authorized medical physicist shall notify the licensee as soon as possible in writing of the results of each spot-check.

(4) To satisfy the requirements of subsection (1) of this section, spot-checks must, at a minimum, assure proper operation of:

(a) Electrical interlocks at each remote afterloader unit room entrance;

(b) Source exposure indicator lights on the remote afterloader unit, on the control console, and in the facility;

(c) Viewing and intercom systems in each high dose-rate, medium dose-rate, and pulsed dose-rate remote afterloader facility;

(d) Emergency response equipment;

(e) Radiation monitors used to indicate the source position;

(f) Timer accuracy;

(g) Clock (date and time) in the unit's computer; and

(h) Decayed source(s) activity in the unit's computer.

(5) If the results of the checks required in subsection (4) of this section indicate the malfunction of any system, a licensee shall lock the control console in the off position and not use the unit except as may be necessary to repair, replace, or check the malfunctioning system.

(6) A licensee shall retain a record of each check required by subsection (4) of this section and a copy of the procedures required by subsection (2) of this section in accordance with WAC 246-240-620.

#### NEW SECTION

**WAC 246-240-384 Periodic spot-checks for gamma stereotactic radiosurgery units.** (1) A licensee authorized to use a gamma stereotactic radiosurgery unit for medical use shall perform spot-checks of each gamma stereotactic radiosurgery facility and on each unit:

(a) Monthly;

(b) Before the first use of the unit on a given day; and

(c) After each source installation.

(2) A licensee shall:

(a) Perform the measurements required by subsection (1) of this section in accordance with written procedures established by the authorized medical physicist. That individual need not actually perform the spot check measurements.

(b) Have the authorized medical physicist review the results of each spot-check within fifteen days. The authorized medical physicist shall notify the licensee as soon as possible in writing of the results of each spot-check.

(3) To satisfy the requirements of subsection (1)(a) of this section, spot-checks must, at a minimum:

(a) Assure proper operation of:

(i) Treatment table retraction mechanism, using backup battery power or hydraulic backups with the unit off;

(ii) Helmet microswitches;

(iii) Emergency timing circuits; and

(iv) Stereotactic frames and localizing devices (trunnions).

(b) Determine:

(i) The output for one typical set of operating conditions measured with the dosimetry system described in WAC 246-240-366(2);

(ii) The difference between the measurement made in (b)(i) of this subsection and the anticipated output, expressed as a percentage of the anticipated output (i.e., the value obtained at last full calibration corrected mathematically for physical decay);

(iii) Source output against computer calculation;

(iv) Timer accuracy and linearity over the range of use;

(v) On-off error; and

(vi) Trunnion centricity.

(4) To satisfy the requirements of subsection (1)(b) and (c) of this section, spot-checks must assure proper operation of:

(a) Electrical interlocks at each gamma stereotactic radiosurgery room entrance;

(b) Source exposure indicator lights on the gamma stereotactic radiosurgery unit, on the control console, and in the facility;

(c) Viewing and intercom systems;

(d) Timer termination;

(e) Radiation monitors used to indicate room exposures; and

(f) Emergency off buttons.

(5) A licensee shall arrange for the repair of any system identified in subsection (3) of this section that is not operating properly as soon as possible.

(6) If the results of the checks required in subsection (4) of this section indicate the malfunction of any system, a licensee shall lock the control console in the off position and not

use the unit except as may be necessary to repair, replace, or check the malfunctioning system.

(7) A licensee shall retain a record of each check required by subsections (3) and (4) of this section and a copy of the procedures required by subsection (2) of this section in accordance with WAC 246-240-623.

#### NEW SECTION

**WAC 246-240-387 Additional technical requirements for mobile remote afterloader units.** (1) A licensee providing mobile remote afterloader service shall:

(a) Check survey instruments before medical use at each address of use or on each day of use, whichever is more frequent; and

(b) Account for all sources before departure from a client's address of use.

(2) In addition to the periodic spot-checks required by WAC 246-240-381, a licensee authorized to use mobile afterloaders for medical use shall perform checks on each remote afterloader unit before use at each address of use. At a minimum, checks must be made to verify the operation of:

(a) Electrical interlocks on treatment area access points;

(b) Source exposure indicator lights on the remote afterloader unit, on the control console, and in the facility;

(c) Viewing and intercom systems;

(d) Applicators, source transfer tubes, and transfer tube-applicator interfaces;

(e) Radiation monitors used to indicate room exposures;

(f) Source positioning (accuracy); and

(g) Radiation monitors used to indicate whether the source has returned to a safe shielded position.

(3) In addition to the requirements for checks in subsection (2) of this section, a licensee shall ensure overall proper operation of the remote afterloader unit by conducting a simulated cycle of treatment before use at each address of use.

(4) If the results of the checks required in subsection (2) of this section indicate the malfunction of any system, a licensee shall lock the control console in the off position and not use the unit except as may be necessary to repair, replace, or check the malfunctioning system.

(5) A licensee shall retain a record of each check required by subsection (2) of this section in accordance with WAC 246-240-626.

#### NEW SECTION

**WAC 246-240-390 Radiation surveys.** (1) In addition to the survey requirement in WAC 246-221-110(1), a person licensed under this chapter shall make surveys to ensure that the maximum radiation levels and average radiation levels from the surface of the main source safe with the source(s) in the shielded position do not exceed the levels stated in the sealed source and device registry.

(2) The licensee shall make the survey required by subsection (1) of this section at installation of a new source and following repairs to the source(s) shielding, the source(s) driving unit, or other electronic or mechanical component that could expose the source, reduce the shielding around the source(s), or compromise the radiation safety of the unit or the source(s).

(3) A licensee shall retain a record of the radiation surveys required by subsection (1) of this section in accordance with WAC 246-240-629.

#### NEW SECTION

**WAC 246-240-393 Five-year inspection for teletherapy and gamma stereotactic radiosurgery units.** (1) A licensee shall have each teletherapy unit and gamma stereotactic radiosurgery unit fully inspected and serviced during source replacement or at intervals not to exceed five years, whichever comes first, to assure proper functioning of the source exposure mechanism.

(2) This inspection and servicing may only be performed by persons specifically licensed to do so by the department, the U.S. NRC or an agreement state.

(3) A licensee shall keep a record of the inspection and servicing in accordance with WAC 246-240-632.

#### NEW SECTION

**WAC 246-240-396 Therapy-related computer systems.** The licensee shall perform acceptance testing on the treatment planning system of therapy-related computer systems in accordance with published protocols accepted by nationally recognized bodies. At a minimum, the acceptance testing must include, as applicable, verification of:

(1) The source-specific input parameters required by the dose calculation algorithm;

(2) The accuracy of dose, dwell time, and treatment time calculations at representative points;

(3) The accuracy of isodose plots and graphic displays;

(4) The accuracy of the software used to determine sealed source positions from radiographic images; and

(5) The accuracy of electronic transfer of the treatment delivery parameters to the treatment delivery unit from the treatment planning system.

#### NEW SECTION

**WAC 246-240-399 Training for use of remote afterloader units, teletherapy units, and gamma stereotactic radiosurgery units.** Except as provided in WAC 246-240-078, the licensee shall require an authorized user of a sealed source for a use authorized under WAC 246-240-351 to be a physician who:

(1) Is certified by a medical specialty board whose certification process has been recognized by the department, the U.S. NRC, or an agreement state. (Specialty boards whose certification process has been recognized by the commission or an agreement state will be posted on the NRC's web page at <http://www.nrc.gov>.) To be recognized, a specialty board shall require all candidates for certification to:

(a) Successfully complete a minimum of three years of residency training in a radiation therapy program approved by the Residency Review Committee of the Accreditation Council for Graduate Medical Education or Royal College of Physicians and Surgeons of Canada or the Committee on Postgraduate Training of the American Osteopathic Association; and

(b) Pass an examination, administered by diplomates of the specialty board, which tests knowledge and competence in radiation safety, radionuclide handling, treatment planning, quality assurance, and clinical use of stereotactic radio-surgery, high and low dose-rate brachytherapy, and external beam therapy;

(2)(a) Has completed a structured educational program in basic radionuclide techniques applicable to the use of a sealed source in a therapeutic medical unit that includes:

(i) Two hundred hours of classroom and laboratory training in the following areas:

- (A) Radiation physics and instrumentation;
- (B) Radiation protection;
- (C) Mathematics pertaining to the use and measurement of radioactivity; and
- (D) Radiation biology; and

(ii) Five hundred hours of work experience, under the supervision of an authorized user who meets the requirements in WAC 246-240-399 or equivalent agreement state or U.S. NRC requirements at a medical institution, involving:

- (A) Reviewing full calibration measurements and periodic spot-checks;
- (B) Preparing treatment plans and calculating treatment doses and times;

(C) Using administrative controls to prevent a medical event involving the use of radioactive material;

(D) Implementing emergency procedures to be followed in the event of the abnormal operation of the medical unit or console;

(E) Checking and using survey meters; and

(F) Selecting the proper dose and how it is to be administered; and

(b) Has completed three years of supervised clinical experience in radiation therapy, under an authorized user who meets the requirements in WAC 246-240-399 or equivalent U.S. NRC or agreement state requirements, as part of a formal training program approved by the Residency Review Committee for Radiation Oncology of the Accreditation Council for Graduate Medical Education or Royal College of Physicians and Surgeons of Canada or the Committee on Postdoctoral Training of the American Osteopathic Association. This experience may be obtained concurrently with the supervised work experience required by (a)(ii) of this subsection; and

(c) Has obtained written certification that the individual has satisfactorily completed the requirements in (a) and (b) of this subsection and has achieved a level of competency sufficient to function independently as an authorized user of each type of therapeutic medical unit for which the individual is requesting authorized user status. The written certification must be signed by a preceptor authorized user who meets the requirements in WAC 246-240-399 or equivalent U.S. NRC or agreement state requirements for an authorized user for each type of therapeutic medical unit for which the individual is requesting authorized user status; and

(d) Has received training in device operation, safety procedures, and clinical use for the type(s) of use for which authorization is sought. This training requirement may be satisfied by satisfactory completion of a training program provided by the vendor for new users or by receiving training

supervised by an authorized user or authorized medical physicist, as appropriate, who is authorized for the type(s) of use for which the individual is seeking authorization.

#### NEW SECTION

**WAC 246-240-451 Radiation safety officer.** Except as provided in WAC 246-240-078, the licensee shall require an individual fulfilling the responsibilities of the radiation safety officer as provided in WAC 246-240-051 to be an individual who:

(1) Is certified by the:

(a) American Board of Health Physics in Comprehensive Health Physics; or

(b) American Board of Radiology; or

(c) American Board of Nuclear Medicine; or

(d) American Board of Science in Nuclear Medicine; or

(e) Board of Pharmaceutical Specialties in Nuclear Pharmacy; or

(f) American Board of Medical Physics in radiation oncology physics; or

(g) Royal College of Physicians and Surgeons of Canada in nuclear medicine; or

(h) American Osteopathic Board of Radiology; or

(i) American Osteopathic Board of Nuclear Medicine; or

(2) Has had classroom and laboratory training and experience as follows:

(a) Two hundred hours of classroom and laboratory training that includes:

(i) Radiation physics and instrumentation;

(ii) Radiation protection;

(iii) Mathematics pertaining to the use and measurement of radioactivity;

(iv) Radiation biology; and

(v) Radiopharmaceutical chemistry; and

(b) One year of full-time experience as a radiation safety technologist at a medical institution under the supervision of the individual identified as the radiation safety officer on an agreement state or U.S. Nuclear Regulatory Commission license that authorizes the medical use of radioactive material; or

(3) Is an authorized user identified on the licensee's license.

#### NEW SECTION

**WAC 246-240-454 Training for uptake, dilution, and excretion studies.** Except as provided in WAC 246-240-078, the licensee shall require the authorized user of a radiopharmaceutical in WAC 246-240-151 to be a physician who:

(1) Is certified in:

(a) Nuclear medicine by the American Board of Nuclear Medicine; or

(b) Diagnostic radiology by the American Board of Radiology; or

(c) Diagnostic radiology or radiology by the American Osteopathic Board of Radiology; or

(d) Nuclear medicine by the Royal College of Physicians and Surgeons of Canada; or

(e) American Osteopathic Board of Nuclear Medicine in nuclear medicine; or



(2) Has had classroom and laboratory training in basic radioisotope handling techniques applicable to the use of prepared radiopharmaceuticals, and supervised clinical experience as follows:

(a) Forty hours of classroom and laboratory training that includes:

(i) Radiation physics and instrumentation;  
 (ii) Radiation protection;  
 (iii) Mathematics pertaining to the use and measurement of radioactivity;

(iv) Radiation biology; and

(v) Radiopharmaceutical chemistry; and

(b) Twenty hours of supervised clinical experience under the supervision of an authorized user and that includes:

(i) Examining patients or human research subjects and reviewing their case histories to determine their suitability for radioisotope diagnosis, limitations, or contraindications;

(ii) Selecting the suitable radiopharmaceuticals and calculating and measuring the dosages;

(iii) Administering dosages to patients or human research subjects and using syringe radiation shields;

(iv) Collaborating with the authorized user in the interpretation of radioisotope test results; and

(v) Patient or human research subject follow up; or

(3) Has successfully completed a six-month training program in nuclear medicine as part of a training program that has been approved by the Accreditation Council for Graduate Medical Education and that included classroom and laboratory training, work experience, and supervised clinical experience in all the topics identified in subsection (2) of this section.

#### NEW SECTION

**WAC 246-240-457 Training for imaging and localization studies.** Except as provided in WAC 246-240-078, the licensee shall require the authorized user of a radiopharmaceutical, generator, or reagent kit in WAC 246-240-157 to be a physician who:

(1) Is certified in:

(a) Nuclear medicine by the American Board of Nuclear Medicine; or

(b) Diagnostic radiology by the American Board of Radiology; or

(c) Diagnostic radiology or radiology by the American Osteopathic Board of Radiology; or

(d) Nuclear medicine by the Royal College of Physicians and Surgeons of Canada; or

(e) American Osteopathic Board of Nuclear Medicine in nuclear medicine; or

(2) Has had classroom and laboratory training in basic radioisotope handling techniques applicable to the use of prepared radiopharmaceuticals, generators, and reagent kits, supervised work experience, and supervised clinical experience as follows:

(a) Two hundred hours of classroom and laboratory training that includes:

(i) Radiation physics and instrumentation;

(ii) Radiation protection;

(iii) Mathematics pertaining to the use and measurement of radioactivity;

(iv) Radiopharmaceutical chemistry; and

(v) Radiation biology; and

(b) Five hundred hours of supervised work experience under the supervision of an authorized user that includes:

(i) Ordering, receiving, and unpacking radioactive materials safely and performing the related radiation surveys;

(ii) Calibrating dose calibrators and diagnostic instruments and performing checks for proper operation of survey meters;

(iii) Calculating and safely preparing patient or human research subject dosages;

(iv) Using administrative controls to prevent the medical event of radioactive material;

(v) Using procedures to contain spilled radioactive material safely and using proper decontamination procedures; and

(vi) Eluting technetium-99m from generator systems, measuring and testing the eluate for molybdenum-99 and alumina contamination, and processing the eluate with reagent kits to prepare technetium-99m labeled radiopharmaceuticals; and

(c) Five hundred hours of supervised clinical experience under the supervision of an authorized user that includes:

(i) Examining patients or human research subjects and reviewing their case histories to determine their suitability for radioisotope diagnosis, limitations, or contraindications;

(ii) Selecting the suitable radiopharmaceuticals and calculating and measuring the dosages;

(iii) Administering dosages to patients or human research subjects and using syringe radiation shields;

(iv) Collaborating with the authorized user in the interpretation of radioisotope test results; and

(v) Patient or human research subject follow up; or

(3) Has successfully completed a six-month training program in nuclear medicine that has been approved by the Accreditation Council for Graduate Medical Education and that included classroom and laboratory training, work experience, and supervised clinical experience in all the topics identified in subsection (2) of this section.

#### NEW SECTION

**WAC 246-240-460 Training for therapeutic use of unsealed radioactive material.** Except as provided in WAC 246-240-078, the licensee shall require the authorized user of radiopharmaceuticals in WAC 246-240-201 to be a physician who:

(1) Is certified by:

(a) The American Board of Nuclear Medicine; or

(b) The American Board of Radiology in radiology, therapeutic radiology, or radiation oncology; or

(c) The Royal College of Physicians and Surgeons of Canada in nuclear medicine; or

(d) The American Osteopathic Board of Radiology after 1984; or

(2) Has had classroom and laboratory training in basic radioisotope handling techniques applicable to the use of therapeutic radiopharmaceuticals, and supervised clinical experience as follows:

(a) Eighty hours of classroom and laboratory training that includes:

- (i) Radiation physics and instrumentation;
- (ii) Radiation protection;
- (iii) Mathematics pertaining to the use and measurement of radioactivity; and

(iv) Radiation biology; and

(b) Supervised clinical experience under the supervision of an authorized user at a medical institution that includes:

(i) Use of iodine-131 for diagnosis of thyroid function and the treatment of hyperthyroidism or cardiac dysfunction in ten individuals; and

(ii) Use of iodine-131 for treatment of thyroid carcinoma in three individuals.

#### NEW SECTION

**WAC 246-240-463 Training for treatment of hyperthyroidism.** Except as provided in WAC 246-240-078, the licensee shall require the authorized user of only iodine-131 for the treatment of hyperthyroidism to be a physician with special experience in thyroid disease who has had classroom and laboratory training in basic radioisotope handling techniques applicable to the use of iodine-131 for treating hyperthyroidism, and supervised clinical experience as follows:

(1) Eighty hours of classroom and laboratory training that includes:

- (a) Radiation physics and instrumentation;
- (b) Radiation protection;
- (c) Mathematics pertaining to the use and measurement of radioactivity; and

(d) Radiation biology; and

(2) Supervised clinical experience under the supervision of an authorized user that includes the use of iodine-131 for diagnosis of thyroid function, and the treatment of hyperthyroidism in ten individuals.

#### NEW SECTION

**WAC 246-240-466 Training for treatment of thyroid carcinoma.** Except as provided in WAC 246-240-078, the licensee shall require the authorized user of only iodine-131 for the treatment of thyroid carcinoma to be a physician with special experience in thyroid disease who has had classroom and laboratory training in basic radioisotope handling techniques applicable to the use of iodine-131 for treating thyroid carcinoma, and supervised clinical experience as follows:

(1) Eighty hours of classroom and laboratory training that includes:

- (a) Radiation physics and instrumentation;
- (b) Radiation protection;
- (c) Mathematics pertaining to the use and measurement of radioactivity; and

(d) Radiation biology; and

(2) Supervised clinical experience under the supervision of an authorized user that includes the use of iodine-131 for the treatment of thyroid carcinoma in three individuals.

#### NEW SECTION

**WAC 246-240-469 Training for use of brachytherapy sources.** Except as provided in WAC 246-240-078 the licensee shall require the authorized user of a brachytherapy source listed in WAC 246-240-251 for therapy to be a physician who:

(1) Is certified in:

(a) Radiology, therapeutic radiology, or radiation oncology by the American Board of Radiology; or

(b) Radiation oncology by the American Osteopathic Board of Radiology; or

(c) Radiology, with specialization in radiotherapy, as a British "Fellow of the Faculty of Radiology" or "Fellow of the Royal College of Radiology"; or

(d) Therapeutic radiology by the Canadian Royal College of Physicians and Surgeons; or

(2) Is in the active practice of therapeutic radiology, has had classroom and laboratory training in radioisotope handling techniques applicable to the therapeutic use of brachytherapy sources, supervised work experience, and supervised clinical experience as follows:

(a) Two hundred hours of classroom and laboratory training that includes:

(i) Radiation physics and instrumentation;

(ii) Radiation protection;

(iii) Mathematics pertaining to the use and measurement of radioactivity; and

(iv) Radiation biology;

(b) Five hundred hours of supervised work experience under the supervision of an authorized user at a medical institution that includes:

(i) Ordering, receiving, and unpacking radioactive materials safely and performing the related radiation surveys;

(ii) Checking survey meters for proper operation;

(iii) Preparing, implanting, and removing sealed sources;

(iv) Maintaining running inventories of material on hand;

(v) Using administrative controls to prevent a medical event involving radioactive material; and

(vi) Using emergency procedures to control radioactive material; and

(c) Three years of supervised clinical experience that includes one year in a formal training program approved by the Residency Review Committee for Radiology of the Accreditation Council for Graduate Medical Education or the Committee on Postdoctoral Training of the American Osteopathic Association, and an additional two years of clinical experience in therapeutic radiology under the supervision of an authorized user at a medical institution that includes:

(i) Examining individuals and reviewing their case histories to determine their suitability for brachytherapy treatment, and any limitations or contraindications;

(ii) Selecting the proper brachytherapy sources and dose and method of administration;

(iii) Calculating the dose; and

(iv) Post-administration follow up and review of case histories in collaboration with the authorized user.

NEW SECTION

**WAC 246-240-472 Training for ophthalmic use of strontium-90.** Except as provided in WAC 246-240-078, the licensee shall require the authorized user of only strontium-90 for ophthalmic radiotherapy to be a physician who is in the active practice of therapeutic radiology or ophthalmology, and has had classroom and laboratory training in basic radioisotope handling techniques applicable to the use of strontium-90 for ophthalmic radiotherapy, and a period of supervised clinical training in ophthalmic radiotherapy as follows:

(1) Twenty-four hours of classroom and laboratory training that includes:

- (a) Radiation physics and instrumentation;
- (b) Radiation protection;
- (c) Mathematics pertaining to the use and measurement of radioactivity; and

(d) Radiation biology;

(2) Supervised clinical training in ophthalmic radiotherapy under the supervision of an authorized user at a medical institution that includes the use of strontium-90 for the ophthalmic treatment of five individuals that includes:

- (a) Examination of each individual to be treated;
- (b) Calculation of the dose to be administered;
- (c) Administration of the dose; and
- (d) Follow up and review of each individual's case history.

NEW SECTION

**WAC 246-240-475 Training for use of sealed sources for diagnosis.** Except as provided in WAC 246-240-078, the licensee shall require the authorized user of a sealed source in a device listed in WAC 246-240-301 to be a physician, dentist, or podiatrist who:

(1) Is certified in:

(a) Radiology, diagnostic radiology, therapeutic radiology, or radiation oncology by the American Board of Radiology;

(b) Nuclear medicine by the American Board of Nuclear Medicine;

(c) Diagnostic radiology or radiology by the American Osteopathic Board of Radiology; or

(d) Nuclear medicine by the Royal College of Physicians and Surgeons of Canada; or

(2) Has had eight hours of classroom and laboratory training in basic radioisotope handling techniques specifically applicable to the use of the device that includes:

(a) Radiation physics, mathematics pertaining to the use and measurement of radioactivity, and instrumentation;

(b) Radiation biology;

(c) Radiation protection; and

(d) Training in the use of the device for the uses requested.

NEW SECTION

**WAC 246-240-478 Training for use of therapeutic medical devices.** Except as provided in WAC 246-240-078, the licensee shall require the authorized user of a sealed source listed in WAC 246-240-351 to be a physician who:

(1) Is certified in:

(a) Radiology, therapeutic radiology, or radiation oncology by the American Board of Radiology; or

(b) Radiation oncology by the American Osteopathic Board of Radiology; or

(c) Radiology, with specialization in radiotherapy, as a British "Fellow of the Faculty of Radiology" or "Fellow of the Royal College of Radiology"; or

(d) Therapeutic radiology by the Canadian Royal College of Physicians and Surgeons; or

(2) Is in the active practice of therapeutic radiology, and has had classroom and laboratory training in basic radioisotope techniques applicable to the use of a sealed source in a therapeutic medical device, supervised work experience, and supervised clinical experience as follows:

(a) Two hundred hours of classroom and laboratory training that includes:

(i) Radiation physics and instrumentation;

(ii) Radiation protection;

(iii) Mathematics pertaining to the use and measurement of radioactivity; and

(iv) Radiation biology;

(b) Five hundred hours of supervised work experience under the supervision of an authorized user at a medical institution that includes:

(i) Review of the full calibration measurements and periodic spot-checks;

(ii) Preparing treatment plans and calculating treatment times;

(iii) Using administrative controls to prevent medical events;

(iv) Implementing emergency procedures to be followed in the event of the abnormal operation of the medical device or console; and

(v) Checking and using survey meters; and

(c) Three years of supervised clinical experience that includes one year in a formal training program approved by the Residency Review Committee for Radiology of the Accreditation Council for Graduate Medical Education or the Committee on Postdoctoral Training of the American Osteopathic Association and an additional two years of clinical experience in therapeutic radiology under the supervision of an authorized user at a medical institution that includes:

(i) Examining individuals and reviewing their case histories to determine their suitability for teletherapy, remote afterloader, or gamma stereotactic radiosurgery treatment, and any limitations or contraindications;

(ii) Selecting the proper dose and how it is to be administered;

(iii) Calculating the doses and collaborating with the authorized user in the review of patients' or human research subjects' progress and consideration of the need to modify originally prescribed doses as warranted by patients' or human research subjects' reaction to radiation; and

(iv) Post-administration follow up and review of case histories.

NEW SECTION

**WAC 246-240-481 Training for authorized medical physicist.** The licensee shall require the authorized medical physicist to be an individual who:

- (1) Is certified by the American Board of Radiology in:
  - (a) Therapeutic radiological physics; or
  - (b) Roentgen ray and gamma ray physics; or
  - (c) X-ray and radium physics; or
  - (d) Radiological physics; or
- (2) Is certified by the American Board of Medical Physics in radiation oncology physics; or
- (3) Holds a master's or doctor's degree in physics, biophysics, radiological physics, or health physics, and has completed one year of full-time training in therapeutic radiological physics and an additional year of full-time work experience under the supervision of a medical physicist at a medical institution that includes the tasks listed in WAC 246-240-113, 246-240-369, 246-240-372, 246-240-375, 246-240-378, 246-240-381, 246-240-384, and 246-240-390, as applicable.

NEW SECTION

**WAC 246-240-484 Training for an authorized nuclear pharmacist.** The licensee shall require the authorized nuclear pharmacist to be a pharmacist who:

- (1) Has current board certification as a nuclear pharmacist by the Board of Pharmaceutical Specialties; or
- (2)(a) Has completed seven hundred hours in a structured educational program consisting of both:
  - (i) Didactic training in the following areas:
    - (A) Radiation physics and instrumentation;
    - (B) Radiation protection;
    - (C) Mathematics pertaining to the use and measurement of radioactivity;
    - (D) Chemistry of radioactive material for medical use; and
    - (E) Radiation biology; and
  - (ii) Supervised experience in a nuclear pharmacy involving the following:
    - (A) Shipping, receiving, and performing related radiation surveys;
    - (B) Using and performing checks for proper operation of dose calibrators, survey meters, and, if appropriate, instruments used to measure alpha- or beta-emitting radionuclides;
    - (C) Calculating, assaying, and safely preparing dosages for patients or human research subjects;
    - (D) Using administrative controls to avoid mistakes in the administration of radioactive material;
    - (E) Using procedures to prevent or minimize contamination and using proper decontamination procedures; and
- (b) Has obtained written certification, signed by a preceptor authorized nuclear pharmacist, that the above training has been satisfactorily completed and that the individual has achieved a level of competency sufficient to independently operate a nuclear pharmacy.

NEW SECTION

**WAC 246-240-487 Training for experienced nuclear pharmacists.** A licensee may apply for and must receive a

license amendment identifying an experienced nuclear pharmacist as an authorized nuclear pharmacist before it allows this individual to work as an authorized nuclear pharmacist. A pharmacist who has completed a structured educational program as specified in WAC 246-240-484 before December 2, 1994, and who is working in a nuclear pharmacy would qualify as an experienced nuclear pharmacist. An experienced nuclear pharmacist need not comply with the requirements for a preceptor statement (WAC 246-240-484) and recentness of training (WAC 246-240-081) to qualify as an authorized nuclear pharmacist.

NEW SECTION

**WAC 246-240-501 Other medical uses of radioactive material or radiation from radioactive material.** A licensee may use radioactive material or a radiation source approved for medical use which is not specifically addressed in WAC 246-240-251 through 246-240-399 (inclusive) if:

- (1) The applicant or licensee has submitted the information required by WAC 246-240-019; and
- (2) The applicant or licensee has received written approval from the department in a license or license amendment and uses the material in accordance with the regulations and specific conditions the department considers necessary for the medical use of the material.

NEW SECTION

**WAC 246-240-551 Records of authority and responsibilities for radiation protection programs.** (1) A licensee shall retain a record of actions taken by the licensee's management in accordance with WAC 246-240-051(1) for five years. The record must include a summary of the actions taken and a signature of licensee management.

(2) The licensee shall retain a copy of both authority, duties, and responsibilities of the radiation safety officer as required by WAC 246-240-051(5), and a signed copy of each radiation safety officer's agreement to be responsible for implementing the radiation safety program, as required by WAC 246-240-051(2), for the duration of the license. The records must include the signature of the radiation safety officer and licensee management.

NEW SECTION

**WAC 246-240-554 Records of radiation protection program changes.** A licensee shall retain a record of each radiation protection program change made in accordance with WAC 246-240-054(1) for five years. The record must include a copy of the old and new procedures; the effective date of the change; and the signature of the licensee management that reviewed and approved the change.

NEW SECTION

**WAC 246-240-557 Records of written directives.** A licensee shall retain a copy of each written directive as required by WAC 246-240-060 for three years.

NEW SECTION

**WAC 246-240-560 Records for procedures for administrations requiring a written directive.** A licensee shall retain a copy of the procedures required by WAC 246-240-063(1) for the duration of the license.

NEW SECTION

**WAC 246-240-563 Records of calibrations of instruments used to measure the activity of unsealed radioactive material.** A licensee shall maintain a record of instrument calibrations required by WAC 246-240-101 for three years. The records must include the model and serial number of the instrument, the date of the calibration, the results of the calibration, and the name of the individual who performed the calibration.

NEW SECTION

**WAC 246-240-566 Records of radiation survey instrument calibrations.** A licensee shall maintain a record of radiation survey instrument calibrations required by WAC 246-240-104 for three years. The record must include the model and serial number of the instrument, the date of the calibration, the results of the calibration, and the name of the individual who performed the calibration.

NEW SECTION

**WAC 246-240-569 Records of dosages of unsealed radioactive material for medical use.** (1) A licensee shall maintain a record of dosage determinations required by WAC 246-240-107 for three years.

(2) The record must contain:

- (a) The radiopharmaceutical;
- (b) The patient's or human research subject's name, or identification number if one has been assigned;
- (c) The prescribed dosage, the determined dosage, or a notation that the total activity is less than 1.1 MBq (30  $\mu$ Ci);
- (d) The date and time of the dosage determination; and
- (e) The name of the individual who determined the dosage.

NEW SECTION

**WAC 246-240-572 Records of leak tests and inventory of sealed sources and brachytherapy sources.** (1) A licensee shall retain records of leak tests required by WAC 246-240-113 for three years. The records must include the model number, and serial number if one has been assigned, of each source tested; the identity of each source by radionuclide and its estimated activity; the results of the test; the date of the test; and the name of the individual who performed the test.

(2) A licensee shall retain records of the semiannual physical inventory of sealed sources and brachytherapy sources required by WAC 246-240-113 for three years. The inventory records must contain the model number of each source, and serial number if one has been assigned, the identity of each source by radionuclide and its nominal activity,

the location of each source, and the name of the individual who performed the inventory.

NEW SECTION

**WAC 246-240-575 Records of surveys for ambient radiation exposure rate.** A licensee shall retain a record of each survey required by WAC 246-240-119 for three years. The record must include the date of the survey, the results of the survey, the instrument used to make the survey, and the name of the individual who performed the survey.

NEW SECTION

**WAC 246-240-578 Records of the release of individuals containing unsealed radioactive material or implants containing radioactive material.** (1) A licensee shall retain a record of the basis for authorizing the release of an individual in accordance with WAC 246-240-122, if the total effective dose equivalent is calculated by:

- (a) Using the retained activity rather than the activity administered;
- (b) Using an occupancy factor less than 0.25 at 1 meter;
- (c) Using the biological or effective half-life; or
- (d) Considering the shielding by tissue.

(2) A licensee shall retain a record that the instructions required by WAC 246-240-122(2) were provided to a breast-feeding female if the radiation dose to the infant or child from continued breast-feeding could result in a total effective dose equivalent exceeding 5 mSv (0.5 rem).

(3) The records required by subsections (1) and (2) of this section must be retained for three years after the date of release of the individual.

NEW SECTION

**WAC 246-240-581 Records of mobile medical services.** (1) A licensee shall retain a copy of each letter that permits the use of radioactive material at a client's address, as required by WAC 246-240-125. Each letter must clearly delineate the authority and responsibility of the licensee and the client and must be retained for three years after the last provision of service.

(2) A licensee shall retain the record of each survey required by WAC 246-240-125 (1)(d) for three years. The record must include the date of the survey, the results of the survey, the instrument used to make the survey, and the name of the individual who performed the survey.

NEW SECTION

**WAC 246-240-584 Records of decay-in-storage.** A licensee shall maintain records of the disposal of licensed materials, as required by WAC 246-240-128, for three years. The record must include the date of the disposal, the survey instrument used, the background radiation level, the radiation level measured at the surface of each waste container, and the name of the individual who performed the survey.

NEW SECTION

**WAC 246-240-587 Records of molybdenum-99 concentrations.** A licensee shall maintain a record of the molybdenum-99 concentration tests required by WAC 246-240-160(2) for three years. The record must include, for each measured elution of technetium-99m, the ratio of the measures expressed as kilobecquerel of molybdenum-99 per megabecquerel of technetium-99m (or microcuries of molybdenum per millicurie of technetium), the time and date of the measurement, and the name of the individual who made the measurement.

NEW SECTION

**WAC 246-240-590 Records of safety instruction.** A licensee shall maintain a record of safety instructions required by WAC 246-240-204, 246-240-263, and 246-240-360 for three years. The record must include a list of the topics covered, the date of the instruction, the name(s) of the attendee(s), and the name(s) of the individual(s) who provided the instruction.

NEW SECTION

**WAC 246-240-593 Records of surveys after source implant and removal.** A licensee shall maintain a record of the surveys required by WAC 246-240-354 and 246-240-593 for three years. Each record must include the date and results of the survey, the survey instrument used, and the name of the individual who made the survey.

NEW SECTION

**WAC 246-240-596 Records of brachytherapy source accountability.** (1) A licensee shall maintain a record of brachytherapy source accountability required by WAC 246-240-260 for three years.

(2) For temporary implants, the record must include:

(a) The number and activity of sources removed from storage, the time and date they were removed from storage, the name of the individual who removed them from storage, and the location of use; and

(b) The number and activity of sources returned to storage, the time and date they were returned to storage, and the name of the individual who returned them to storage.

(3) For permanent implants, the record must include:

(a) The number and activity of sources removed from storage, the date they were removed from storage, and the name of the individual who removed them from storage;

(b) The number and activity of sources not implanted, the date they were returned to storage, and the name of the individual who returned them to storage; and

(c) The number and activity of sources permanently implanted in the patient or human research subject.

NEW SECTION

**WAC 246-240-599 Records of calibration measurements of brachytherapy sources.** (1) A licensee shall maintain a record of the calibrations of brachytherapy sources

required by WAC 246-240-269 for three years after the last use of the source.

(2) The record must include:

(a) The date of the calibration;

(b) The manufacturer's name, model number, and serial number for the source and the instruments used to calibrate the source;

(c) The source output or activity;

(d) The source positioning accuracy within the applicators; and

(e) The name of the individual, the source manufacturer, or the calibration laboratory that performed the calibration.

NEW SECTION

**WAC 246-240-602 Records of decay of strontium-90 sources for ophthalmic treatments.** (1) A licensee shall maintain a record of the activity of a strontium-90 source required by WAC 246-240-272 for the life of the source.

(2) The record must include:

(a) The date and initial activity of the source as determined under WAC 246-240-269; and

(b) For each decay calculation, the date and the source activity as determined under WAC 246-240-272.

NEW SECTION

**WAC 246-240-605 Records of installation, maintenance, adjustment, and repair of remote afterloader units, teletherapy units, and gamma stereotactic radiosurgery units.** A licensee shall retain a record of the installation, maintenance, adjustment, and repair of remote afterloader units, teletherapy units, and gamma stereotactic radiosurgery units as required by WAC 246-240-357 for three years. For each installation, maintenance, adjustment and repair, the record must include the date, description of the service, and name(s) of the individual(s) who performed the work.

NEW SECTION

**WAC 246-240-608 Records of safety procedures.** A licensee shall retain a copy of the procedures required by WAC 246-240-360 (1)(d) and (4)(b) until the licensee no longer possesses the remote afterloader, teletherapy unit, or gamma stereotactic radiosurgery unit.

NEW SECTION

**WAC 246-240-611 Records of dosimetry equipment used with remote afterloader units, teletherapy units, and gamma stereotactic radiosurgery units.** (1) A licensee shall retain a record of the calibration, intercomparison, and comparisons of its dosimetry equipment done in accordance with WAC 246-240-366 for the duration of the license.

(2) For each calibration, intercomparison, or comparison, the record must include:

(a) The date;

(b) The manufacturer's name, model numbers and serial numbers of the instruments that were calibrated, intercompared, or compared as required by WAC 246-240-366;

(c) The correction factor that was determined from the calibration or comparison or the apparent correction factor that was determined from an intercomparison; and

(d) The names of the individuals who performed the calibration, intercomparison, or comparison.

#### NEW SECTION

**WAC 246-240-614 Records of teletherapy, remote afterloader, and gamma stereotactic radiosurgery full calibrations.** (1) A licensee shall maintain a record of the teletherapy unit, remote afterloader unit, and gamma stereotactic radiosurgery unit full calibrations required by WAC 246-240-369, 246-240-372, and 246-240-375 for three years.

(2) The record must include:

(a) The date of the calibration;

(b) The manufacturer's name, model number, and serial number of the teletherapy, remote afterloader, and gamma stereotactic radiosurgery unit(s), the source(s), and the instruments used to calibrate the unit(s);

(c) The results and an assessment of the full calibrations;

(d) The results of the autoradiograph required for low dose-rate remote afterloader units; and

(e) The signature of the authorized medical physicist who performed the full calibration.

#### NEW SECTION

**WAC 246-240-617 Records of periodic spot-checks for teletherapy units.** (1) A licensee shall retain a record of each periodic spot-check for teletherapy units required by WAC 246-240-378 for three years.

(2) The record must include:

(a) The date of the spot-check;

(b) The manufacturer's name, model number, and serial number of the teletherapy unit, source and instrument used to measure the output of the teletherapy unit;

(c) An assessment of timer linearity and constancy;

(d) The calculated on-off error;

(e) A determination of the coincidence of the radiation field and the field indicated by the light beam localizing device;

(f) The determined accuracy of each distance measuring and localization device;

(g) The difference between the anticipated output and the measured output;

(h) Notations indicating the operability of each entrance door electrical interlock, each electrical or mechanical stop, each source exposure indicator light, and the viewing and intercom system and doors; and

(i) The name of the individual who performed the periodic spot-check and the signature of the authorized medical physicist who reviewed the record of the spot-check.

(3) A licensee shall retain a copy of the procedures required by WAC 246-240-378(2) until the licensee no longer possesses the teletherapy unit.

#### NEW SECTION

**WAC 246-240-620 Records of periodic spot-checks for remote afterloader units.** (1) A licensee shall retain a

record of each spot-check for remote afterloader units required by WAC 246-240-381 for three years.

(2) The record must include, as applicable:

(a) The date of the spot-check;

(b) The manufacturer's name, model number, and serial number for the remote afterloader unit and source;

(c) An assessment of timer accuracy;

(d) Notations indicating the operability of each entrance door electrical interlock, radiation monitors, source exposure indicator lights, viewing and intercom systems, and clock and decayed source activity in the unit's computer; and

(e) The name of the individual who performed the periodic spot-check and the signature of the authorized medical physicist who reviewed the record of the spot-check.

(3) A licensee shall retain a copy of the procedures required by WAC 246-240-381(2) until the licensee no longer possesses the remote afterloader unit.

#### NEW SECTION

**WAC 246-240-623 Records of periodic spot-checks for gamma stereotactic radiosurgery units.** (1) A licensee shall retain a record of each spot-check for gamma stereotactic radiosurgery units required by WAC 246-240-384 for three years.

(2) The record must include:

(a) The date of the spot-check;

(b) The manufacturer's name, model number, and serial number for the gamma stereotactic radiosurgery unit and the instrument used to measure the output of the unit;

(c) An assessment of timer linearity and accuracy;

(d) The calculated on-off error;

(e) A determination of trunnion centricity;

(f) The difference between the anticipated output and the measured output;

(g) An assessment of source output against computer calculations;

(h) Notations indicating the operability of radiation monitors, helmet microswitches, emergency timing circuits, emergency off buttons, electrical interlocks, source exposure indicator lights, viewing and intercom systems, timer termination, treatment table retraction mechanism, and stereotactic frames and localizing devices (trunnions); and

(i) The name of the individual who performed the periodic spot-check and the signature of the authorized medical physicist who reviewed the record of the spot-check.

(3) A licensee shall retain a copy of the procedures required by WAC 246-240-384(2) until the licensee no longer possesses the gamma stereotactic radiosurgery unit.

#### NEW SECTION

**WAC 246-240-626 Records of additional technical requirements for mobile remote afterloader units.** (1) A licensee shall retain a record of each check for mobile remote afterloader units required by WAC 246-240-387 for three years.

(2) The record must include:

(a) The date of the check;

(b) The manufacturer's name, model number, and serial number of the remote afterloader unit;

(c) Notations accounting for all sources before the licensee departs from a facility;

(d) Notations indicating the operability of each entrance door electrical interlock, radiation monitors, source exposure indicator lights, viewing and intercom system, applicators, source transfer tubes, and transfer tube applicator interfaces, and source positioning accuracy; and

(e) The signature of the individual who performed the check.

#### NEW SECTION

**WAC 246-240-629 Records of surveys of therapeutic treatment units.** (1) A licensee shall maintain a record of radiation surveys of treatment units made in accordance with WAC 246-240-390 for the duration of use of the unit.

(2) The record must include:

(a) The date of the measurements;

(b) The manufacturer's name, model number and serial number of the treatment unit, source, and instrument used to measure radiation levels;

(c) Each dose rate measured around the source while the unit is in the off position and the average of all measurements; and

(d) The signature of the individual who performed the test.

#### NEW SECTION

**WAC 246-240-632 Records of five-year inspection for teletherapy and gamma stereotactic radiosurgery units.** (1) A licensee shall maintain a record of the five-year inspections for teletherapy and gamma stereotactic radiosurgery units required by WAC 246-240-393 for the duration of use of the unit.

(2) The record must contain:

(a) The inspector's radioactive materials license number;

(b) The date of inspection;

(c) The manufacturer's name and model number and serial number of both the treatment unit and source;

(d) A list of components inspected and serviced, and the type of service; and

(e) The signature of the inspector.

#### NEW SECTION

**WAC 246-240-651 Report and notification of a medical event.** (1) A licensee shall report any event, except for an event that results from patient intervention, in which the administration of radioactive material or radiation from radioactive material results in:

(a) A dose that differs from the prescribed dose or dose that would have resulted from the prescribed dosage by more than 0.05 Sv (5 rem) effective dose equivalent, 0.5 Sv (50 rem) to an organ or tissue, or 0.5 Sv (50 rem) shallow dose equivalent to the skin; and

(i) The total dose delivered differs from the prescribed dose by twenty percent or more;

(ii) The total dosage delivered differs from the prescribed dosage by twenty percent or more or falls outside the prescribed dosage range; or

(iii) The fractionated dose delivered differs from the prescribed dose, for a single fraction, by fifty percent or more.

(b) A dose that exceeds 0.05 Sv (5 rem) effective dose equivalent, 0.5 Sv (50 rem) to an organ or tissue, or 0.5 Sv (50 rem) shallow dose equivalent to the skin from any of the following:

(i) An administration of a wrong radioactive drug containing radioactive material;

(ii) An administration of a radioactive drug containing radioactive material by the wrong route of administration;

(iii) An administration of a dose or dosage to the wrong individual or human research subject;

(iv) An administration of a dose or dosage delivered by the wrong mode of treatment; or

(v) A leaking sealed source.

(c) A dose to the skin or an organ or tissue other than the treatment site that exceeds by 0.5 Sv (50 rem) to an organ or tissue and fifty percent or more of the dose expected from the administration defined in the written directive (excluding, for permanent implants, seeds that were implanted in the correct site but migrated outside the treatment site).

(2) A licensee shall report any event resulting from intervention of a patient or human research subject in which the administration of radioactive material or radiation from radioactive material results or will result in unintended permanent functional damage to an organ or a physiological system, as determined by a physician.

(3) The licensee shall notify by telephone (360-236-3300) the department no later than the next calendar day after discovery of the medical event.

(4) By an appropriate method listed in WAC 246-221-250, the licensee shall submit a written report to the department at P.O. Box 47827, Olympia WA 98504-7827 within fifteen days after discovery of the medical event.

(a) The written report must include:

(i) The licensee's name;

(ii) The name of the prescribing physician;

(iii) A brief description of the event;

(iv) Why the event occurred;

(v) The effect, if any, on the individual(s) who received the administration;

(vi) What actions, if any, have been taken or are planned to prevent recurrence; and

(vii) Certification that the licensee notified the individual (or the individual's responsible relative or guardian), and if not, why not.

(b) The report may not contain the individual's name or any other information that could lead to identification of the individual.

(5) The licensee shall provide notification of the event to the referring physician and also notify the individual who is the subject of the medical event no later than twenty-four hours after its discovery, unless the referring physician personally informs the licensee either that they will inform the individual or that, based on medical judgment, telling the individual would be harmful. The licensee is not required to notify the individual without first consulting the referring physician. If the referring physician or the affected individual cannot be reached within twenty-four hours, the licensee shall notify the individual as soon as possible thereafter. The



licensee may not delay any appropriate medical care for the individual, including any necessary remedial care as a result of the medical event, because of any delay in notification. To meet the requirements of this section, the notification of the individual who is the subject of the medical event may be made instead to that individual's responsible relative or guardian. If a verbal notification is made, the licensee shall inform the individual, or appropriate responsible relative or guardian, that a written description of the event can be obtained from the licensee upon request. The licensee shall provide a written description if requested.

(6) Aside from the notification requirement, nothing in this section affects any rights or duties of licensees and physicians in relation to each other, to individuals affected by the medical event, or to that individual's responsible relatives or guardians.

(7) A licensee shall:

(a) Annotate a copy of the report provided to the department with the:

(i) Name of the individual who is the subject of the event; and

(ii) Social Security number or other identification number, if one has been assigned, of the individual who is the subject of the event; and

(b) Provide a copy of the annotated report to the referring physician, if other than the licensee, no later than fifteen days after the discovery of the event.

#### NEW SECTION

**WAC 246-240-654 Report and notification of a dose to an embryo/fetus or a nursing child.** (1) A licensee shall report to the department at P.O. Box 47827, Olympia WA 98504-7827, (phone 360-236-3300), any dose to an embryo/fetus that is greater than 50 mSv (5 rem) dose equivalent that is a result of an administration of radioactive material or radiation from radioactive material to a pregnant individual unless the dose to the embryo/fetus was specifically approved, in advance, by the authorized user.

(2) A licensee shall report any dose to a nursing child that is a result of an administration of radioactive material to a breast-feeding individual that:

(a) Is greater than 50 mSv (5 rem) total effective dose equivalent; or

(b) Has resulted in unintended permanent functional damage to an organ or a physiological system of the child, as determined by a physician.

(3) The licensee shall notify by telephone the department no later than the next calendar day after discovery of a dose to the embryo/fetus or nursing child that requires a report in subsection (1) or (2) of this section.

(4) By an appropriate method listed in WAC 246-221-250, the licensee shall submit a written report to the department within fifteen days after discovery of a dose to the embryo/fetus or nursing child that requires a report in subsection (1) or (2) of this section.

(a) The written report must include:

(i) The licensee's name;

(ii) The name of the prescribing physician;

(iii) A brief description of the event;

(iv) Why the event occurred;

(v) The effect, if any, on the embryo/fetus or the nursing child;

(vi) What actions, if any, have been taken or are planned to prevent recurrence; and

(vii) Certification that the licensee notified the pregnant individual or mother (or the mother's or child's responsible relative or guardian), and if not, why not.

(b) The report must not contain the individual's or child's name or any other information that could lead to identification of the individual or child.

(5) The licensee shall provide notification of the event to the referring physician and also notify the pregnant individual or mother, both hereafter referred to as the mother, no later than twenty-four hours after discovery of an event that would require reporting under subsection (1) or (2) of this section, unless the referring physician personally informs the licensee either that they will inform the mother or that, based on medical judgment, telling the mother would be harmful. The licensee is not required to notify the mother without first consulting with the referring physician. If the referring physician or mother cannot be reached within twenty-four hours, the licensee shall make the appropriate notifications as soon as possible thereafter. The licensee may not delay any appropriate medical care for the embryo/fetus or for the nursing child, including any necessary remedial care as a result of the event, because of any delay in notification. To meet the requirements of this subsection, the notification may be made to the mother's or child's responsible relative or guardian instead of the mother. If a verbal notification is made, the licensee shall inform the mother, or the mother's or child's responsible relative or guardian, that a written description of the event can be obtained from the licensee upon request. The licensee shall provide a written description if requested.

(6) A licensee shall:

(a) Annotate a copy of the report provided to the department with the:

(i) Name of the pregnant individual or the nursing child who is the subject of the event; and

(ii) Social Security number or other identification number, if one has been assigned, of the pregnant individual or the nursing child who is the subject of the event; and

(b) Provide a copy of the annotated report to the referring physician, if other than the licensee, no later than fifteen days after the discovery of the event.

#### NEW SECTION

**WAC 246-240-657 Report of a leaking source.** A licensee shall file a report within five days if a leak test required by WAC 246-240-113 reveals the presence of 185 Bq (0.005  $\mu$ Ci) or more of removable contamination. The report must be filed with the department, and sent to the department at P.O. Box 47827, Olympia WA 98504-7827, (phone 360-236-3300). The written report must include the model number and serial number if assigned, of the leaking source; the radionuclide and its estimated activity; the results of the test; the date of the test; and the action taken.

REPEALER

The following sections of the Washington Administrative Code are repealed:

WAC 246-240-015	Policy and procedures for therapy administration.
WAC 246-240-020	Interstitial, intracavitary and superficial applications.
WAC 246-240-030	Teletherapy.
WAC 246-240-040	Special requirements for teletherapy licensees.
WAC 246-240-050	Notifications, records, and reports of therapy misadministrations.

**WSR 05-24-116**  
**PROPOSED RULES**  
**STATE BOARD OF HEALTH**

[Filed December 7, 2005, 9:29 a.m.]

Original Notice.

Preproposal statement of inquiry was filed as WSR 05-16-050.

Title of Rule and Other Identifying Information: Food worker cards, WAC 246-217-015 Applicability and 246-217-025 Training topics.

Hearing Location(s): AmeriTel Inn, 4520 Martin Way East, Olympia, WA 98516, on January 11, 2006, at 1:30 p.m.

Date of Intended Adoption: January 11, 2006.

Submit Written Comments to: David Gifford, 111 Israel Road, Tumwater, WA 98501-7824, e-mail dave.gifford@doh.wa.gov, fax (360) 236-2257, by January 6, 2006.

Assistance for Persons with Disabilities: Contact David Gifford by January 3, 2006, TTY (800) 833-6388.

Purpose of the Proposal and Its Anticipated Effects, Including Any Changes in Existing Rules: Chapter 69.06 RCW authorizes the State Board of Health (SBOH) to issue food worker cards to all food workers in the state. During the 2005 legislative session, SHB 1591 amended chapter 69.06 RCW by conditionally exempting employees of adult family homes. These food workers will now be allowed to receive equivalent food safety training through other sources.

In addition, the SBOH has received requests to update the food worker training to include information about food allergies. There is a significant percentage of people who are allergic to one or more food items. Simple steps can be taken to prevent unnecessary serious, and sometimes fatal, reactions. The proposal requires a brief discussion or materials on food allergies to be included in all food worker card training.

Reasons Supporting Proposal: The adult family home worker amendment updates the rule to comply with statutory changes. The addition of food allergy awareness to the list of topics to be presented to food workers is reasonable due to the percentage of people with food allergies and the role food

workers can play to protect the allergic public from foods they need to avoid.

Statutory Authority for Adoption: Chapter 69.06 RCW.  
 Statute Being Implemented: Chapter 69.06 RCW.

Rule is not necessitated by federal law, federal or state court decision.

Name of Proponent: State Board of Health, governmental.

Name of Agency Personnel Responsible for Drafting, Implementation and Enforcement: David Gifford, 111 Israel Road, Tumwater, (360) 236-3074.

No small business economic impact statement has been prepared under chapter 19.85 RCW. The Department of Health and the State Board of Health have determined the proposed rule does not impose costs on businesses under RCW 19.85.030. Therefore, no small business economic impact statement is necessary.

A cost-benefit analysis is required under RCW 34.05.328. A preliminary cost-benefit analysis may be obtained by contacting David Gifford, 111 Israel Road, Tumwater, WA 98501-7824, phone (360) 236-3074, fax (360) 236-2257, e-mail dave.gifford@doh.wa.gov.

December 6, 2005

Craig McLaughlin

Executive Director

AMENDATORY SECTION (Amending WSR 99-13-019, filed 6/7/99, effective 7/8/99)

**WAC 246-217-015 Applicability.** (1) All food service workers must obtain a food worker card within fourteen calendar days from the beginning of employment at a food service establishment, except as provided in subsection (4) of this section.

(2) In the case of temporary food service establishments, at a minimum the operator or person in charge each shift or during hours of operation (~~shall~~) must have a valid food worker card obtained prior to the event.

(3) Employers at any food service establishment (permanent or temporary) must provide information or training regarding pertinent safe food handling practices to food service workers prior to beginning food handling duties if the worker does not hold a valid food worker card. Documentation that the information or training has been provided to the individual must be kept on file by the employer and be available for inspection by the health officer at all times.

(4) A food service worker in an adult family home, as defined in RCW 70.128.010, is exempt from possessing a food worker card, if the worker:

(a) Began working in an adult family home after June 30, 2005, has successfully completed basic or modified-basic caregiver training, and has documentation of receiving information or training regarding safe food handling practices from his or her employer prior to providing food handling or service for clients of the adult family home; or

(b) Held a valid food worker card prior to June 30, 2005, and obtained 0.5 hours of continuing education in food handling safety per year since June 30, 2005.

AMENDATORY SECTION (Amending WSR 02-22-079, filed 11/5/02, effective 1/1/03)

**WAC 246-217-025 Issuance of food worker cards— Fees.** (1) In order to qualify for issuance of an initial or renewal food worker card, an applicant must demonstrate his/her knowledge of safe food handling practices by satisfactorily completing an examination conducted by the local health officer or designee.

(2) Each applicant for a food worker card must pay a fee in the amount of ten dollars. The fee shall be used by the jurisdictional health department or designee to defray the costs of food worker training and education, administration of the program, and testing of applicants. Photographic identification may be required at the time of application.

(3) The local health officer or designee (~~shall~~) must furnish to the applicant a copy of the latest edition of the "Food and Beverage Service Workers' Manual" or similar publication, as prepared or approved by the department.

(4) Effective January 1, 2000, prior to conducting the examination of the applicant(s), the health officer (or designee) (~~shall~~) must provide at least thirty minutes of instruction, including both audio and visual presentations. Instruction content shall include topics related to safe food preparation, storage and service. At a minimum, topics (~~shall~~) must include: Food borne illness overview; basic bacteriology as it relates to food borne illness; proper cooking, hot holding, cold holding and cooling of potentially hazardous foods; cross-contamination prevention; and proper (~~hand washing~~) handwashing techniques. Instruction content must also include the topic of food allergy awareness that is presented and/or distributed to each applicant.

(5) The food worker card examination will be uniform statewide and will be prepared by and/or approved by the department; except that jurisdictional health departments may include additional questions to address local health concerns. The examination will cover topics identified in subsection (4) of this section, except food allergy awareness, as required instruction topics. An exam must be approved by the department prior to its use. To pass the examination the applicant must answer at least eighty percent of the questions correctly.

(6) Upon payment of the required fee and the applicant's satisfactory completion of the examination, the applicant will receive the food worker card.

(7) A copy of the card or the applicable information (~~shall~~) must be kept on file at the jurisdictional health department.

(8) Copies of food worker cards for all employed food service workers (~~shall~~) must be kept on file by the employer or kept by the employee on his or her person and open for inspection at all times by authorized public health officials.

(9) All food worker cards (~~shall~~) must be issued and signed by the local health officer. The local health officer may contract with persons to provide the required training or testing within his/her jurisdiction. The contracts (~~shall~~) must include test security provisions so that test questions, scoring keys, and other examination data are exempt from public disclosure to the same extent as records maintained by state or local government agencies.

(10) The health officer or designee (~~shall~~) must make test accommodations in accordance with the Americans with Disabilities Act for those requesting such accommodations.

## WSR 05-24-120

### PROPOSED RULES

### UTILITIES AND TRANSPORTATION COMMISSION

[Filed December 7, 2005, 9:38 a.m.]

Original Notice.

Preproposal statement of inquiry was filed as WSR 05-17-128.

Title of Rule and Other Identifying Information: WAC 480-62-400, 480-62-405, 480-62-410, 480-62-415 and 480-62-420, relating to grade crossing protective fund grant program (GCPF). This rule making has been assigned WUTC Docket No. TR-051060.

Hearing Location(s): Commission Hearing Room 206, 2nd Floor, Chandler Plaza Building, 1300 South Evergreen Park Drive S.W., on January 25, 2006, at 9:30 a.m.

Date of Intended Adoption: January 25, 2006.

Submit Written Comments to: Carole J. Washburn, Secretary, P.O. Box 47250, Olympia, WA 98504, e-mail records@wutc.wa.gov, fax (360) 586-1150, by December 28, 2005. Please include Docket No. TR-051060 in your communications.

Assistance for Persons with Disabilities: Contact Mary DeYoung by Monday, January 23, 2006, TTY (360) 586-8203 or (360) 664-1133.

Purpose of the Proposal and Its Anticipated Effects, Including Any Changes in Existing Rules: In 2003, the legislature enacted statutory changes to improve the effectiveness of the GCPF program, to improve safety on and around railroads, and to encourage participation by railroads and road authorities. The proposed WUTC rules would be adopted to establish in rules the process for awarding grants through the GCPF program.

Reasons Supporting Proposal: The proposed rules to chapter 480-62 WAC will provide for a fair and open process for the review of applications for grants for a broad range of railroad safety improvements. The rules will support the statutory goals of increased public safety by encouraging diversity and openness.

Statutory Authority for Adoption: RCW 80.01.040, 81.04.160, and 81.53.281.

Rule is not necessitated by federal law, federal or state court decision.

Name of Proponent: Washington Utilities and Transportation Commission, governmental.

Name of Agency Personnel Responsible for Drafting: Vicki Elliott, Assistant Director, Transportation Safety, 1300 South Evergreen Park Drive S.W., Olympia, WA 98504, (360) 664-1100; Implementation and Enforcement: Carole J. Washburn, Executive Secretary, 1300 South Evergreen Park Drive S.W., Olympia, WA 98504, (360) 664-1174.

No small business economic impact statement has been prepared under chapter 19.85 RCW. Because there will not

be any increase in costs resulting from the proposed rules, a small business economic impact statement is not required under RCW 19.85.030(1).

A cost-benefit analysis is not required under RCW 34.05.328. The commission is not an agency to which RCW 34.05.328 applies. The proposed rules are not significant legislative rules of the sort referenced in RCW 34.05.328(5).

December 7, 2005

David W. Danner  
for Carole J. Washburn  
Executive Secretary

**PART 4: ((ADOPTION BY REFERENCE)) GRADE CROSSING PROTECTIVE FUND**

NEW SECTION

**WAC 480-62-400 Purpose.** (1) As authorized by chapter 81.53 RCW, this chapter prescribes the manner in which a public, private or nonprofit entity may apply to the commission for grants from the grade crossing protective fund, and to prescribe a program for the award of such grants.

(2) Grade crossing protective fund grants are to fund projects that:

- (a) Reduce accident frequency and severity at either public and private railroad crossings; or
- (b) Reduce pedestrian, trespassing, and motorist injuries and deaths on railroad rights of way at places other than crossings.

NEW SECTION

**WAC 480-62-405 Applications.** (1) Any public, private or nonprofit entity may submit an application to the commission for a grant from the grade crossing protective fund. The commission will consider applications that propose projects that are within one of the following categories:

(a) **Grade crossing signals or other warning devices at public crossings.** This category includes safety improvement projects at public crossings under RCW 81.53.261 and 81.53.295.

(b) **Trespass prevention and pedestrian and motorist safety at locations other than crossings.** This category includes, but is not limited to, fencing or other physical barriers; warning devices; channeling devices; public information efforts; and enforcement-related activities.

(c) **Private crossing safety improvements.** This category includes, but is not limited to, crossing closures or consolidations; signals or warning devices; nighttime and off-hours locked gates; and making existing warning devices more noticeable.

(d) **Miscellaneous safety projects.** This category includes other projects within the scope of WAC 480-62-400(2) to foster creative and effective ideas and to address newly discovered problems. Such projects might include, but are not limited to, roadway improvements at or approaching grade crossings; mitigation of problems created by crossing closures; and removal of sight obstructions to signals or trains for the traveling public.

(2) An applicant may at any time submit an application on a form provided by the commission for a grant to pay for costs of public grade crossing signals or other warning devices as described in subsection (1)(a) of this section. The commission will evaluate and act on such applications as they are received.

(3) An applicant may at any time submit an application for a grant to pay for projects falling within the categories described in subsection (1)(b), (c), and (d) of this section. When funds are available for disbursement, the commission will issue a call for grant applications with a deadline by which applications must be submitted for competitive consideration. The commission will evaluate and act on all pending applications, deciding whether each application should be granted, in whole or in part; whether the application should be retained for further consideration if funds become available; or whether the application should be denied. Applications that have not been denied may remain active until the next ensuing call for grant applications is issued, not to exceed two years from the date of the application, or such shorter time as the commission may specify.

(4) Applicants for projects described in subsection (1)(b), (c), and (d) of this section must submit grant applications on a form provided by the commission that requires applicants to provide the following information:

- (a) A detailed summary of the hazard to be addressed, including location, accident history, and the identities of the relevant railroad company and local agency (local government that has jurisdiction over the issue and/or territory involved);
- (b) A summary of the project and how its implementation will mitigate or eliminate the hazard;
- (c) Cost estimates;
- (d) An estimated timeline for project completion;
- (e) A description of how the project's success can be measured;
- (f) A summary of efforts to coordinate with the railroad and/or local government, and the results of those efforts; and
- (g) Such other information as the commission may require.

NEW SECTION

**WAC 480-62-410 Funding for project categories.** The commission may set aside a specific amount for the category that includes public grade crossing signals and other warning devices. It may designate a portion of the total available funds for each of the other project categories. The commission may limit the amount of funding per project for each project category. The commission may also award a grant that pays a portion of a larger safety project.

NEW SECTION

**WAC 480-62-415 Evaluation and award process.** (1) The commission will evaluate each petition for a project involving grade crossing signals or other warning devices at a public crossing when it is filed. The commission will evaluate projects in other categories after the deadline specified in a call for grant applications. When evaluating projects, the commission may perform diagnostic reviews at the site of

proposed projects and may inquire about possible revisions to improve the proposal. If the applicant modifies the grant application in response to commission inquiries, the commission will consider the application in its modified form.

(2) The commission will consider grant applications at regularly scheduled open meetings. Any interested person may speak at the open meeting regarding the grant applications.

(a) The commission will award a grant for a project involving grade crossing signals or other warning devices at a public crossing if funds are available and the commission determines that the public safety requires the project. The commission will consider the severity of the hazard addressed by the project and the safety benefits expected to be achieved.

(b) The commission will award grants to projects in other categories that, in the commission's judgment, will achieve the greatest gains in safety relative to their cost. The commission will consider the relative severity of the hazard being addressed in each application, the safety benefits expected to be achieved by the proposed projects, the costs of implementing each project, and whether the applicant coordinated with and sought approval from the relevant local agency and railroad. The commission may also consider geographic diversity. The commission may condition an award on an amendment of the application regarding the requested level of funding, the suggested time limit for completion of the grant project, and any other proposed term or condition.

#### NEW SECTION

**WAC 480-62-420 Grant documents, timelines and fund transfers.** (1) As a condition of every grant award, award recipient must sign an agreement provided by the commission specifying the terms of the grant.

(2) If it appears that an award recipient is not meeting the timelines specified in the application, commission order, or agreement, the commission may set specific project milestones and deadlines for meeting them. The commission may withdraw the award if the award recipient does not achieve a milestone on time.

(3) When an award recipient completes a project, it must submit its request to the commission for disbursement of grant funds on a form provided by the commission.

(4) The commission will verify that the project is complete and meets all terms and conditions of the application, order, and agreement. When the commission confirms that the project has been completed consistent with the application, order, and agreement, the commission will disburse grant funds to the award recipient.

#### **PART 5: ADOPTION BY REFERENCE**

**WSR 05-24-128**  
**PROPOSED RULES**  
**DEPARTMENT OF PERSONNEL**

[Filed December 7, 2005, 11:20 a.m.]

Original Notice.

Exempt from preproposal statement of inquiry under RCW 34.05.310(4).

Title of Rule and Other Identifying Information: WAC 357-46-135 What causes an individual's name to be removed from a layoff list?, 357-46-140 What is the notice requirement when an individual's name has been removed from an internal or statewide layoff list?, 357-46-145 To whom and by when must an individual request a review of the removal from an internal or statewide layoff list?, 357-16-157 Is an eligible's name removed from applicant and/or candidate pools when he/she is appointed to a position?, 357-16-160 How must an employer notify an applicant or candidate who has been removed from an applicant or candidate pool?, 357-16-170 Can an applicant or candidate request a review of his/her examination results or the removal of his/her name from an applicant or candidate pool?, 357-16-175 To whom and by when must an applicant or candidate request a review of the results of an examination or removal from an applicant or candidate pool?, 357-16-177 What procedure must an employer use to review an applicant's or candidate's examination results or the removal of his/her name from an applicant or candidate pool under the provisions of WAC 357-16-170?, and 357-49-010 For what actions may an individual request a director's review?

Hearing Location(s): Department of Personnel, Classroom #4, 600 South Franklin, Olympia, WA, on January 12, 2006, at 10:00 a.m.

Date of Intended Adoption: January 12, 2006.

Submit Written Comments to: Sandi Stewart, Department of Personnel, P.O. Box 47500, fax (360) 586-4694, by January 6, 2006. FOR DOP TRACKING PURPOSES PLEASE NOTE ON SUBMITTED COMMENTS "FORMAL COMMENT."

Assistance for Persons with Disabilities: Contact Department of Personnel by January 6, 2006, TTY (360) 753-4107 or (360) 586-8260.

Purpose of the Proposal and Its Anticipated Effects, Including Any Changes in Existing Rules: These modifications and new rule remove the requirement to notify an individual who has been removed from layoff lists because of an appointment, eliminates an individual's right to request a review of a removal from a layoff list (when the removal is for a specific reason), requires an individual who is requesting a review of a removal for good and sufficient reason to submit the request to the employer, clarifies that an eligible's name is removed from the applicant pool for a class they have been appointed to and all lower classes in the same class series, and removes an individual's right to request a review of examination results.

Statutory Authority for Adoption: Chapter 41.06 RCW.  
Statute Being Implemented: RCW 41.06.150.

Rule is not necessitated by federal law, federal or state court decision.

Agency Comments or Recommendations, if any, as to Statutory Language, Implementation, Enforcement, and Fiscal Matters: These modifications and new rule are necessary to clarify when an individual will be removed from a layoff list and when the individual will have the right to appeal a removal and/or examination results.

Name of Proponent: Department of Personnel, governmental.

Name of Agency Personnel Responsible for Drafting: Sandi Stewart, 521 Capitol Way South, Olympia, WA, (360) 664-6324; Implementation and Enforcement: Department of Personnel.

No small business economic impact statement has been prepared under chapter 19.85 RCW. Not required.

A cost-benefit analysis is not required under RCW 34.05.328.

December 6, 2005  
M. P. Sellars  
for Eva N. Santos  
Director

AMENDATORY SECTION (Amending WSR 04-18-114, filed 9/1/04, effective 7/1/05)

**WAC 357-46-135 What causes an individual's name to be removed from a layoff list?** (1) An individual's name **must** be removed from an internal layoff list or statewide layoff list at the request of the individual or upon an employee's retirement, resignation, expiration of eligibility or dismissal from the employer.

(2) An individual's name **may** be removed from the internal and/or statewide layoff list for a class when:

(a) The individual is appointed to a position in the class. The individual may also be removed from the internal and/or statewide layoff list for any classes with a lower salary range maximum in that class series/occupational category.

(b) The individual is appointed to a position in a class with a higher salary range maximum in a different class series/occupational category.

~~((b))~~ (c) The individual has been certified from the layoff list and waives consideration for a position in the class three times.

~~((e))~~ (d) The employer or the department determines good and sufficient reason exists.

**Reviser's note:** The typographical errors in the above section occurred in the copy filed by the agency and appear in the Register pursuant to the requirements of RCW 34.08.040.

**Reviser's note:** RCW 34.05.395 requires the use of underlining and deletion marks to indicate amendments to existing rules. The rule published above varies from its predecessor in certain respects not indicated by the use of these markings.

AMENDATORY SECTION (Amending WSR 05-01-184, filed 12/21/04, effective 7/1/05)

**WAC 357-46-140 What is the notice requirement when an individual's name has been removed from an internal or statewide layoff list?** An individual whose name has been removed from an internal or statewide layoff list in accordance with WAC 357-46-135 (2)(b), (2)(c), and (2)(d) must be notified in writing at the time of removal. The notification must provide the specific reason for the removal and inform the individual of the right to request a review of the removal under the provisions of WAC 357-46-145. Only individuals who have had their name removed under the provisions of WAC 357-46-135 (2)(b), (2)(c), and (2)(d) have the right to request a review of the removal.

For purposes of this rule, written notice may be provided using alternative methods such as e-mail, campus mail, the

state mail service, or commercial parcel delivery in accordance with WAC 357-04-105.

AMENDATORY SECTION (Amending WSR 05-16-042, filed 7/27/05, effective 9/1/05)

**WAC 357-46-145 To whom and by when must an individual request a review of the removal from an internal or statewide layoff list?** ~~(1) ((If the employer is responsible for maintaining the layoff list, requests for review of removal from a layoff list must be made to the employer. If the individual is not in agreement with the results of the employer's review, he/she may request a director's review of the removal. If the department is responsible for maintaining the layoff list, requests for review of removal from a layoff list must be made to the director.))~~ Requests for review of removal from a layoff list must be made to the employer when:

(a) The removal is based on the employer's determination that good and sufficient reason exists under the provisions of WAC 357-46-135 (2)(d); or

(b) The employer is responsible for maintaining the layoff list and removed the individual for a reason listed in WAC 357-46-135 (2)(b) or (2)(c).

If the individual is not in agreement with the results of the employer's review, he/she may request a director's review of the removal.

(2) Requests for review of removal from a layoff list must be made to the director when:

(a) The removal is based on the department's determination that good and sufficient reason exists under the provisions of WAC 357-46-135 (2)(d);

(b) The department is responsible for maintaining the layoff list and removed the individual for a reason listed in WAC 357-46-135 (2)(b) or (2)(c); or

(c) The individual is not in agreement with the results of the employer's review of the removal.

(3) The request for a review must be received at the employer's office within twenty (20) calendar days or the director's office within ~~((twenty (20)))~~ thirty (30) calendar days following notice of the action for which a review is requested.

NEW SECTION

**WAC 357-16-157 Is an eligible's name removed from applicant and/or candidates pools when he/she is appointed to a position?** An eligible's name is removed from the applicant and/or candidate pool for the class to which he/she is appointed and all lower classes in the same class series/occupational category.

AMENDATORY SECTION (Amending WSR 05-01-200, filed 12/21/04, effective 7/1/05)

**WAC 357-16-160 ~~((How must an employer notify an applicant or candidate who has been removed from an applicant or candidate pool?))~~ Must an applicant or candidate who has been removed for good and sufficient reason per WAC 357-16-155 be notified of the removal? ~~((An))~~ When an applicant or candidate is removed from an**

applicant or candidate pool for good and sufficient reason per WAC 357-16-155, the employer or the department must notify ~~((an))~~ the applicant or candidate ~~((who has been removed from an applicant or candidate pool))~~ at the time of the removal. The notice must be in writing and specify the reason for the removal. The notice must explain the right to request a review of the removal under the provisions of WAC 357-16-170, 357-16-175 and 357-16-180. For purposes of this rule, written notice may be provided using alternative methods such as e-mail, campus mail, the state mail service, or commercial parcel delivery in accordance with WAC 357-04-105.

AMENDATORY SECTION (Amending WSR 05-01-187, filed 12/21/04, effective 7/1/05)

**WAC 357-16-170 Can an applicant or candidate request a review of ~~((his/her examination results or))~~ the removal of his/her name from an applicant or candidate pool?** An applicant or candidate may request a review of ~~((his/her examination results or))~~ the removal of his/her name from an applicant or candidate pool when the removal is due to good and sufficient reason under the provisions of WAC 357-16-155.

AMENDATORY SECTION (Amending WSR 05-01-187, filed 12/21/04, effective 7/1/05)

**WAC 357-16-175 To whom and by when must an applicant or candidate request a review of the ~~((results of an examination or))~~ removal from an applicant or candidate pool?** If the employer is responsible for the ~~((assessment process))~~ removal, the request((s)) for a review((s)) under the provisions of WAC 357-16-170 must be made to the employer. If the department is responsible for the ~~((assessment process))~~ removal, the request((s)) for a review((s)) under the provisions of WAC 357-16-170 must be made to the director.

The request for a review must be received at the employer's office or the director's office within twenty calendar days following notice of the ~~((action for which a review is requested))~~ removal.

AMENDATORY SECTION (Amending WSR 05-01-188, filed 12/21/04, effective 7/1/05)

**WAC 357-16-177 What procedure must an employer use to review ~~((an applicant's or candidate's examination results or))~~ the removal of ~~((his/her))~~ an applicant's or candidate's name from an applicant or candidate pool under the provisions of WAC 357-16-170?** Each employer must develop a review procedure that specifies the procedure the employer will use to review an applicant's or candidate's ~~((examination results or))~~ name removal from a pool. The procedure must minimally specify that the review will be conducted by a representative of the employer that was not involved in the action under review.

AMENDATORY SECTION (Amending WSR 05-19-011, filed 9/8/05, effective 10/10/05)

**WAC 357-49-010 For what actions may an individual request a director's review?** (1) If the department is responsible for ~~((the assessment process))~~ the removal of an applicant's or candidate's name from a pool as specified in WAC 357-16-175, an applicant or candidate may request a director's review of ~~((his/her examination results or))~~ the removal ~~((of his/her name from an applicant or candidate pool as specified in WAC 357-16-175))~~. Director review decisions regarding the removal of an individual's name from an applicant or candidate pool ~~((or an individual's examination results))~~ are final and not subject to further review or appeal.

(2) An individual may request a director's review of the removal of his/her name from a layoff list as specified in WAC 357-46-145.

(3) An employee may request a director's review of the following:

- (a) Allocation or reallocation per WAC 357-13-080; or
- (b) Performance evaluation process or procedure per WAC 357-37-080.

(4) In addition to the subject listed in section (2) of this rule, an employee ~~((may request a director's review of an alleged))~~ who has been adversely affected by a violation of the civil service laws or rules may request a director's review within thirty calendar days of the date the employee could reasonably be expected to have knowledge of the action giving rise to a law or rule violation claim or the stated effective date, whichever is later. An employee may not request a director's review of:

- (a) Allegations arising from the development and adoption of the classification plan under the provisions of WAC 357-10-020;
- (b) An alleged violation of civil service laws or rules pertaining to layoff, except for removal of his/her name from a layoff list as provided in subsection 2 of this section; or
- (c) The actions of reduction, dismissal, suspension, demotion or separation.

(5) An individual may request the director review his/her request for remedial action per WAC 357-19-430 or 357-19-450. Requests for remedial action must be received within thirty calendar days of the date the individual could reasonably be expected to have knowledge of the action giving rise to violation of the nonpermanent appointment or temporary appointment rules.

## WSR 05-24-129

### PROPOSED RULES

### DEPARTMENT OF PERSONNEL

[Filed December 7, 2005, 11:22 a.m.]

Original Notice.

Exempt from preproposal statement of inquiry under RCW 34.05.310(4).

Title of Rule and Other Identifying Information: WAC 357-49-023 For purposes of this chapter, how must written documents be filed? and 357-49-027 What happens if the

person requesting a director's review does not submit all of the information required by WAC 357-49-015?

Hearing Location(s): Department of Personnel, Classroom #4, 600 South Franklin, Olympia, WA, on January 12, 2006, at 10:00 a.m.

Date of Intended Adoption: January 12, 2006.

Submit Written Comments to: Sandi Stewart, Department of Personnel, P.O. Box 47500, fax (360) 586-4694, by January 6, 2006. FOR DOP TRACKING PURPOSES PLEASE NOTE ON SUBMITTED COMMENTS "FORMAL COMMENT."

Assistance for Persons with Disabilities: Contact Department of Personnel by January 6, 2006, TTY (360) 753-4107 or (360) 586-8260.

Purpose of the Proposal and Its Anticipated Effects, Including Any Changes in Existing Rules: These new rules address how written documents must be filed for a director's review and what happens if the person requesting a director's review does not file all of the information required.

Statutory Authority for Adoption: Chapter 41.06 RCW.

Statute Being Implemented: RCW 41.06.150.

Rule is not necessitated by federal law, federal or state court decision.

Agency Comments or Recommendations, if any, as to Statutory Language, Implementation, Enforcement, and Fiscal Matters: These new rules are intended to stipulate how written documents must be filed with the director of the Department of Personnel when someone is requesting a director's review and what happens if the person requesting the review does not submit all of the required information.

Name of Proponent: Department of Personnel, governmental.

Name of Agency Personnel Responsible for Drafting: Sandi Stewart, 521 Capitol Way South, Olympia, WA, (360) 664-6324; Implementation and Enforcement: Department of Personnel.

No small business economic impact statement has been prepared under chapter 19.85 RCW. Not required.

A cost-benefit analysis is not required under RCW 34.05.328.

December 6, 2006 [2005]

M. P. Sellars  
for Eva N. Santos  
Director

#### NEW SECTION

**WAC 357-49-023 For purposes of this chapter, how must written documents be filed with the director? (1) Filing papers for director's review requests.** Papers that must be filed with the director for director's review requests are considered to be filed only when the papers are actually received in the director's review office in Olympia, Washington.

**(2) Filing papers for director's review requests by telephone facsimile.**

(a) Written documents filed with the director for review requests by telephone facsimile are considered received when a legible copy of the document is reproduced on the director's telephone facsimile equipment in the director's review office. If transmission begins after customary office hours, which

are 8:00 a.m. to 5:00 p.m., Monday through Friday, excluding legal holidays, the document will be deemed filed on the next business day.

(b) Any document filed with the director by telephone facsimile should be preceded by a cover page identifying the addressee; the party making the transmission, including the address, telephone and telephone facsimile number of such party; the review to which the document relates; the date of transmission; and the total number of pages included in the transmission.

(c) The party attempting to file papers by telephone facsimile bears the risk that the papers will not be timely received or legibly printed, regardless of the cause. If the telephone facsimile is not legible, it will be considered as if it had never been sent.

(d) The original of any document filed by telephone facsimile should be mailed to the director within twenty-four hours of the time that the telephone facsimile was sent.

(3) The filing of papers for director's review requests by electronic mail ("e-mail") is not authorized without the express prior approval of the director, and only under such circumstances as the director allows.

#### NEW SECTION

**WAC 357-49-027 What happens if the person requesting a director's review does not submit all the information required by WAC 357-49-015?** (1) When the director receives a request for review, the director reviews the document(s) to determine whether the information required by this section has been provided.

(2) If any of the required information is not provided with the request for review, the director instructs the person requesting the review to provide the missing information and sends a copy of the notice to all affected parties.

(3) The person requesting the review must provide the missing information as requested within twenty-one calendar days of the date the notification is mailed.

(4) When the director receives the requested information, a copy will be sent to the other affected parties.

(5) If the person requesting the review fails to comply with the requirements of this section the director may dismiss the request for review.

**WSR 05-24-130**

**PROPOSED RULES**

**DEPARTMENT OF PERSONNEL**

[Filed December 7, 2005, 11:22 a.m.]

Original Notice.

Exempt from preproposal statement of inquiry under RCW 34.05.310(4).

Title of Rule and Other Identifying Information: WAC 357-07-065 How is the department of personnel organized?

Hearing Location(s): Department of Personnel, Classroom #4, 600 South Franklin, Olympia, WA, on January 12, 2006, at 10:00 a.m.

Date of Intended Adoption: January 12, 2006.



Submit Written Comments to: Sandi Stewart, Department of Personnel, P.O. Box 47500, fax (360) 586-4694, by January 6, 2006. FOR DOP TRACKING PURPOSES PLEASE NOTE ON SUBMITTED COMMENTS "FORMAL COMMENT."

Assistance for Persons with Disabilities: Contact Department of Personnel by January 6, 2006, TTY (360) 753-4107 or (360) 586-8260.

Purpose of the Proposal and Its Anticipated Effects, Including Any Changes in Existing Rules: The modification to this rule adds the director's reviews and appeal services as part of the Department of Personnel's organization.

Statutory Authority for Adoption: Chapter 41.06 RCW.  
Statute Being Implemented: RCW 41.06.150.

Rule is not necessitated by federal law, federal or state court decision.

Agency Comments or Recommendations, if any, as to Statutory Language, Implementation, Enforcement, and Fiscal Matters: This modification recognizes director's review and appeal services as a part of the Department of Personnel's organization.

Name of Proponent: Department of Personnel, governmental.

Name of Agency Personnel Responsible for Drafting: Sandi Stewart, 521 Capitol Way South, Olympia, WA, (360) 664-6324; Implementation and Enforcement: Department of Personnel.

No small business economic impact statement has been prepared under chapter 19.85 RCW. Not required.

A cost-benefit analysis is not required under RCW 34.05.328.

December 6, 2005

M. P. Sellars  
for Eva N. Santos  
Director

AMENDATORY SECTION (Amending WSR 05-01-202, filed 12/21/04, effective 7/1/05)

**WAC 357-07-065 How is the department of personnel organized?** The staff is organized in five general areas:

(1) Personnel services which provides consultation and services related to recruitment, assessment, affirmative action, salary surveys, compensation plan administration, and classification to state agencies, institutions of higher education, and related higher education boards.

(2) Human resource development services (located at 600 South Franklin Street, Olympia, Washington) which provides consultation on human resource development activities to agencies, training which is interagency in scope, and guidelines for agency planning and evaluation of human resource development.

(3) Administrative services which provides departmental fiscal management, facilities, agency personnel services, affirmative action, client relations, and labor relations services. Within the administrative division, the employee advisory service offices are at the following locations: 3400 Capitol Boulevard, Olympia, Washington; 613 - 19th Avenue E., Suite 101, Seattle, Washington; and at Suite 604, Northtown Office Building, Spokane, Washington.

(4) Client and employee relations services which provides general human resource consulting services and organizational development services.

(5) Director's review and appeal services (located at 2828 Capitol Boulevard, Olympia, Washington) which processes and adjudicates requests for director's reviews and provides administrative support for Personnel Resources Board appeals.

~~((5))~~ (6) Human resources information services (located at Building #1, Rowesix, 4224 6th Avenue, Lacey, Washington) which administers the central personnel/payroll and insurance eligibility computer systems.

## WSR 05-24-131

### PROPOSED RULES

#### DEPARTMENT OF PERSONNEL

[Filed December 7, 2005, 11:23 a.m.]

Original Notice.

Exempt from preproposal statement of inquiry under RCW 34.05.310(4).

Title of Rule and Other Identifying Information: WAC 357-16-130 In what order are eligible candidates certified to the employing official for hiring consideration? and 357-46-100 Who administers and establishes operating procedures for the general government transition pool program?

Hearing Location(s): Department of Personnel, Classroom #4, 600 South Franklin, Olympia, WA, on January 12, 2006, at 10:00 a.m.

Date of Intended Adoption: January 12, 2006.

Submit Written Comments to: Sandi Stewart, Department of Personnel, P.O. Box 47500, fax (360) 586-4694, by January 6, 2006. FOR DOP TRACKING PURPOSES PLEASE NOTE ON SUBMITTED COMMENTS "FORMAL COMMENT."

Assistance for Persons with Disabilities: Contact Department of Personnel by January 6, 2006, TTY (360) 753-4107 or (360) 586-8260.

Purpose of the Proposal and Its Anticipated Effects, Including Any Changes in Existing Rules: These modifications will allow a general government employer to consider internal promotional candidates prior to considering candidates from the general government transition pool.

Statutory Authority for Adoption: Chapter 41.06 RCW.

Statute Being Implemented: RCW 41.06.150.

Rule is not necessitated by federal law, federal or state court decision.

Agency Comments or Recommendations, if any, as to Statutory Language, Implementation, Enforcement, and Fiscal Matters: These modifications are necessary so that a general government employer can consider internal promotional candidates prior to considering candidates from the general government transition pool.

Name of Proponent: Department of Personnel, governmental.

Name of Agency Personnel Responsible for Drafting: Sandi Stewart, 521 Capitol Way South, Olympia, WA, (360) 664-6324; Implementation and Enforcement: Department of Personnel.

No small business economic impact statement has been prepared under chapter 19.85 RCW. Not required.

A cost-benefit analysis is not required under RCW 34.05.328.

December 6, 2005

M. P. Sellars  
for Eva N. Santos  
Director

AMENDATORY SECTION (Amending WSR 05-12-083, filed 5/27/05, effective 7/1/05)

**WAC 357-16-130 In what order are eligible candidates certified to the employing official for hiring consideration?** Only eligible candidates who satisfy the competencies and other requirements of the position to be filled will be certified. The order for certifying must follow these criteria:

(1) If there are names on the employer's internal layoff list for the class, all eligible candidates on the internal layoff list are certified to the employing official. Internal promotional candidates, as defined by the employer's promotional policy, may also be certified.

(2) If there are no names on the internal layoff list, the employer:

(a) Must certify(~~(=)~~) all statewide layoff candidates who satisfy the competencies and other position requirements.

~~((= All statewide layoff candidates who satisfy the competencies and other position requirements; and))~~

~~((= For general government employers, all transition pool candidates who satisfy the competencies and other position requirements.))~~

(b) May then certify other available eligible candidates. Any preference granted to promotional candidates must be in accordance with the employer's promotional policies as required by WAC 357-16-150.

(3) General government employers must certify transition pool candidates, who satisfy the competencies and other position requirements, when a certified pool contains eligible candidates other than layoff or internal promotional candidates.

AMENDATORY SECTION (Amending WSR 05-19-005, filed 9/8/05, effective 10/10/05)

**WAC 357-46-100 Who administers and establishes operating procedures for the general government transition pool program?** The department administers the general government transition pool program. The director develops and implements appropriate operating procedures to facilitate the program. The operating procedures include the following requirements:

(1) General government employers must certify transition pool candidates when ~~((there are no internal layoff list candidates))~~ a certified pool contains eligible candidates other than layoff or internal promotional candidates.

(2) Transition pool candidates must satisfy the competency and other position requirements to be considered for a position.

**WSR 05-24-132**

**PROPOSED RULES**

**DEPARTMENT OF PERSONNEL**

[Filed December 7, 2005, 11:24 a.m.]

Original Notice.

Exempt from preproposal statement of inquiry under RCW 34.05.310(4).

Title of Rule and Other Identifying Information: WAC 357-52-015 By when must an appeal be filed and received in order to be considered timely? and 357-52-020 What information must be submitted with an appeal?

Hearing Location(s): Department of Personnel, Classroom #4, 600 South Franklin, Olympia, WA, on January 12, 2006, at 10:00 a.m.

Date of Intended Adoption: January 12, 2006.

Submit Written Comments to: Sandi Stewart, Department of Personnel, P.O. Box 47500, fax (360) 586-4694, by January 6, 2006. FOR DOP TRACKING PURPOSES PLEASE NOTE ON SUBMITTED COMMENTS "FORMAL COMMENT."

Assistance for Persons with Disabilities: Contact Department of Personnel by January 6, 2006, TTY (360) 753-4107 or (360) 586-8260.

Purpose of the Proposal and Its Anticipated Effects, Including Any Changes in Existing Rules: The modification to WAC 357-52-015 is necessary to recognize the effective date of layoff when considering when an appeal must be filed to be considered timely. The modification to WAC 357-52-020 is necessary so that when an appeal is filed, the person filing the appeal must include the effective date of the layoff with the filing.

Statutory Authority for Adoption: Chapter 41.06 RCW.

Statute Being Implemented: RCW 41.06.150.

Rule is not necessitated by federal law, federal or state court decision.

Agency Comments or Recommendations, if any, as to Statutory Language, Implementation, Enforcement, and Fiscal Matters: The modification to WAC 357-52-015 is necessary to recognize the effective date of layoff in subsection (1) of this rule. The modification to WAC 357-52-020 is necessary so that a person filing an appeal, by rule, must include the effective date of the layoff.

Name of Proponent: Department of Personnel, governmental.

Name of Agency Personnel Responsible for Drafting: Sandi Stewart, 521 Capitol Way South, Olympia, WA, (360) 664-6324; Implementation and Enforcement: Department of Personnel.

No small business economic impact statement has been prepared under chapter 19.85 RCW. Not required.

A cost-benefit analysis is not required under RCW 34.05.328.

December 6, 2005

M. P. Sellars  
for Eva N. Santos  
Director

AMENDATORY SECTION (Amending WSR 05-01-190, filed 12/21/04, effective 7/1/05)

**WAC 357-52-015 By when must an appeal be filed and received in order to be considered timely?** In order to be considered timely, an appeal must be received in writing at the office of the board within thirty calendar days after:

- (1) The effective date of the disciplinary action, layoff, or separation,
- (2) Service of the director's determination unless the rules specifically state that the director's determination is final, or
- (3) The effective date of the exemption of a position or the notice of exemption, whichever is later.

AMENDATORY SECTION (Amending WSR 05-01-190, filed 12/21/04, effective 7/1/05)

**WAC 357-52-020 What information must be submitted with the appeal?** (1) The appeal must include:

- (a) The name and address of the appellant and if represented the name, address and telephone number of the representative,
- (b) The name of the employer and the department that took the action which is being appealed,
- (c) A telephone number at which the appellant can be reached,
- (d) The job classification or position of the employee at the time of the action which is being appealed,
- (e) A short statement of the grounds or reasons for the appeal, and if applicable, the rule(s) the appellant believes has been violated,
- (f) A short statement of the relief or remedy sought by the appellant, and
- (g) A short statement of whether the appellant believes the case would or would not be appropriate for mediation.

(2) An appeal of a disciplinary action, separation, layoff, or exemption must also include the effective date of the action and the employee's appointment status at the time of the action. The appeal must include a short statement of the nature of the action being appealed or a copy of the action letter from the employer.

(3) An appeal on exception to a director's determination must also detail the specific items of the director's determination to which exception is taken and should include a copy of the director's determination.

### WSR 05-24-133

#### PROPOSED RULES

#### DEPARTMENT OF PERSONNEL

[Filed December 7, 2005, 11:25 a.m.]

Original Notice.

Exempt from preproposal statement of inquiry under RCW 34.05.310(4).

Title of Rule and Other Identifying Information: WAC 357-52-010 What actions may be appealed?

Hearing Location(s): Department of Personnel, Classroom #4, 600 South Franklin, Olympia, WA, on January 12, 2006, at 10:00 a.m.

Date of Intended Adoption: January 12, 2006.

Submit Written Comments to: Sandi Stewart, Department of Personnel, P.O. Box 47500, fax (360) 586-4694, by January 6, 2006. FOR DOP TRACKING PURPOSES PLEASE NOTE ON SUBMITTED COMMENTS "FORMAL COMMENT."

Assistance for Persons with Disabilities: Contact Department of Personnel by January 6, 2006, TTY (360) 753-4107 or (360) 586-8260.

Purpose of the Proposal and Its Anticipated Effects, Including Any Changes in Existing Rules: This modification clarifies that a Washington management service employee can appeal a layoff action.

Statutory Authority for Adoption: Chapter 41.06 RCW.  
Statute Being Implemented: RCW 41.06.150.

Rule is not necessitated by federal law, federal or state court decision.

Agency Comments or Recommendations, if any, as to Statutory Language, Implementation, Enforcement, and Fiscal Matters: This modification is necessary to clarify that a Washington management service employee can appeal a layoff action.

Name of Proponent: Department of Personnel, governmental.

Name of Agency Personnel Responsible for Drafting: Sandi Stewart, 521 Capitol Way South, Olympia, WA, (360) 664-6324; Implementation and Enforcement: Department of Personnel.

No small business economic impact statement has been prepared under chapter 19.85 RCW. Not required.

A cost-benefit analysis is not required under RCW 34.05.328.

December 6, 2005

M. P. Sellars

for Eva N. Santos

Director

AMENDATORY SECTION (Amending WSR 05-19-011, filed 9/8/05, effective 10/10/05)

**WAC 357-52-010 What actions may be appealed? (1) Within WGS, the following actions may be appealed:**

~~((1))~~ (a) Any permanent WGS employee subject to the statutory jurisdiction of the board who is dismissed, suspended, demoted, or separated or whose base salary is reduced may appeal to the board.

~~((2))~~ (b) Any employee, subject to the statutory jurisdiction of the board who is adversely affected by a violation of the state civil service law (chapter 41.06 RCW) or the rules contained in Title 357 WAC, or an employer, may appeal to the board as follows:

~~((a))~~ (i) For a violation of state civil service law or rules relating to a layoff action, excluding removal from a layoff list, the employee may appeal directly to the board.

~~((b))~~ (ii) For a violation of state civil service law or rules relating to any other subject, including removal from a layoff list, the employee or employer may appeal to the board by fil-

ing written exceptions to the director's review determination, except as provided in WAC 357-49-010(1).

~~((3))~~ (c) Through December 31, 2005, an employee in a position at the time of its allocation or reallocation or the employer may appeal to the personnel appeals board by filing written exceptions to the director's review determination in accordance with Title 358 WAC. As of January 1, 2006, an employee in a position at the time of its allocation or reallocation or the employer may appeal to the personnel resources board by filing written exceptions to the director's review determination.

~~((4))~~ (d) An employee whose position has been exempted from chapter 41.06 RCW may appeal the exemption to the board.

~~((5))~~ (e) An individual or the employer may appeal remedial action to the board by filing written exceptions to the director's review determination.

(2) Within WMS, the following actions may be appealed:

(a) Any permanent Washington management service employee who is dismissed, suspended, demoted, laid off, or separated, or whose base salary is reduced may appeal to the board. A determination of which Washington management service positions will be eliminated in a layoff action is not subject to appeal.

(b) An employee whose position has been exempted from chapter 41.06 RCW may appeal the exemption to the board.

~~((6) Any permanent Washington management service employee who is dismissed, suspended, demoted, or separated, or whose base salary is reduced may appeal to the board. A determination of which Washington management service positions will be eliminated in a reduction-in-force action is not subject to appeal.))~~

**Reviser's note:** The typographical errors in the above section occurred in the copy filed by the agency and appear in the Register pursuant to the requirements of RCW 34.08.040.

**Reviser's note:** RCW 34.05.395 requires the use of underlining and deletion marks to indicate amendments to existing rules. The rule published above varies from its predecessor in certain respects not indicated by the use of these markings.

### WSR 05-24-134

#### PROPOSED RULES

#### DEPARTMENT OF PERSONNEL

[Filed December 7, 2005, 11:26 a.m.]

Original Notice.

Exempt from preproposal statement of inquiry under RCW 34.05.310(4).

Title of Rule and Other Identifying Information: WAC 357-52-110 Who has the burden of proof at hearings?

Hearing Location(s): Department of Personnel, Classroom #4, 600 South Franklin, Olympia, WA, on January 12, 2006, at 10:00 a.m.

Date of Intended Adoption: January 12, 2006.

Submit Written Comments to: Sandi Stewart, Department of Personnel, P.O. Box 47500, fax (360) 586-4694, by January 6, 2006. FOR DOP TRACKING PURPOSES PLEASE NOTE ON SUBMITTED COMMENTS "FORMAL COMMENT."

Assistance for Persons with Disabilities: Contact Department of Personnel by January 6, 2006, TTY (360) 753-4107 or (360) 586-8260.

Purpose of the Proposal and Its Anticipated Effects, Including Any Changes in Existing Rules: This modification clarifies that the employer has the burden of proof in an appeal of a layoff action.

Statutory Authority for Adoption: Chapter 41.06 RCW. Statute Being Implemented: RCW 41.06.150.

Rule is not necessitated by federal law, federal or state court decision.

Agency Comments or Recommendations, if any, as to Statutory Language, Implementation, Enforcement, and Fiscal Matters: This modification is necessary to clarify who has the burden of proof in an appeal of a layoff action.

Name of Proponent: Department of Personnel, governmental.

Name of Agency Personnel Responsible for Drafting: Sandi Stewart, 521 Capitol Way South, Olympia, WA, (360) 664-6324; Implementation and Enforcement: Department of Personnel.

No small business economic impact statement has been prepared under chapter 19.85 RCW. Not required.

A cost-benefit analysis is not required under RCW 34.05.328.

December 6, 2005

M. P. Sellars

for Eva N. Santos

Director

AMENDATORY SECTION (Amending WSR 05-01-191, filed 12/21/04, effective 7/1/05)

**WAC 357-52-110 Who has the burden of proof at hearings?** ~~((At any hearing on appeal from a dismissal, suspension, demotion, reduction in base salary, or separation, the employer has the burden of supporting the charges upon which the action was initiated. At any other hearing, the party filing the appeal has the burden of proof.))~~

(1) At any hearing on appeal of a:

(a) Dismissal, suspension, demotion, or reduction in base salary, the employer has the burden of supporting the charges upon which the action was initiated; or

(b) Layoff or separation, the employer has the burden of supporting both the basis for the action taken and compliance with the civil service law(s) or rule(s) governing the action.

(2) At any other hearing, the party filing the appeal has the burden of proof.

### WSR 05-24-135

#### PROPOSED RULES

#### DEPARTMENT OF PERSONNEL

[Filed December 7, 2005, 11:26 a.m.]

Original Notice.

Exempt from preproposal statement of inquiry under RCW 34.05.310(4).

Title of Rule and Other Identifying Information: WAC 357-58-438 What is the impact of a layoff?

Hearing Location(s): Department of Personnel, Classroom #4, 600 South Franklin, Olympia, WA, on January 12, 2006, at 10:00 a.m.

Date of Intended Adoption: January 12, 2006.

Submit Written Comments to: Sandi Stewart, Department of Personnel, P.O. Box 47500, fax (360) 586-4694, by January 6, 2006. FOR DOP TRACKING PURPOSES PLEASE NOTE ON SUBMITTED COMMENTS "FORMAL COMMENT."

Assistance for Persons with Disabilities: Contact Department of Personnel by January 6, 2006, TTY (360) 753-4107 or (360) 586-8260.

Purpose of the Proposal and Its Anticipated Effects, Including Any Changes in Existing Rules: This new rule will establish a rule within the Washington management service chapter to define the impact of layoff.

Statutory Authority for Adoption: Chapter 41.06 RCW.  
Statute Being Implemented: RCW 41.06.150.

Rule is not necessitated by federal law, federal or state court decision.

Agency Comments or Recommendations, if any, as to Statutory Language, Implementation, Enforcement, and Fiscal Matters: The establishment of this rule is necessary to clarify that a WMS employee has the right to appeal a layoff action even if the layoff doesn't result in the employee being separate[d] from state service.

Name of Proponent: Department of Personnel, governmental.

Name of Agency Personnel Responsible for Drafting: Sandi Stewart, 521 Capitol Way South, Olympia, WA, (360) 664-6324; Implementation and Enforcement: Department of Personnel.

No small business economic impact statement has been prepared under chapter 19.85 RCW. Not required.

A cost-benefit analysis is not required under RCW 34.05.328.

December 6, 2005

M. P. Sellars

for Eva N. Santos  
Director

#### NEW SECTION

#### **WAC 357-58-438 What is the impact of a layoff?**

Layoff is an employer-initiated action taken in accordance with WAC 357-58-445 that results in:

- (1) Separation from service with an employer;
- (2) Employment in a WMS position with a lower salary standard or evaluation points or a WGS position with a lower salary range maximum;
- (3) Reduction in the work year; or
- (4) Reduction in the number of work hours.

#### **WSR 05-24-137**

#### **PROPOSED RULES**

#### **DEPARTMENT OF**

#### **FISH AND WILDLIFE**

[Filed December 7, 2005, 11:33 a.m.]

Original Notice.

Preproposal statement of inquiry was filed as WSR 05-20-110.

Title of Rule and Other Identifying Information: Oregon sport fishing license reciprocity.

Hearing Location(s): Natural Resources Building, 1111 Washington Street, Olympia, WA, on January 13-14, 2006, begins 8:00 a.m., January 13, 2006.

Date of Intended Adoption: January 13, 2006.

Submit Written Comments to: Evan Jacoby, Rules Coordinator, 600 Capitol Way, Olympia, WA 98501-1091, e-mail jacobesj@dfw.wa.gov, fax (360) 902-2155, by January 6, 2006.

Assistance for Persons with Disabilities: Contact Susan Yeager by January 10, 2006, TTY (360) 902-2207 or (360) 902-2267.

Purpose of the Proposal and Its Anticipated Effects, Including Any Changes in Existing Rules: The Oregon legislature recently enacted sport fishing license reciprocity with Washington applicable to shellfish licenses. This rule will establish shellfish license reciprocity, and continues current fin fish license reciprocity.

Reasons Supporting Proposal: Oregon legislative action.

Statutory Authority for Adoption: RCW 77.12.047.

Statute Being Implemented: RCW 77.32.410.

Rule is not necessitated by federal law, federal or state court decision.

Name of Proponent: Department of Fish and Wildlife, governmental.

Name of Agency Personnel Responsible for Drafting: Evan Jacoby, 1111 Washington Street, Olympia, (360) 902-2930; Implementation: Ron McQueen, 1111 Washington Street, Olympia, (360) 902-2204; and Enforcement: Bruce Bjork, 1111 Washington Street, Olympia, (360) 902-2373.

A small business economic impact statement has been prepared under chapter 19.85 RCW.

#### Small Business Economic Impact Statement

1. Description of the Reporting, Record-keeping, and Other Compliance Requirements of the Proposed Rule: There is no reporting or record-keeping requirement.

2. Kinds of Professional Services That a Small Business is Likely to Need in Order to Comply with Such Requirements: None.

3. Costs of Compliance for Businesses, Including Costs of Equipment, Supplies, Labor, and Increased Administrative Costs: No compliance costs.

4. Will Compliance with the Rule Cause Businesses to Lose Sales or Revenue? This rule may affect license sales. Currently, shellfish fishers who fish in the Columbia River are required to have the license for the state waters being fished. The reciprocity will allow Oregon fishers to fish in Washington waters without purchasing a Washington license. While this may marginally affect Washington

license sales, it will have a much more significant affect on Oregon license sales, as less than 5% of the crab fishing waters at the mouth of the Columbia are within Washington state.

5. Cost of Compliance for the 10% of Businesses That are the Largest Businesses Required to Comply with the Proposed Rules Using One or More of the Following as a Basis for Comparing Costs:

- a. Cost per employee;
  - b. Cost per hour of labor; or
  - c. Cost per one hundred dollars of sales.
- No cost of compliance.

6. Steps Taken by the Agency to Reduce the Costs of the Rule on Small Businesses or Reasonable Justification for Not Doing So: There are no costs.

7. A Description of How the Agency Will Involve Small Businesses in the Development of the Rule: Public participation in the Fish and Wildlife Commission rule adoption process.

8. A List of Industries That Will Be Required to Comply with the Rule: There are no industries that are required to comply with the rule.

A copy of the statement may be obtained by contacting Evan Jacoby, 600 Capitol Way North, Olympia, WA 98501-1091, phone (360) 902-2930, fax (360) 902-2155, e-mail [jacobesj@dfw.wa.gov](mailto:jacobesj@dfw.wa.gov).

A cost-benefit analysis is not required under RCW 34.05.328. These rule proposals do not affect hydraulics.

December 7, 2005

Evan Jacoby

Rules Coordinator

daily limits, possession limits, size restrictions, and sex restrictions.

## NEW SECTION

**WAC 220-55-210 Oregon license reciprocity.** (1) A person may, from a vessel or other floating device, fish for game fish, food fish, unclassified fish, and shellfish, unless otherwise prohibited, from Pacific Ocean waters within three miles of the Washington coast from Leadbetter Point to the Washington-Oregon boundary, and from the concurrent waters of the Columbia River where the river forms the boundary between Oregon and Washington if the person possesses a valid Oregon resident angling license or a valid Oregon resident shellfish license, but only if Oregon recognizes as valid a comparable Washington personal use license in Pacific Ocean waters within three miles of the Oregon coast from the Oregon-Washington boundary to Cape Falcon and the concurrent waters of the Columbia River.

(2) This reciprocity applies only to fishing from a vessel or other floating device. Fishing from the Washington shore requires a Washington personal use license.

(3) This reciprocity applies only to Oregon residents, and residents of other states must possess either a valid Washington license or a valid Oregon license to take game fish, food fish, unclassified fish, and shellfish from the waters of the respective states.

(4) Any game fish, food fish, unclassified fish, or shellfish landed into Washington must conform with current rules in effect for the point of landing including, but not limited to,